

# MEGGER Ltd

## 6172-861



## Megger MFT1501, MFT1501E, MFT1502, and MFT1502E Service Manual

**Warning: Only suitably trained and qualified persons should undertake servicing of this product after reading the section on safety precautions.**

The copyright of this document is owned by Megger Ltd. This document must not be copied or reproduced in whole or part without the prior written consent of the copyright owner.

The company reserves the right to change the specification or design without prior notice.

AVO and Megger are Registered Trade Marks of MEGGER LIMITED.

Ed. A - 30 September, 2003(Pt No 6172-861)

This document refers to instruments built with PCB's as follows:

Measurement PCB 5240-421 Ed A4/A5

Relay PCB 5240-420 Ed A6/A7

Display PCB 5240-419 Ed A4/A5/A6

## Contents

<b>CONTENTS</b> .....	<b>1</b>
<b>INTRODUCTION</b> .....	<b>6</b>
<b>SAFETY PRECAUTIONS</b> .....	<b>6</b>
<b>DISASSEMBLY AND RE-ASSEMBLY</b> .....	<b>7</b>
1. DISASSEMBLY .....	7
2. DISPLAY REMOVAL .....	7
3. ROTARY SWITCH. ....	7
4. REASSEMBLY .....	8
<b>CRITICAL COMPONENTS</b> .....	<b>9</b>
HIGH INTEGRITY COMPONENTS.....	9
OVERLOAD PROTECTION COMPONENTS.....	9
<b>MFT SERIES CIRCUIT DESCRIPTION</b> .....	<b>10</b>
OVERVIEW .....	10
CIRCUIT ORGANIZATION .....	10
PRE-TEST .....	11
<b>SECTION 1</b> .....	<b>13</b>
1. POWER SUPPLIES .....	13
1.1 Battery .....	14
1.2 Battery Check circuit .....	14
1.3 Power on/off circuit.....	14
1.4 0V Rails .....	15
1.5 +5V Supply .....	15
1.6 -5V Supply.....	15
1.7 +18V Supply.....	15
1.8 -18V Supply .....	16
1.9 Power Supply Self-check .....	16
2. MICROCONTROLLER SYSTEM .....	16
2.1 Microcontroller.....	16
2.2 Reset Circuit.....	17
2.3 NMI Circuit.....	17
3. DISPLAY, DISPLAY CONTROLLER & BACKLIGHT .....	17
3.1 Display and Display Controller.....	17
3.2 Display Backlight (MFT1502 only).....	17
3.3 Label Backlight (MFT1502 only).....	18
4. EEPROM.....	18
5. USER CONTROLS.....	18
5.1 Push buttons .....	18
5.2. Range selection .....	19
6. CONTROL OF HARDWARE .....	20
6.1 Relays.....	20
6.2 Latches.....	21
6.3 Analogue Multiplexers.....	21
7. AD CONVERTERS.....	21
7.1 12-bit Analogue to Digital Converter (7109).....	21
7.2 10-bit Analogue to Digital Converter (UAD) .....	22
8. BUZZER.....	22
9. FLASH PROGRAMMING INTERFACE .....	22
9.1 Flash Programming .....	23
9.2 Remote Control.....	23
9.3 Selection of Calibrate, Final Test or Diagnostics mode.....	23
9.4 RCD Test-gear assist.....	23

10. SPL1000 PROBE (MFT1502).....	24
10.1 Led driver circuit.....	24
10.2 Sensing circuit.....	24
10.3 Blown Fuse detection.....	24
10.4 Torch Section.....	25
11. MISCELLANEOUS.....	25
11.1 Relay board check.....	25
11.2 Display board check.....	25
11.3 Rotary Switches check.....	25
11.4 PLD check.....	25
11.5 Calibration check.....	25
<b>SECTION 2.....</b>	<b>26</b>
1. RCD TEST.....	26
1.1 RCD Test Sequence.....	26
1.2 RCD Test Current Control.....	27
1.3 Loop Measurement – RCD current.....	28
1.4 RCD Thermal protection.....	28
1.5 Power Supplies.....	28
1.6 RCD Final Test Diagnostics.....	28
1.7 RCD Self Check.....	29
1.8 RCD Trip timing.....	29
1.9 Zero crossing detectors.....	29
2.0 PLD.....	29
2. LOOP TEST.....	30
2.1 25A Loop Measurement.....	30
2.2 No Trip Loop test.....	31
2.3 No Trip Loop Final Test Diagnostics.....	32
3. OFF SWITCH POSITION.....	33
3.1 Brief Description.....	33
3.2 Details.....	33
4. VOLTAGE MEASUREMENT.....	34
4.1 Brief Description.....	34
4.2 Voltage Switch Position.....	35
4.3 Pre-test.....	35
4.4 Blown Fuse detection.....	35
4.5 Frequency Measurement.....	35
5. OHMS MEASUREMENT.....	36
5.1 Brief Description.....	36
5.2 Contact detect circuit.....	36
5.3 Ohms & Kohms Source & Reference Circuits.....	36
5.4 Ohms & Kohms Input circuit.....	37
5.5 Blown fuse detection.....	38
6. BUZZER RANGE.....	38
6.1 Brief Description.....	38
6.2 Contact detect circuit.....	38
6.3 Buzzer Range Operation.....	38
6.3 Blown fuse detection.....	38
7. INSULATION TEST.....	39
7.1 Brief Description.....	39
7.2 HV Inverter.....	39
7.2.1 Transformer and FET.....	39
7.2.2 Reference.....	39
7.2.3 Feedback.....	39
7.2.4 Output Voltage Selection.....	40
7.2.5 Oscillator.....	40
7.2.6 Current Limit.....	40
7.2.7 Control Circuit.....	40
7.3 Insulation test voltage measurement.....	41
7.4 Insulation test current measurement.....	41

7.5 Blown fuse detection .....	42
<b>APPENDICES .....</b>	<b>43</b>
<i>Appendix 1 Supplementary Circuit Diagrams.....</i>	45
1. Insulation Meas Board CCT's , HV Inverter & Measurement.....	45
2. Ohms/Buzzer Meas Board CCT's .....	46
3. Ohms Relay Board CCT's .....	47
4. Probe CCT.....	48
5. Voltmeter Relay Board CCT's.....	50
6. RCD CCT Block Diagram.....	51
7. Loop CCT Block Diagram.....	53
APPENDIX 2 CIRCUIT DIAGRAMS.....	55
1. Display CCT.....	55
2. Measurement CCT.....	60
3. Relay CCT.....	73
APPENDIX 3 PCB LAYOUT DRAWINGS .....	83
1. Display PCB.....	83
2. Measurement PCB .....	85
3. Relay PCB.....	88
APPENDIX 4 CALIBRATION .....	91
1. General Description.....	91
2. Calibration Constants.....	91
3. Intelligent Calibration .....	91
4. RCD/ Loop 25A/No Trip Loop Calibration.....	92
4.1 Calibration of RCD Current .....	92
4.2 Calibration of Loop Measurement .....	93
5. Calibration of Voltage / Pretest / Insulation / Continuity.....	95
5.1 Calibration of Voltage Measurement.....	95
5.2 Calibration of Ohms (& kilohms).....	95
5.3 Calibration of Megohms Measurement.....	97
6. Decalibration.....	97
APPENDIX 5 TEST SPECIFICATIONS.....	98
1. Calibration Test Specification 6172-852.....	98
2. Final Test Specification 6172-816 .....	103
APPENDIX 6 INSTRUMENT FINAL SPECIFICATIONS.....	108
<i>Electrical specification.....</i>	108
Voltage range.....	108
Insulation ranges (to EN 61557-2).....	108
Loop ranges (to EN 61557-3).....	108
Continuity (to EN 61557-4).....	108
RCD ranges(to EN-61557-6).....	109
Remote Probe MFT1502 only (Optional on MFT1501).....	109
Power Supply .....	109
Fuses.....	109
Safety.....	109
EMC.....	110
Environmental.....	110
IEC61557.....	110
APPENDIX 7 LIST OF ERRORS – MFT SERIES.....	111
APPENDIX 8 PRODUCTION SOFTWARE / KNOWN PROBLEMS .....	113
Version 1.6.....	113
Version 1.5.....	113
Version 1.4.....	113
Version 1.3.....	113
Version 1.2.....	113
Version 1.1.....	113
Version 1.0.....	113
APPENDIX 9 DIAGNOSTIC MODE.....	114
1. General Description.....	114
2. Diagnostic Tests.....	114

Test 1 - display, and power supplies .....	114
Test 2 - data bus .....	114
Test 3 - push buttons .....	115
Test 4 - Power Supplies .....	115
Test 5 - Switches .....	116
Test 6 - 7109 ad converter.....	116
Test 7 - uprocessor ad converter.....	116
Test 8 - relays .....	117
Test 9 - High voltage inverter.....	117
Test 10 – contact detect circuit .....	118
Test 11 - Kilohms ranges .....	118
Test 12 - ohms ranging.....	119
Test 13 - Serial link (comms).....	119
Test 14 - probe.....	120
Test 15 - eeprom.....	120
Test 16 RCD.....	121
Test 17 Loop.....	122
Test 18 – Dump calibration constants.....	123
APPENDIX 10 INTERBOARD CONNECTORS.....	124
APPENDIX 11 LCD PINOUT .....	132
APPENDIX 12 INSTRUMENT STRUCTURE.....	134
<i>MFT1501 Structure</i> .....	134
<i>MFT 1502 Structure</i> .....	135
APPENDIX 12 A SSEMBLY DRAWINGS .....	136
1. <i>Display PCB</i> .....	136
2. <i>Measurement PCB</i> .....	140
3. <i>Relay PCB</i> .....	141
4. <i>Instrument Assembly</i> .....	145
APPENDIX 13 BOM ‘S/PART NUMBERS.....	151
APPENDIX 14 DISPLAY MESSAGES & BUZZER TONES.....	157
1. <i>Alphabetical List</i> .....	157
2. <i>List by Category</i> .....	160
Messages likely during Normal Operation.....	160
Additional messages likely with untested instrument .....	160
Special Modes etc.....	160
Mode –change Screen.....	161
Diagnostics Mode .....	161
<i>MFT1501 Buzzer Tones</i> .....	163
Warnings – 1kHz (fairly loud).....	163
Continuity Buzzer 2kHz (loudest tone).....	163
Auto loop test – 3kHz (quieter than 1kHz warning).....	163
Keypress beep – 4kHz.....	163
Selective breaker mode.....	163
Calibrate Mode – 3kHz/6kHz.....	163
Diagnostics Mode – 8kHz (very quiet).....	163
APPENDIX 15 KEY PRESSES AND COMBINATIONS.....	164
1. <i>Backlight key</i> .....	164
1.1. Customer mode .....	164
1.2. Final Test mode.....	164
1.3. Calibrate mode .....	164
1.4. Diagnostics mode .....	164
1.5. All modes, except diagnostics .....	164
2. <i>Threshold key</i> .....	164
2.1. Customer mode .....	164
2.2. Final Test mode.....	164
2.3. Calibrate mode .....	164
2.4. Diagnostics mode .....	164
2.5. All modes, except diagnostics .....	164
3. <i>Degree key</i> .....	164
3.1. Customer mode .....	164

3.2.	Final Test mode.....	164
3.3.	Calibrate mode .....	164
3.4.	Diagnostics mode .....	164
3.5	All modes, except diagnostics.....	164
4.	<i>Test key</i> .....	165
4.1.	Customer mode .....	165
4.2.	Final Test mode.....	165
4.3.	Calibrate mode .....	165
4.4.	Diagnostics mode .....	165
4.5	All modes, except diagnostics.....	165
5.	<i>Lock key</i> .....	165
5.1.	Customer mode .....	165
5.2.	Final Test mode.....	165
5.3.	Calibrate mode .....	165
5.4.	Diagnostics mode .....	165
5.5	All modes, except diagnostics.....	165
APPENDIX 16 REMOTE CONTROL MODE .....		166
	<i>Outline Description</i> .....	166
	<i>Calibration</i> .....	166
	<i>Final Test Mode</i> .....	166
	<i>Basic operation of remote mode</i> .....	166
	<i>Communications</i> .....	167
	<i>MFT1501 Control Codes</i> .....	167
	<i>MFT1501 Messages</i> .....	168
APPENDIX 17 OPERATING MODES .....		169
1.	<i>Customer Mode</i> .....	169
2.	<i>Calibrate Mode</i> .....	169
3.	<i>Final Test Mode</i> .....	169
4.	<i>Debug Mode</i> .....	169
5.	<i>Diagnostics Mode</i> .....	169
6.	<i>Local Mode</i> .....	169
7.	<i>Remote Mode</i> .....	169
8.	<i>Other Diodes to aid fault-finding</i> .....	169
9.	<i>No Relay Board Mode</i> .....	169
10.	<i>No Display Board Mode</i> .....	169
11.	<i>Mode Selection</i> .....	170
11.1.	By fitting diodes.....	170
11.2.	By remote control.....	170
11.3.	By the front panel controls .....	170
11.4.	By the test gear interface .....	171

## **Introduction**

The Megger MFT1500 series of instruments are combined multi-function testers; the difference between the 1501 and the 1502 is that the 1502 have a backlight, illuminated range label and is supplied as standard with a switched probe. They are compact battery powered multi-function test instruments designed to enable an electrician to speedily test electrical installations to national and international standards. All the common functions required when testing installations are combined into one instrument and include Voltage, RCD, Loop, Insulation and continuity ranges. The instrument is designed for safety and complies with EN 61010-1 (1993) and the relevant parts of EN61557.

The MFT series was launched at the end of June 2003 to complement the existing CM500 combined tester and also the LCB and BMM.

There are also a 1501E and 1502E variant which are European instruments and merely have a Schuko lead instead of a UK mains lead.

### *PCB Part Number and Edition*

There are three PCB's used in the instrument they are as follows: -

Measurement PCB 5240-421 Ed A4/A5

Relay PCB 5240-420 Ed A6/A7

Display PCB 5240-419 Ed A4/A5/A6

This manual only refers to these editions of artwork. The part numbers and edition of the PCBs in the instrument can be found on the PCB marked in the copper.

## **Safety Precautions**

While servicing the instruments suitable protection from mains supply voltages will need to be provided. For instance when measuring voltage this can include a 30mA RCD, isolation transformers and barriers.

High Voltages up to 1000V may be present inside the instrument, and capacitors may remain charged after test.

Take care to mark the position of all cable and wire fastenings on dismantling the instrument, and reinstate these after service.

Ensure that the split line insulator is in place and is not damaged. This is relied on for safety and maintains the creepage and clearance to the outside world.

All replacement items must be of a type approved by AVO International Ltd to maintain product safety.

Before a repaired instrument is returned to the user a full test must be performed to ensure that the instrument is safe to use.

All protective devices (fuses) must be present and fully operational.

## **Disassembly and Re-assembly**

### **1. Disassembly**

First disconnect all test leads, open the battery compartment and unclip the battery holder from the instrument. Peel off the label from the front cover and remove the four screws. Turn the instrument on its side and remove the four case screws. The front panel can now be lifted off, disconnect the ribbon cable and put to one side. The instrument case halves can now be separated by slowly prising apart the cases leaving the terminal housing with the relay board side. Remove the silicon cord around the top of the case, take off the rubber cover, feed the battery connector back through the hole in the battery compartment and disconnect the two ribbon cables, which attach between the two main boards. The instrument can now be separated and the two halves placed flat on the bench.

To remove the display PCB remove the two retaining screws and pull the PCB out of the moulding, the range knobs will fall off but doing it this way prevents any damage to the knobs if they are attempted to be pulled off with pliers.

To remove the micro PCB firstly the daughter board needs to be removed by undoing the four screws securing it and then unplugging it from the main board. The main board can then be removed by undoing its retaining screws.

The relay board can be removed by following the same procedure as the micro board but the terminal housing must be taken out with the relay daughter board.

The boards can now be re-connected outside of the case and laid flat on the bench ready for fault finding.

Particular attention needs to be paid to the inter-board connections both ribbon and sockets to ensure that they are properly fixed and making connection otherwise spurious faults may appear.

### **2. Display removal**

The only components under the display are the backlight (1502only) and the display connector connections. If a display fault is obvious (e.g. marks or cracks), it is easier to cut the legs with a pair of wire cutters and then clean up the PCB afterwards. If the backlight must be removed, extreme caution should be used if damage is to be avoided. This component is quite fragile, as the four connection points are not metal pins, but small strips of double-sided pcb material, which can easily break off. Re-assembly is straightforward, but it is worth checking that everything is working correctly beforehand. Clean the PCB holes of solder and bend the legs of the display slightly outwards so that it can be 'sprung' into place with the legs making contact with the PCB. (The epoxy seal on the display should be on the left-hand side, when viewed from the front). If there are contact problems, water can be applied sparingly with a small paint brush to each leg in turn, which will make adequate connection for a short while. Do not get water onto any other part of the circuit, as some parts are very sensitive to leakage. Dry the board afterwards with gentle heat, such as warm air from a hair-dryer. Do not forget to fit the backlight before final re-assembly.

### **3. Rotary switch.**

These are low voltage switches of simple construction, and indication of position is provided by two voltages. See circuit diagram for a table of expected voltages. The fixed contacts are copper PCB pads, coated with Electrolube grease to reduce oxidation. The moving contacts are nickel-silver discs, one each side of the board, each having three points of contact. Two helical springs hold the discs in contact with the board. The spring pressure is sufficient to clean away dirt and contamination as the discs rotate. The resistance of the switch should not exceed 5ohms at each point of contact.

Life expectancy is 100,000 operations with the correct lubricant, when the discs will need replacing. A similar life will be obtained even without lubrication, the main purpose of which is to prevent the build up of copper oxide when the instrument is not used regularly. If the switch is disassembled and cleaned, it may be re-lubricated with almost any contact grease.

The switches can be disassembled by removing the centre screw. Re-assembly simply involves lining up the internal keys of the two halves of each switch and screwing them together ensuring that the correct switch half is on the right side of the board. The switch components are captive and held in place by the switch ring which has small barbs securing it to the main body of the switch. This can be removed if necessary and replaced.



## **4. Reassembly**

This re-assembly procedure assumes that the instrument has been stripped down and the boards separated. You may need up to six cable ties (AVO part number 25274-417) if the wiring loom from the terminal has been disassembled. These hold the wires internally to prevent the failure of a soldered joint causing a safety hazard.

Before screwing the micro main board in ensure that the rubber keypads are correctly positioned. Screw the board in and then plug the daughter board into the main board and screw that down. Position the insulator at the curved end of the case. Fit the battery connector and make sure that the strain relief tie wrap is fitted. The cable clip should position the battery lead in between the on-board fuse and the 220uF capacitor.

Now fit the relay main board into the other case half and secure. Fit the relay daughter board with terminal wires attached to the main board and secure with the four screws. If the terminal wires have been disconnected the correct wiring is as follows: -

Labels for the wires are marked in the PCB resist, and relate to the following connections.

PRB	Unsleeved long Blue wire.
0V	Unsleeved long Black wire.
L	Sleeved Red from +ve/L1 terminal.
E	Sleeved Green from -ve/LO terminal.
N	Sleeved Black from NO TRIP terminal.

If, for any reason, the terminal wires need re-soldering, a heat-sink must be inserted into the terminals to avoid the mouldings softening and distorting the terminal housings. The instrument's test-leads can be used.

To fit the display PCB first fit the rotary switches and position the o ring seals around the splines. Position the switch on the right so that the ident tail points at 6 o'clock when viewed from the display side. Position the inner most switch with the ident tail pointing towards 3 o'clock. Now fit the board to the front panel. Fit the innermost range knob so that the OFF position is selected and the right hand knob so that 100mA is selected. Some wiggling of the switches may be necessary until they are fully engaged with the front cover ident mechanism. Screw the board to the front cover with the two securing screws. Check that the rotary switches work as expected.

The instrument cases can now be re-assembled. First make sure that the re-enforcing pins are fitted to the carry strap fixing points also make sure that the insulating sheet is correctly fitted to the case half with the buttons.

Now with the instrument case halves standing up, position the insulator so that it fits inside the opposite case half, then connect the two main ribbon cables to the relay main board. Push the battery connector back through the hole in the battery compartment, make sure that the rubber boot cord is fitted over the carry strap fitting nearest the terminal end and then ease the two halves together until they are touching. Make sure that the insulator is correctly fitted and that the battery connector is pulled all the way through and is not trapped by the PCB's.

The top panel can now be fitted, fit the silicon cord to the recess in the top of the cases and connect the display board to the ribbon cable. Position the front panel on the case and loosely tighten the four screws. At this point a battery can be temporarily attached to check that the instrument powers up. Now put the instrument on its side and fit and screw up tight the four case half screws in the correct sequence (as per the assembly drwg). Now tighten up the front panel screws and fit a new range label.

Fit the battery holder with the connectors positioned top left of the battery compartment as you look at it, if this is incorrectly fitted then the battery cover will not fit properly. Now screw the battery cover on.

### **Critical Components**

The following components are safety related and if faulty must be replaced by an approved part. When inspecting an instrument for a suspected fault, these components must be checked for damage before connecting the instrument to any supply voltage.

### **High Integrity Components**

The following components are HIGH INTEGRITY. This means that the safety of the customer relies on these components. You therefore need to be sure that the correct components are used.

Relay PCB Circuit Reference	Description	Part Number	Manufacturer and Reference
R106,R114,R108	Resistor 750k VR37	26837-066	Philips VR37 5%
R133,R141,R135,R148, R122,R145,R131,R118, R158,R32,R24,R33	Resistor 10M VR37	26837-130	Philips VR37 1%
FS2,FS3 Fuse 7A	600V F Type 50kA HRC	25411-854	SIBA 70 094 63
FS1 Fuse 500mA	500V F type 10kA HRC	25950-039	SIBA 70 065 63

### **Overload protection components**

#### Measurement PCB

Circuit reference	Description	Part Number	Manufacturer and Reference	Rating
D27/D26/D22	Diode 1N4007	28863-082	1N4007 (1000 V)	1kV
D21	Diode 1N5339B5 Zener	28920-062	1N5339B	5.6V, 5% ,5W
D20/D25	Diode BA159	28863-160	BA159	1A,1000V
D19/D24	Diode 1N4007	28863-082	1N4007 (1000 V)	1kV
D11	Diode 1N4007	28863-082	1N4007 (1000 V)	1kV
D23	Diode BY448	28920-064	BY448(1500V)Fast Recovery	1500V

#### Relay PCB

D18,D17,D16,D14	Transorb P6KE440P	27920-039	ZENER TVS.600W UniDir	440V
D10/D11	Transorb P6KE440P	27920-039	ZENER TVS.600W UniDir	440V
D31	ZENER TVS. BiDi	28920-047	SA12CA	12V 500W
RL1/RL2/RL3/RL4	Relays	25980-057	Takamisawa JS5-K	1 kV a.c. rms

## **MFT Series Circuit Description**

### **Overview**

The pair of boards which contain the microcontroller and the hv inverter is referred to in this document as the 'measurement' board, or sometimes as the 'micro' board. The other pair of boards is the 'relay' board. In both cases the smaller plug-in pcb is referred to as the 'daughter' board. The suffix '\_D1' is used in signal names on the circuit diagrams to denote that the signal net is on a daughter board. The final pcb in the instrument is the 'display' board. Additionally, the SPL1000 probe contains two pcbs, the 'fuse' board and the 'switch' board.

#### MFT1500 Functions

The instrument has the following features:

- A. Measurement of insulation resistance at 250V/500V/1000V
- B. Measurement of resistance (at low voltage) up to 100kΩ
- C. Quick response continuity buzzer with adjustable threshold
- D. Measurement of a.c & d.c. voltage up to 500V
- E. RCD testing at ½ I, I, 5I, for Standard a.c. operated trips
- F. RCD testing at rated current for selective type a.c. operated trips
- G. RCD testing at rated current for d.c. operated trips
- H. Trip current determination for a.c. trips (ramp test)
- I. Standard Loop impedance testing (high current)
- J. Non-tripping Loop impedance testing (low current)
- K. PSC measurement
- L. In addition, the MFT1502 has an automatic/manual backlight and an illuminated switched-probe accessory.

### **Circuit Organization**

The overall arrangement within the instrument is that essentially independent blocks of circuit for each type of test (RCD/loop, insulation, etc.) share a common core which is responsible for control, measurement and display. To reduce battery drain, some parts of the circuit used during RCD/Loop are powered down when not required.

The shared group of circuits consists of:

- A. Rotary Switches.
- B. Push buttons.
- C. Display & Display Controller.
- D. Power supplies
- E. Microcontroller system
- F. Input/output expansion (latches)
- G. Input terminals switching (relays)
- H. AD converters & associated multiplexers
- I. Eeprom for storage of calibration constants etc

When a test is carried out, the particular block of circuit relating to that test is connected to the AD converter circuits via semiconductor multiplexers, and to the instrument terminals by means of mains-rated relays.

## **Pre-test**

'Pre-test' refers to the operation of the instrument before a test is attempted, or after a test has been completed.

The following activities occur during pre-test:

- A. Check to see if the input voltage is a.c. or d.c.
- B. Perform quick measurements on all three input voltages.
- C. Check pushbuttons, including SPL1000 probe (every 100ms)
- D. Control SPL1000 probe led (every 100ms)
- E. Check remote control input buffer (every 100ms)
- F. Check rotary switches (every 400ms)
- G. Check battery (every 1.6 seconds)
- H. Read temperature of heatsink (RCD/Loop only)
- I. Refresh hardware settings
- J. Display results, symbols etc., as required.
- K. Transmit results (special modes, as required)

During Pre-test all relays are de-energized, and the instrument checks the conditions according to switch position, to see if a test should begin.

The voltage must always be within defined safe limits before a test is allowed.

The conditions required for a test to start are as follows...

Insulation: test button pressed and <55V present on terminals

Ohms/Buzzer: resistance less than 150kΩ between L-E terminals, and <10V present on terminals.

Voltage: test starts automatically.

RCD: test button pressed, with >100V (but <270V) on L-E terminals, with <50V N-E

Non-tripping Loop Test: >55V (but <270V) L-E and L-N, with <50V N-E. Test starts automatically, or press test button to repeat.

25A Loop Test/PSC: >55V (but <460V) L-E, with <50V N-E. Test starts automatically, or press the test button to repeat.

In the circuit description which follows, Section 1 deals with the general-purpose circuit blocks, while Section 2 goes on to describe the workings of the individual tests.

# MFT 1500 Block Diagram

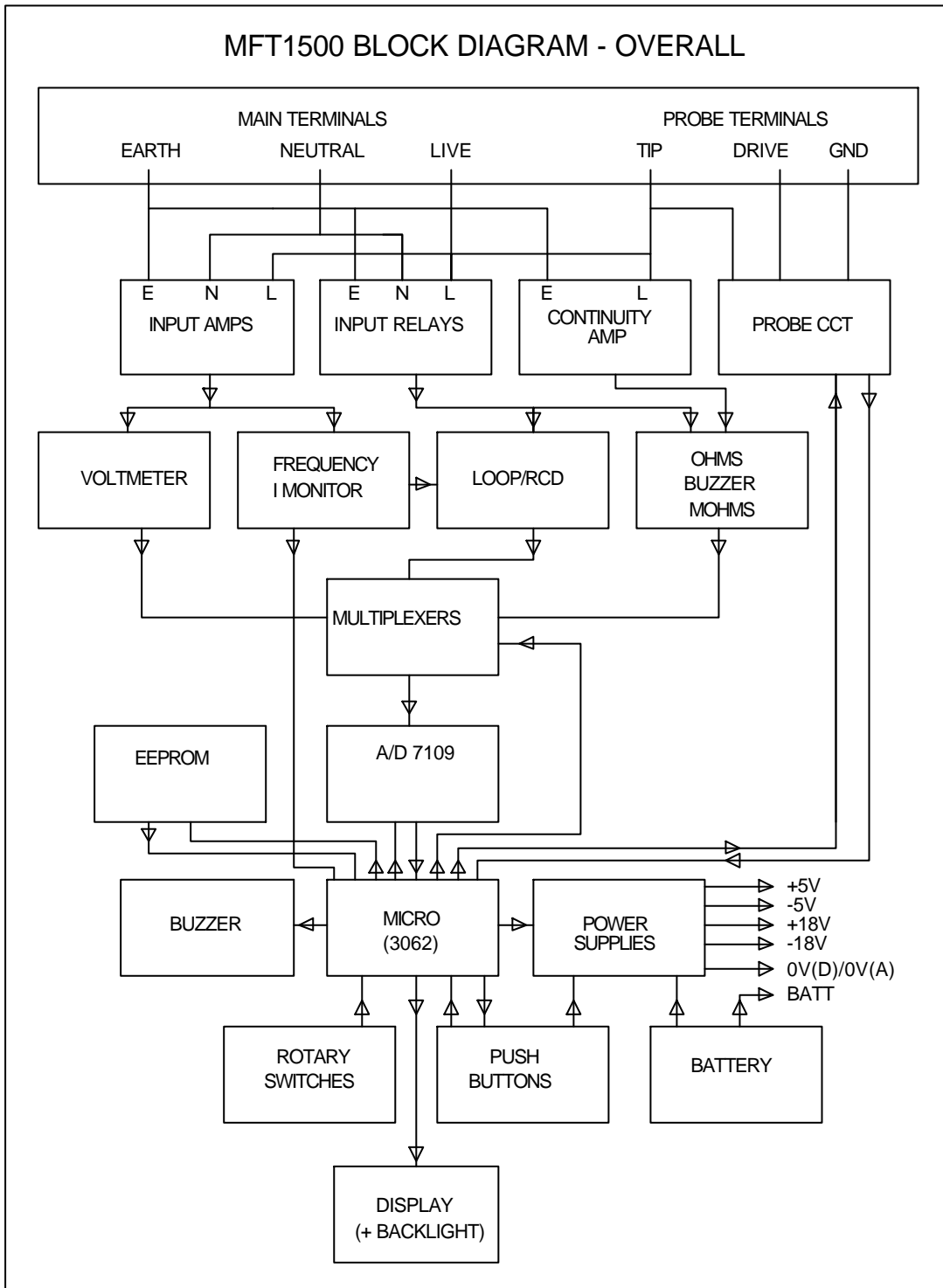

## SECTION 1

Note: Some supplementary circuit diagrams are available which combine sections from two or more sheets onto a single sheet.

### 1. Power Supplies

This section includes...

- Battery
- Battery Check circuit
- Power on/off circuit
- 0V Rails
- +5V Supply
- 5V Supply
- +18V Supply
- 18V Supply
- Supply Self-Check

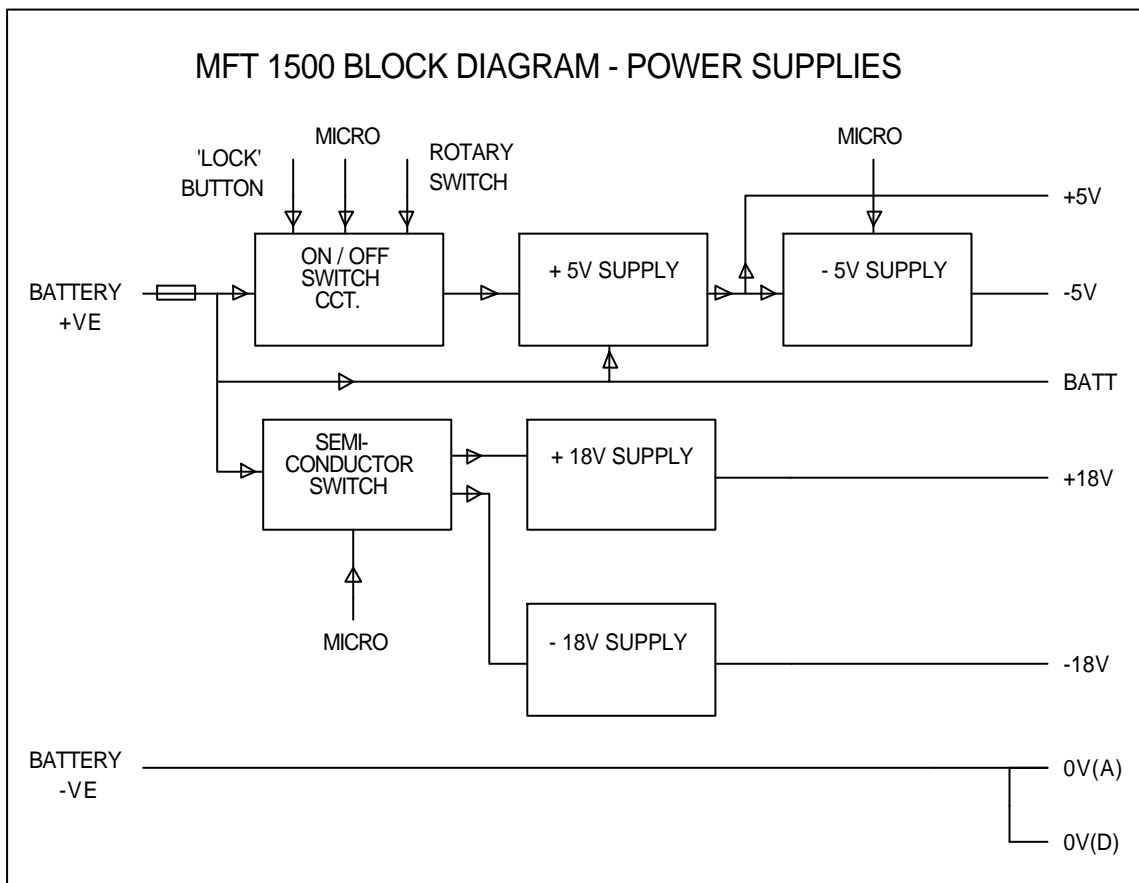

## **1.1 Battery**

A few circuits are powered directly from the battery.

- HV inverter transformer (measurement board sheet 1)
- Battery check circuit (measurement board sheet 10)
- 'Lock' button (measurement board sheet 10)
- Power 'on/off' switching circuit (measurement board sheet 11)
- 5V supply generator, IC3 (measurement board sheet 11)
- 18V supplies switch, TR2 (measurement board sheet 11)
- Display Backlight (display board sheet 2)

The instrument is protected against battery reversal by the combination of the polyfuse FS1 (measurement board sheet 11), and the parasitic reverse diode within TR8 (the HV inverter switching fet, measurement board sheet 1). Initially, high current flows through these components, but subsequently the polyfuse heats up and becomes high resistance, limiting the current to a few mA.

## **1.2 Battery Check circuit**

(See measurement board sheet 10)

When the instrument is powered up, TR6 is 'on', which turns on TR4, connecting the divider chain R30/R22/R19 across the battery. One third of the battery voltage appears across R19 (on 'UAD\_BATT\_DIV\_3'), and this is directed through the analogue multiplexer IC18 (sheet 7) to the microcontroller AD converter (UAD).

Key values for the battery voltage are...

- 7.5V - Battery low symbol turns on
- 6.5V - Battery low symbol flashes
- 6.0V - Auto shutdown
- 4.4V - NMI (generated independently of the battery check circuit)

When the MFT is switched off, there is no 5V rail, and therefore TR6 & TR4 are both 'off', disconnecting the divider chain R30/R22/R19 to save power.

Note: To assist in fault-finding in the event of a battery measurement error, diode D46 (measurement board) can be fitted temporarily. This tells the MFT to bypass all the battery voltage checks. For example, if the battery reads very low due to a hardware fault, the MFT will automatically keep shutting down. Fitting D46 prevents this from happening.

## **1.3 Power on/off circuit**

(See measurement board sheet 11)

The 'on/off' circuit controls the 5V supply by means of the 'SHDN-' pin on the 5V generator chip, IC3. This pin connects internally in IC3 to a source which can supply a few microamps. To turn the 5V supply on, 'SHDN-' must connect to a high impedance only, so that it pulls itself up to >2.4V. To turn it off, 'SHDN-' must be pulled down below 0.4V. These conditions are achieved by turning transistors TR13/TR15 on or off. The on/off circuit is basically a bi-stable latch formed by pairs of transistors TR10/TR11 and TR13/TR15. The latch is flipped into the 'on' state by a pulse on TR10 base (from the 'lock' button or the rotary switch), and flipped 'off' by a pulse on TR15 base from the microcontroller. When the rotary switch is in the 'OFF' position, it mechanically shorts 'POWER\_SWITCH\_MIDDLE' to 0V(A), and 'INSTRUMENT\_OFF' is also low because the microcontroller is not powered up. When the switch is turned away from 'OFF', the 'POWER\_SWITCH\_MIDDLE' signal is pulled up by R38, turning on TR7 and applying the required 'on' pulse through C27 to TR10/TR11. TR13 and TR15 are now both turned off and the '5V\_ON' signal is pulled up by IC3, turning on the 5V supply. To power down, the microcontroller sets 'INSTRUMENT\_OFF' to a high level. This causes TR15 to turn on, thereby pulling down '5V\_ON' and shutting down the power. The 'OFF' current consumption should be <75uA.

## **1.4 0V Rails**

Five 0V rails are available, all of which are the same potential as the low side of the battery.

0V(A) - ground for analogue circuitry, originating at PL1 (measurement board sheet 11), and also used for the copper pour on the solder side of the pcb.

0V(B) – ground for the high currents in the primary circuit of the HV inverter. Originates by PL1 (measurement board sheet 11).

0V(D) - ground for digital circuitry, microcontroller etc., originating at the battery connector PL1 (measurement board sheet 11), and also used as a ground plane on one of the inner layers of the pcb.

0V - ground for precision measurements, originating at the low end of resistors R111 & R114 in the ohms reference circuit (measurement board sheet 2). Very little current flows along 0V so that its potential is essentially the same everywhere in the instrument. The 0V signal is used for copper pour on the smd layer.

RELAY 0V – ground for relay coils. See later section describing relay operation.

## **1.5 +5V Supply**

(See measurement board sheet 11)

The 5V supply is generated by a step-down switching regulator circuit, consisting primarily of IC3, D7, L3 and C16, plus feedback components R40/R41 and R46/47. The ‘on/off’ switch for the 5V supply (IC3) is the ‘SHDN-’ pin, which must be taken above 2.4V for ‘on’ or below 0.4V for ‘off’.

IC3 converts battery voltage into 5V using a switched inductor method, running at a fixed frequency of about 400kHz. The battery supply on IC3 pin 2 connects via an internal switch to pin 1 (‘Vsw’), and therefore to inductor L3. A switching cycle within IC3 starts with this switch ‘on’, and so current flows from the battery via L3 into the output capacitor C16. The current ramps up linearly until it reaches a fixed trip level set within the IC, at which point the internal switch is turned ‘off’. The battery is now disconnected, but inductor current continues to flow into C16, (the current loop being completed by D7), until L3 has given up all its stored energy. Then the cycle starts over again. Control over the voltage is achieved by feeding back a fraction of the output to the ‘FB’ point (pin 6) of IC3 (via R40/R41/R46/R47). The voltage here is compared to an internal reference, and an internal error voltage controls the current trip point of the system. During normal operation, the ‘FB’ pin should sit at 1.2V. The combination of D13 and C22 – C24 provides a boosted voltage to drive the base of the internal transistor switch, which improves efficiency.

## **1.6 -5V Supply**

(See measurement board sheet 11)

The –5V supply is always ‘on’ except during initialization. It is produced by the action of IC6, C39 and C42. The ‘on/off’ signal is ‘-5V\_SUPPLY\_ON’ from the micro, which controls the ‘SHDN-’ pin on IC6. An oscillator within IC6 controls a process which transfer charge from the +5V supply to produce an equal –ve supply. First, internal switches close, which connect ‘C+’ (pin 2) to +5V and ‘C-’ (pin 4) to 0V(D). C39 therefore charges to +5V. Then the first pair of switches open and another pair connect ‘C+’ to 0V(D), and ‘C-’ to the ‘OUT’ pin. The voltage on C39 is therefore level shifted downwards, which produces a negative voltage on C42. This is slightly less than –5V because of losses in the system. This rail is used as the copper pour on one of the inner layers of the pcbs.

## **1.7 +18V Supply**

(See measurement board sheet 11)

The +18V supply is used in measurement circuits for RCD & Loop tests, and is only turned ‘on’ when required. It is generated by a step-up switching regulator circuit, consisting primarily of IC2, D1, L2 and C3, plus feedback components R5 – R8. The ‘on/off’ switch for the 18V supply is the control line ‘18V\_SUPPLY\_ON’. This is inverted by TR1 in order to control a pair of fet switches which connect the IC to the battery. The operation of this supply is similar to the +5V supply, but with slightly different topology, as the semiconductor switch in IC2 is positioned at the low end of the inductor. During normal running, 1.2V should be present on the ‘FB’ pin.



## **1.8 -18V Supply**

(See measurement board sheet 11)

The -18V supply is used in measurement circuits for RCD & Loop tests, and is only turned 'on' when required. It is generated by a switching regulator circuit, consisting primarily of IC1, D2 & D3, L1 and C1, plus feedback components R1 – R4. The 'on/off' control is as for the +18V supply. The operation of this supply is similar in principle to the +5V and +18V supplies, but again with different topology in order to generate a negative rail. During normal running, -1.2V should be present on the 'FB' pin.

## **1.9 Power Supply Self-check**

(See measurement board sheet 9)

The -5V, +18V and -18V supplies have self-check capability.

A pair of resistors on each supply forms a divider, producing a voltage between 0V and 5V, which is fed to the UAD. If this is found to be outside certain limits, then an error message is generated.

On the -5V rail, for example, resistors R13 & R15 should cause about 1.8V to be present on 'UAD\_-5V\_CHECK'.

For the 18V supplies, R9 & R12 should provide around 3.2V on 'UAD\_18V\_CHECK', and R11 & R10 give 1.9V on 'UAD\_-18V\_CHECK'.

The 2.5V reference from D29 (sheet 6) is also checked, directly through R156.

## **2. Microcontroller system.**

This sub system consists of:

- Microcontroller
- Reset circuit
- NMI circuit

### **2.1 Microcontroller**

(See measurement board sheet 7)

The microcontroller IC27 is an HD64F3062BF25 type manufactured by Renesas (Hitachi). It has on-board 4kbytes of RAM and 128kbytes of flash-programmable ROM (containing the program instructions). The oscillator runs at 10MHz (XL1), and an internal divide-by-4 is used to generate a 2.5MHz system clock which is outputted on the 'phi' pin (pin61).

The micro has a built-in 10-bit 8-channel AD converter with a conversion time of a few microseconds, plus numerous timers, interrupt pins and two serial interfaces. Port usage is mostly general purpose input/output, but some ports have special functions.

Port 1 – General purpose Input/Output

Port 2 – Latch enables and PLD test pins

Port 3 – Pseudo-data-bus to interface with the 7109 AD converter, test buttons etc.

Port 4 - Digital pots and general purpose I/O

Port 5 – Display controller and general purpose I/O

Port 6 – Display controller and general purpose I/O

Port 7 - 8 channel 10-bit a/d converter, referred to in this document as the UAD

Port 8 – General purpose I/O

Port 9 – Communications & Flash Programming Interface

Port A – General Purpose I/O

Port B – General Purpose I/O

## **2.2 Reset Circuit**

(See measurement board sheet 9)

IC20-1 is configured as a monostable to generate the microcontroller reset pulse.

At power-up, C75 & C76 are discharged, resetting IC20 and forcing pin 4 ('RESET-') high. C76 charges faster than C75, giving a high level on pin 3 which enables the monostable action to be subsequently triggered by the rising edge on pin 2. The 'RESET-' line then pulses low for a period of about 40ms, which is set by R196 & C78.

## **2.3 NMI Circuit**

(See measurement board sheet 9)

The NMI signal is normally high, but set to change state if the 5V rail dips below 4.4V. A fraction of the supply set by R200/R199/R202 is compared to the system 2.5V reference on comparator IC21-4. The low pass filter R265/C107 rejects very fast spurious events which can occur when the instrument terminals are shorted during an insulation test. The NMI signal causes the microcontroller to display the warning message 'bAT' and then execute an ordered shutdown followed by an automatic reset.

## **3. Display, Display Controller & Backlight**

This section describes...

- Display & Display Controller
- Display Backlight
- Label Backlight

### **3.1 Display and Display Controller**

(See display board sheet 2)

The display LC1 is driven in 3-way multiplex, 1/3 bias mode, by 3 'common' signals (backplanes) and 38 'driver' signals from the controller chip IC1.

During the MFT start-up sequence, the signal 'DISPLAY\_BLANK-' is held low to blank the display while IC1 is initialized. 'DISPLAY\_BLANK-' is then taken high and remains high for almost all of the time. The other control signals are normally low. The bias levels for the LCD drivers (VLC1 etc.) are tapped off from the resistor chain R1, R2, R3 & R5. Components R4 & C3 set the clock frequency, which in turn defines the multiplexing rate.

For a general-purpose write to the display controller, data for a particular 'common' is sent in one frame, followed by data for the other commons in successive frames. For each 'common' write, 'DISPLAY\_CLOCK' is toggled rapidly to generate a system clock, while 'DISPLAY\_DATA' outputs a bit pattern corresponding to the desired outputs of the driver pins. Then 3 dummy zeroes are clocked in, followed by data to select which 'common' is being written to. Finally, the new data is latched in by pulsing 'DISPLAY\_LOAD' high.

The act of turning a single display segment 'on' or 'off' takes a few milliseconds, so the MFT usually performs 'virtual writes' to reduce execution time. The microcontroller keeps a memory map of the display contents, and during a 'virtual' write, only the memory map is altered, which is a fast operation. Then, after a number of such virtual writes, the display controller is refreshed, thereby effecting all the display changes in one operation.

The unused driver pin 48 on IC1 (TP11) always provides a 'segments-on' test signal, which should be a square wave of about 4V pk-pk. Driver pin 47 (TP12) provides a 'segments-off' test signal of about 1.3V pk-pk.

### **3.2 Display Backlight (MFT1502 only)**

(See display board sheet 2)

The backlight (BL1) is an led type having a row of leds along each of the short edges. To prevent the backlight current from disturbing the 5V rail, the leds are driven from the battery rail. Quasi-constant current sources are used so that the brightness does not vary with battery voltage. When the 'BACKLIGHT ON' signal is high, TR3 is turned 'on' and a voltage is developed across D1 & D2 which is approximately independent of the supply. The volt-drops across TR1/TR2 b-e junctions

are also fairly constant, resulting in equal controlled currents through both sets of leds, via R10-R12 & R13-R15. A plastic diffuser in the backlight spreads the light fairly evenly across the full width of the display.

The backlight can operate in 'manual' or 'intelligent' mode. In 'manual' mode the backlight is toggled 'on' or 'off' by the 'backlight' button. When in 'intelligent' mode, the backlight also turns on automatically when any 'event' occurs. 'Events' are such things as button pushes, a test finishing, rotary switches being moved and so on. The backlight always turns off automatically after about 5 seconds, to save battery power.

### **3.3 Label Backlight (MFT1502 only)**

(See display board sheet 3)

Leds illuminate the back of the front panel label so that it can be seen in poor light conditions. The leds are driven from latches IC2, IC3 & IC4 (sheet 5). Pairs of resistors R18/R21 etc., set the led currents to be about 20mA. The MFT software decides which leds should be 'on' according the positions of both rotary switches, and writes appropriate data to the latches. During normal running of the instrument, the leds always operate synchronously with the display backlight. At start-up, all the leds are briefly illuminated in a rotating sequence.

## **4. EEPROM**

(See measurement board sheet 10)

Eeprom IC26 is an 8kbyte non-volatile memory, which stores calibration data, and certain other parameters such as ohms null. There is little to go wrong with the EEPROM system as it has a simple 2-wire serial link direct from the microcontroller. However, since the eeprom uses an open-drain output for 'EEPROM\_SDA', it cannot function without the pull-up resistor R225. Information is clocked in or out of the device by the 'EEPROM\_SCL' signal while the data is presented or read on the 'EEPROM\_SDA' line.

Note: To assist in fault-finding in the event of an EEPROM error, diode D44 (measurement board) can be fitted temporarily. This tells the MFT to bypass all EEPROM action, allowing the instrument to run without the errors getting in the way.

## **5. User Controls**

This section contains...

- Pushbutton Sensing
- Range Selection

### **5.1 Push buttons**

(See measurement board sheet 10)

The 'lock' button is connected directly to the battery supply, so that it can apply a voltage pulse to the power supply on/off circuit at any time in order to wake the instrument from shutdown. This signal is also clamped to 5V by D39 & R251/R252/R253 before being routed to the microcontroller. The other push buttons ('degree', 'threshold', 'backlight' and 'test') are sensed in a different manner. Normally the signal 'READ\_KEYS-' is high and so diodes D37/D31/D32/D30 are either unconnected or reverse biased, depending on the condition of the buttons. Periodically, (about every 100ms), 'READ\_KEYS' is pulsed low, and during the low period the data bus lines are read so that the status of the pushbuttons can be determined. The auxiliary diodes D44 – D47 are read in the same way, but only once, during the start-up sequence. Diodes D40 – D43 and D48 – D51 are read during start-up by pulsing the 'READ\_DIODES' signal low.

Note: The 'test' button in the Probe operates in a completely different manner, as described in the section on the SPL1000 probe

## **5.2. Range selection**

(See display board sheet 4)

On each of the rotary switches, a chain of 6 resistors is connected between 0V(A) & +5V to provide a set of voltage tapplings (R62/R64/R65/R67/R68/R69 for the main switch and R71/R72/R74/R75/R76/R77 for the current switch). Each switch selects 2 tapplings in different combinations according to its position. The two voltages from each switch are routed through analog multiplexer IC12 (measurement board sheet 7) in order to be measured by the UAD – the UCONTROLLER AD converter. The signals are ‘UAD\_MAIN\_SWITCH\_A’, ‘UAD\_MAIN\_SWITCH\_B’, ‘UAD\_CURRENT\_SWITCH\_A’ & ‘UAD\_CURRENT\_SWITCH\_B’. Each voltage is measured in turn, and a look-up table in the software determines which tapping points have been selected. A second look-up table then identifies the angular positions of both switches. The ‘OFF’ switch position does not directly turn the power off by hardware. If the ‘OFF’ position has been selected for about 1 second, the microcontroller initiates a controlled shutdown sequence and turns off all power supplies.

Table of voltage against tapplings numbers for the ‘\_A’ and ‘\_B’ switch signals...

<b>Tapping</b>	0	1	2	3	4	5	6
<b>Voltage</b>	0.00V	0.82V	1.63V	2.44V	3.26V	4.11V	5.00V

Table of tapping numbers against switch position for the ‘main’ switch...

SWITCH POSITION	_SWITCH_A TAPPING	_SWITCH_B TAPPING
DIAGNOSTICS	6	6
DIAGNOSTICS	0	6
1000V INSULATION	0	5
500V INSULATION	5	5
250V INSULATION	5	0
BUZZER	4	0
OHMS	4	4
VOLTAGE	0	4
OFF	0	3
RCD ½ I	3	3
RCD I / SELECTIVE	3	0
RCD 5I	2	0
RCD I TRIP (RAMP)	2	2
RCD DC SENSITIVE	0	2
LOOP NON-TRIPPING	0	1
LOOP 25	1	1
PFC	1	0

Table of tapping numbers against switch position for the ‘current’ switch...

SWITCH POSITION	SWITCH_A TAPPING	SWITCH_B TAPPING
10mA	4	4
30mA	0	4
100mA	0	3
300mA	3	3
500mA	3	0
1000mA	2	0

Note: If neither of the range switches are fitted, the instrument defaults to its voltage range. See Rotary Switches Check

## **6. Control of Hardware**

This section includes

- Relays
- Latches
- Analogue Multiplexers

### **6.1 Relays**

(See relay board sheet 1)

Four high-voltage relays are used to connect the instrument terminals to the appropriate measurement circuits, according to switch position.

The relay coils are driven via transistor switches which invert the output signals from the relay control latch. The latches themselves do not have enough drive capability.

To ensure that the relays do not turn on accidentally when not required, there is also a ‘MASTER\_RELAY\_ENABLE’ signal which comes direct from the microcontroller. This drives a transistor switch (TR14) which can connect or disconnect the low end of all the relay drivers (RELAY\_0V) from 0V(D). ‘MASTER\_RELAY\_CONTROL’ is low during start-up, pre-test and voltage measurement, but high during most other tests. The condition of TR14 is latched by TR15, so that the status is preserved in the event of an unexpected microcontroller reset. The relays are always operated one-at-a-time in a controlled sequence, otherwise indeterminate conditions can occur due to differences in relay switching times. FS2 provides back-up protection in case an invalid relay combination occurs.

In addition, there is a low voltage relay on the measurement board (RL1, sheet 2) which switches between the reference circuits for ohms and for kohms/Mohms. This relay is de-energized during all tests except kohms and Mohms.

## **6.2 Latches**

(See measurement board sheet 8, relay board sheets 3 & 7, display board sheet 5)

These are used for general-purpose control of relays, analogue switches and other circuit elements. They act as outputs only and cannot be used as inputs. They are of 8-bit addressable type. Only one output pin can be written to at any given time. The 'LATCHX\_ENABLE-' line is normally high. The address of the bit to be written is set up as a binary pattern on 'D(0)' - 'D(2)'. The data to be written is set up on 'D(3)'. The 'LATCHX\_ENABLE-' signal is then pulsed low for a few microseconds, during which the level on 'D(3)' ('DATA IN'), is copied and latched into the selected output. To write to the entire latch, this process occurs eight times, selecting each bit in turn. A problem with latches is that unwanted noise glitches on the 'LATCHX\_ENABLE-' line can cause random data to be written. Thus the latches have a small capacitor fitted locally on the 'LATCH X ENABLE-' signal. The relay control latch (IC10, relay sheet 3) is critical, and to achieve even greater noise immunity, its enable line has a larger capacitor (10nF) and a high current push-pull driver (TR26 & TR27 on measurement board sheet 12). As an additional anti-noise measure, all the latches are refreshed regularly, i.e. all the data it is periodically rewritten from copies which are held in RAM. Each latch also has an RC network connected to its 'RESET-' pin, which serves to clear all the outputs to logic 0 at power-up.

## **6.3 Analogue Multiplexers**

(See measurement board sheets 5, 6 & 7, relay board sheets 3 & 4)

These are mostly used to direct measurement signals from various parts of the circuit to a key point such as the 7109 AD or the microcontroller.

The 4051 type are 1-pole 8-way switches. Three control pins 'A' 'B' and 'C' select which way the switch points, with 'C' being the most significant control bit, (i.e. A=0, B=0, C=1 selects channel 4).

Type 4052 are 2-pole 4-way, and have 2 control pins 'A' and 'B' for channel selection, and a master inhibit which turns all channels off if taken high.

4053 type switches have 3 control pins ('SW'), one for each switch in the package. The circuit diagram symbol for the 4053 shows the condition which occurs when the control signals are low.

There is no latching action on the analogue switches - the desired control signals must be maintained at all times.

## **7. AD Converters**

This section describes...

12-bit AD (7109)

10-bit AD (UAD)

### **7.1 12-bit Analogue to Digital Converter (7109)**

(See measurement board sheet 6)

The 7109 12-bit integrating converter (IC11) is used for all the accurate measurements. The AD reference voltage is constant for some types of tests and variable for others. The fixed references are obtained by dividing down the 2.5V from bandgap diode D29, to 1.0V for voltage measurement, 100mV for low current (15mA) loop and 480mV for all other loop tests.

For ohms, kohms, and Mohms measurements the AD converter is used in ratiometric mode, whereby both the input and the reference may vary. Also, on ohms, kohms, and loop, differential input mode is used, meaning that neither input to the AD is kept at a fixed voltage. The HI input is switched by the analog multiplexer IC14 and the LO input by IC10, with both IC's having the same control signals so that they act together like a double-pole switch. The reference is switched by IC9.

IC11 uses the standard dual slope integration method. The voltage applied between IN HI and IN LO is integrated for 100ms onto C49, and then de-integrated using the voltage between REF IN+ and REF IN-. The time taken to de-integrate is a measure of the input voltage.

The result from the AD is...

$$\text{AD reading} = 2048 \times (\text{input voltage/reference voltage})$$

The nominal operating frequency of IC11 is set by R126/R131/R133 & C56/C57 to be 25kHz, in order to give the 100ms integration time. This ensures good rejection of 50/60 Hz ripple. The conversion process is controlled from the micro, using the 'AD\_CE-', 'AD\_RUN' and 'AD\_STATUS' lines. The 'AD\_STATUS' signal is connected to an interrupt pin and indicates when a conversion is complete by a high to low transition. The AD data is read a byte at a time by means of the low- and high-byte controls 'AD\_HBEN-' and 'AD\_LBEN-' from latch IC13 (measurement board sheet 8). Each signal is pulsed low in turn while the data bus is read. 'AD\_CE-' must be at logic 0 during AD reads in order to enable the device.

## **7.2 10-bit Analogue to Digital Converter (UAD)**

(See measurement board sheet 7)

The 10-bit AD on-board the microcontroller (IC27) is used for a multitude of tasks, including self-checks, battery measurement, fuse checks, and reading the rotary switches. There are 8 separate channels available, but this number is expanded up to 22 by using the external multiplexers IC12 & IC18.

The conversion process is carried out under micro control and takes only a few microseconds. The voltage presented to the UAD must be between 0V & 5V.

For a d.c input the reading is given by...

$$\text{AD reading} = 1023 \times (\text{input voltage}/5\text{V})$$

A.c. inputs cannot be measured directly, but must be interpreted by sampling rapidly over an cycle or more and then analyzing the data to find peaks, averages etc.

## **8. Buzzer.**

(See display board sheet 5)

The electromechanical buzzer WD1 requires a square wave drive, which is generated using one of the microcontroller's internal timers. The optimum frequency for the buzzer is 2kHz, which gives the loudest tone and is used on the continuity range. Other frequencies are used for key beeps, warnings, etc.

The microcontroller pin must be buffered to boost the power level. This is done by TR4, configured as an emitter follower. R78/R79/R80 limit the current, and D25 protects TR4 against back-emf from the inductive load of the buzzer drive coil.

## **9. Flash Programming Interface**

(See measurement board sheet 7)

This is a 14-pin DIL interface (PL6, measurement board) which is accessible through a special porthole under the battery cover. It is normally covered by a label.

PL6 allows the following functions...

- Flash programming of the microcontroller.
- Remote control of the instrument by a pc
- Selection of Calibrate, Final Test, or Diagnostics modes.
- RCD test-gear assist.

## **9.1 Flash Programming**

The flash programming interface consists of the 'FLASH\_IN' & 'FLASH\_OUT' signals for data transfer, along with control signals 'RESET-', 'MD2', and 'FWE', plus 0V(D) and 5V. These allow programming from a pc serial port, using appropriate software such as Hitachi Flash Development Toolkit. The RS232 signals from the pc must be level shifted to 5V and inverted in order to be compatible with the MFT interface. To initialize the MFT ready for flash programming, take 'MD2' low, 'FWE' high and then briefly put 'RESET-' low and then high. The system is now ready for programming.

## **9.2 Remote Control**

The instrument is designed so that it can be operated under remote control from a pc RS232 port. All the functions of the front panel can be duplicated, and test results can be transmitted from the instrument, so that it can be automatically calibrated and tested. The remote control interface consists of the 'TX0', 'RX0' and 'BUSY0' signals for data transfer, plus 0V(D) and 5V. These allow basic remote control from a simple terminal programme, and more sophisticated automation by means of custom software. The RS232 signals from the pc must be level shifted to 5V and inverted in order to be compatible with the MFT interface. For further information, see the Appendices.

## **9.3 Selection of Calibrate, Final Test or Diagnostics mode**

It is sometimes useful to lock the instrument into a special mode such as calibrate mode, and this can be done by means of a link between adjacent pins on the interface.

For Calibrate mode, link PL6 pins 1 & 2

For Final Test, link pins 1 & 3.

For Diagnostics, link pins 3 & 5

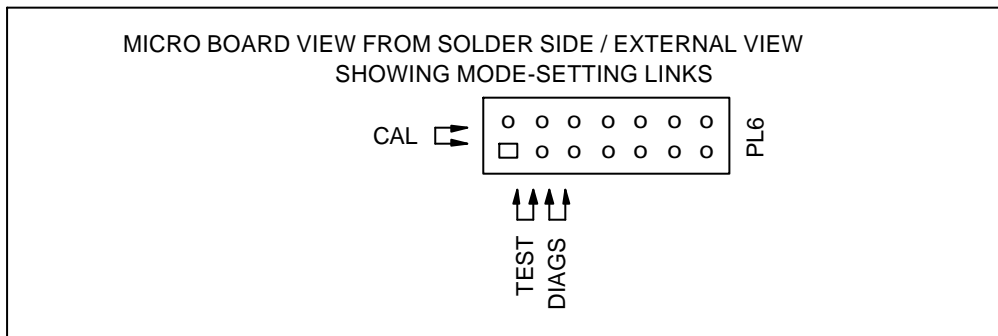

The sketch above shows PL6 as viewed through the MFT battery compartment

For further information, see the Appendices.

## **9.4 RCD Test-gear assist**

The signal ('EXT\_RCD\_TIMER') on PL6 is an output from the microcontroller which is provided so that the instrument test-gear can more easily setup rcd trip times and check currents. This signal is normally high, but goes low when RCD test current starts to flow. This triggers a timer in the test gear which can then simulate a breaker operating after a preset time. The 'EXT\_RCD\_TIMER' signal goes high again 200ms before the theoretical end of the test. This is used to trigger a 'hold' function on the test-gear current measuring circuit, so that the RCD test current can be easily read.



## **10. SPL1000 Probe (MFT1502)**

The instrument part of the probe circuit contains a driving circuit for the probe led, plus a sensing circuit which checks the voltage on the probe tip & and the status of the probe pushbutton. The probe contains the fuse, red/green led and pushbutton circuit, plus a completely isolated torch section.

In order to use a 3-core cable for the probe lead, all the led driving and sensing is done through two wires, leaving the third wire for the live connection

### **10.1 Led driver circuit**

(See relay board sheet 7, and probe switch board)

(See also the supplementary circuit 'Probe Circuit Complete')

The led is driven Green by a +15mA current source circuit. In the instrument part of the circuit, the 'PROBE\_LED\_RED-' and 'PROBE\_LED\_OFF-' signals are high, and 'PROBE\_LED\_GREEN-' is taken low. Thus TR10, TR8 and TR13 are 'off', but TR9 is 'on' and together with R60, R61 and R76, forms a crude current source. The current flows out through R78 and then in the probe through the red/green led D2 and LL4148 diodes D4, D6 & D8, before returning to 0V(A) (see probe switch board). When the led is 'off', a smaller current source of 1mA is used - there must be some current flowing so that the pushbutton can be sensed. 'PROBE\_LED\_RED-' and 'PROBE\_LED\_GREEN-' are high, and 'PROBE\_LED\_OFF-' is low, turning on the 1mA current source circuit TR8/R58/R59/R74/R75. This current flows entirely through R1 in the probe, developing only 1V across the led, which is not enough to turn it on.

To drive the led Red, a negative current is required. 'PROBE\_LED\_GREEN-' and 'PROBE\_LED\_OFF-' are high, and 'PROBE\_LED\_RED-' is low. This turns on TR10, and therefore TR13, which is the -ve current source. This current flows in the probe through D7, D5, D3 and led D2.

The table below shows a summary of the functions of the Probe Controls

	<u>_LED_RED-</u>	<u>_LED_GREEN-</u>	<u>_LED_OFF-</u>
Probe Status			
Led OFF, sense probe voltage	1	1	1
Led OFF	1	1	0
Led RED	0	1	1
Led GREEN	1	0	1

### **10.2 Sensing circuit.**

(See relay board sheet 7, and probe switch & fuse boards)

(See also the supplementary circuit 'Probe Circuit Complete')

The voltage at the top end of the led is monitored by sensing the voltage on the 'PROBE\_OUTPUT' signal. This feeds into amplifier IC8, which has unity gain, and is then level shifted by R64/R65 to produce a voltage suitable for measurement by one of the microcontroller UAD channels. If the probe test button is pressed, the three LL4148 diodes in the current path (see probe switch board) are shorted out, reducing the sensed voltage by about 1.5V. Thus the microcontroller can detect the button press whether the led is red, green, or off. Since constant currents are used, the brightness of the led does not change much when the button is pushed. The sensing circuit can also tell whether or not the SPL1000 Probe is plugged in to the instrument.

To measure the voltage on the probe tip, the current sources are all turned off by setting the control signals high. The voltage which IC8(relay board sheet 7) sees at its input is then just a fraction of the probe tip voltage, as determined by the 10M resistor in the probe (R1 on the probe fuse board) and R55 & R46 in the instrument. This voltage is small enough such that none of the diodes in the probe will conduct. It is measured by the UAD and thus the probe-tip voltage can be calculated.

### **10.3 Blown Fuse detection**

The probe fuse is checked indirectly. On the voltage range, or in pre-test, if there are high volts on the probe tip, but not on the instrument live terminal, then the fuse must be blown. Similarly, during insulation test, if there are high volts on the instrument live, and the probe is plugged in, but no voltage appears on the probe tip, then the fuse is blown.

Note: To assist in fault-finding in the event of a fuse problem, diode D45 (measurement board) can be fitted temporarily. This tells the MFT to bypass all fuse checks.

## **10.4 Torch Section**

(See probe switch board)

(See also the supplementary circuit 'Probe Circuit Complete')

The SPL1000 probe tip is illuminated by a bright white led which is powered from a 9V PP3 battery in the probe body. The led volt-drop is typically 3.6V and resistors R2/R3/R4 limit the current to about 20mA. The torch section is completely electrically isolated from other probe and instrument circuits.

Do not stare into the led while illuminated – it is very bright.

## **11. Miscellaneous**

This section deals with...

- Relay Board Present Check
- Display Board Present Check
- Rotary Switches Present Check
- PLD Check
- Calibration Check

### **11.1 Relay board check**

During the start-up sequence the MFT checks to see if the main Relay board is connected. This is useful, because limited debugging can be carried out without the relay board. If the micro knows that the relay board is missing it can suppress certain errors and bypass some software routines. To detect the presence of the relay board, the microcontroller switches in a light on-board pull-up resistor on the 'RCD\_HIGH\_CURRENT' line. Then it temporarily sets the pin to be an input, and reads back the level. The relay board has a heavier pull-down resistor on this signal, so if the relay board is connected, the signal will read back low, otherwise it is high, in which case a warning is given on the display.

### **11.2 Display board check**

For completeness the MFT also checks to see if the Display board is connected. If the micro knows that the display board is missing it can suppress certain errors. The method of detection is as for the Relay board, but the signal used is 'DISPLAY\_CLOCK'. If the display board is missing, the measurement board relay is briefly rattled.

### **11.3 Rotary Switches check**

During the start-up sequence the MFT checks to see if the Rotary switches are absent. This is so that it can then put itself into a sensible condition to allow limited debugging. The four switch outputs are read, and if they all appear to be set to tapping zero, then it is assumed that the switches are missing, and the instrument locks itself on the Voltage range. The switch condition which is tested for, does not occur during normal use of the instrument.

### **11.4 PLD check**

(See measurement board sheet 3 & 7)

During the start-up sequence the PLD is checked. There are 3 test signals between the microcontroller and the PLD, namely TEST1, TEST2 & TEST3. When the PLD is programmed for the MFT, these pins form an exclusive-or gate with TEST3 being the output. The microcontroller tests all four bit patterns to verify that the ex-or gate is present. If not, a warning is given on the display, and RCD & Loop tests are inhibited.

### **11.5 Calibration check**

At switch-on, the MFT checks its own calibration data to see if it has been set up. If it finds several parameters still at their default values, it assumes that it has not been calibrated and gives the warning 'unc' on the display. (This warning is suppressed in calibrate mode).

## **SECTION 2**

Note: Some supplementary circuit diagrams are available which combine sections from two or more sheets onto a single sheet.

### **1. RCD Test**

The RCD circuit is shared between the microprocessor and relay boards in the MFT. Three functions are provided by the RCD test:

- 1) An adjustable current sink.
- 2) A timer to measure the trip time of an RCD.
- 3) A loop tester.

#### **1.1 RCD Test Sequence**

1. RCD Test Relays are closed
2. The Live Earth voltage and frequency are measured accurately.
3. The digipot is set up for  $\frac{1}{2} I$ . NB In customer mode and final test mode the current is set to 95% of the nominal current for no-trip tests.
4. A single cycle test is done to estimate contact voltage (CV) at  $\frac{1}{2} I$ .
5. If the contact voltage is too high then an error message is flagged ('>50V') and the test stops.
6. An unloaded (no current) multi cycle (8 cycles) loop resistance test is done to measure any in built offsets.
7. A multi cycle (8 cycles) loop resistance test is done at  $\frac{1}{2} I$ .
8. The loop resistance in the circuit is calculated using the loaded and unloaded readings. Using the loop resistance, the contact voltage for the selected current in the actual test (I, 5I,  $\frac{1}{2} I$ ) is predicted – if this is too high then an error message ('>50V') is flagged and the test stops.
9. If the predicted CV is acceptable, then the digipot is set up for the new current required (I, 5I,  $\frac{1}{2} I$ ).
10. If the RCD test is a delayed type (for S-type breakers) then a thirty second count is started – this can be interrupted by pressing the test button.
11. A short delay is introduced to ensure that the PLD sequence starts on the desired rising or falling edge of the mains waveform (0 or 180 degree selection).
12. The interrupts are setup for an timer input capture on the RCD\_I\_MON pin, and timer interrupts on overflow of the input capture timer and also another every 25ms. The overflow provides a means of terminating the test if no trip occurs (after ten overflows each of ~210ms). The 25ms interrupt tests if the last input capture was a regular zero crossing or the RCD tripping. The first zero crossing resets the two timer counters and marks the start of the PLD sequence.
13. On a trip being detected, the relays are turned off and the timer count is used to calculate the RCD trip time. If the RCD doesn't trip then dashes are displayed to show that no trip time is available.

## 1.2 RCD Test Current Control

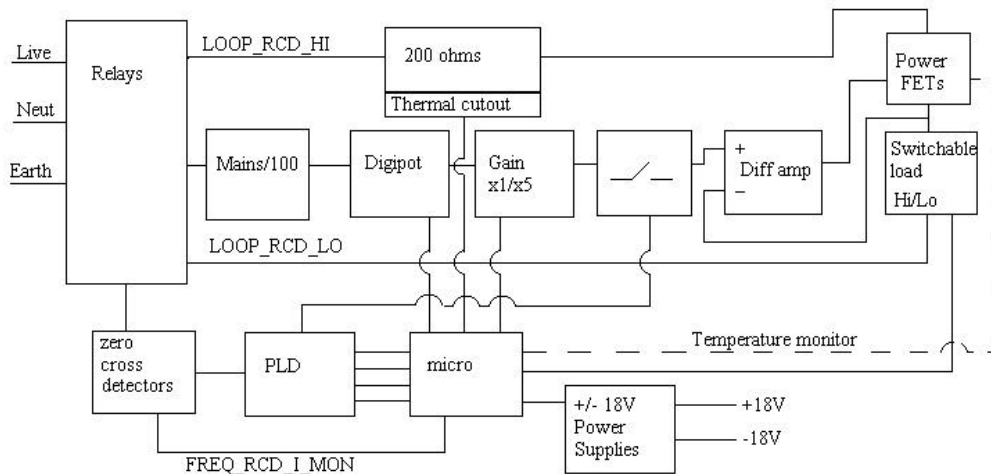

The principle of the circuit is to create a potted down version of the mains waveform which will be equivalent to the voltage generated across a shunt in the RCD current path formed by R18, R25 and R26 (Relay board) when the desired current is flowing. A difference amplifier controls the current flowing to match it to the potted down waveform.

At the start of an RCD test the mains is steered into the RCD circuit by closing RL2, RL3 and RL4. If RL1 is closed then the RCD current would be passed Live-Neutral, but this facility isn't currently used in the MFT. Before closing the relays, the pre-test checks that the maximum safe working voltage of the RCD circuit won't be exceeded (approx. 270V).

The incoming raw mains is attenuated approximately 100 fold by the potential divider formed by R32, R36 and R34 (on Relay board), giving a peak voltage of about 3.4V for 240V mains. This attenuated mains signal is passed onto the micro board where it is buffered in IC22-2. The output of the buffer is fed into the digipot, IC19 - which consists of two cascaded 100kΩ pots under software control. The digipot gives a fine control over the size of the final waveform, allowing for adjustment to the RCD current to take into account the variation of the incoming mains voltage from nominal and also the variety of currents selectable by the user. The microprocessor communicates with the digipot serially.

To add further adjustment a selectable gain stage (x1 or x5) is included (IC23 on micro board). Overall on/off control for the current is provided by IC24-2, which can short the output of the digipot to 0V - this is driven by the PLD (IC28 micro board).

The output of the x1/x5 amplifier is passed back to the Relay board where it is fed to the non-inverting input of IC1-1. The inverting input of the same amplifier is fed with the voltage developed across R18, R25 and R26 (which is proportional to the RCD current). IC1-1 works as a difference amplifier, alternately regulating the current in TR2 or TR1 during positive and negative half cycles respectively. TR3 and TR4 provide a switchable short on R26 to permit the higher RCD currents. Transorb D31 protects TR3/4 drain-source and gate-source junctions in the event of excess voltage. The maximum current available from the mains is limited by the 200 Ω series resistor - R19 (on Relay board).

Pulsating DC currents are produced by blanking off the appropriate positive or negative half cycles of the mains waveform (under interrupt control). A scale factor is applied to the current to achieve the rms current required over a complete mains cycle.

### **1.3 Loop Measurement – RCD current**

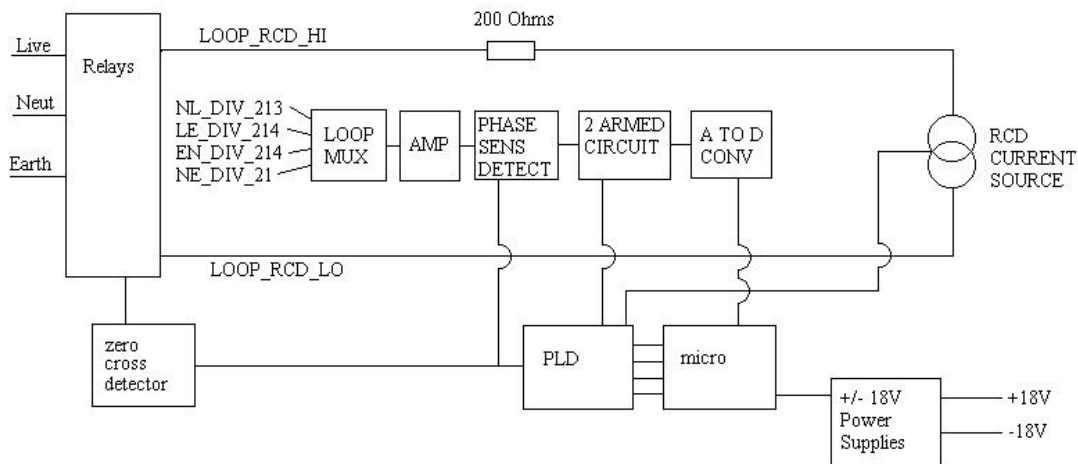

The RCD tests also include a loop resistance measurement, although the measurement is not available for display to the user (it can however be displayed in Final Test Mode – read RCD Final Test Diagnostics for details). It is necessary to know the loop resistance in order to accurately predict the Contact voltage that will be generated when a test current is passed – this contact voltage is the voltage that the Earth would be raised to if the test current was to flow – the statutory limit is 50V. A full description of the operation of the loop measurement circuit is given in the Loop test functional description.

### **1.4 RCD Thermal protection**

IC4 monitors TR1 and TR2 heatsink temperature, if the heatsink becomes too hot the instrument displays the thermometer symbol and will not do any further RCD tests or loop resistance tests that use the RCD current source (i.e. the NO TRIP range and also the 25A or PSSC range when loop resistance is higher than 20  $\Omega$ ). A further thermal trip is located on the 200  $\Omega$  resistor (R19 Relay board), this operates at about 80 °C, typically after several high current RCD tests. The trip itself consists of two trips in series - one is self resetting, the other is a permanent trip (set at a higher temperature). The instrument can detect when these trips have operated using threshold detector IC6-3 (Relay board), but it can only detect the state of the trip when the relays connect the mains to the RCD circuit. The MFT flashes the message ‘Hot’ if the trip on the 2000 resistor has operated.

### **1.5 Power Supplies**

The RCD and Loop circuits use four powers supplies - +5V, -5V, +18V & -18V.

The  $\pm 18V$  supplies are switched off when not in use (to save battery life), being enabled during RCD and Loop tests. The chip which controls the switching on/off of the RCD current (IC24 on the micro board) has its own dedicated +5V supply crudely generated from the +18V supply using zener diode D34. This was required because the chip was feeding power into +18V supply line when it was supplied from the continuous enabled +5V supply.

### **1.6 RCD Final Test Diagnostics**

With the instrument in Final Test Mode some diagnostic information can be called up on the display. By pressing the orange Threshold button after a 1/2I, I, 5IRCD test, the following information can be displayed. Press the button once to step through to each result in turn.

1. Loop resistance
2. Contact voltage
3. Mains frequency (Hz)
4. Default (trip time)

## **1.7 RCD Self Check**

A simple un-calibrated means of checking the RCD currents has been provided by IC1-2 (on relay board). IC1-2 acts as an active rectifier with a gain of 1/2, measuring the voltage across the current feedback formed by R18, R25 & R26. A diagnostics routine has been produced that can measure most of the currents available from the instrument – the 1A current is too large and overranges the AD converter. The zero crossing distortion on low RCD currents limit the usefulness of this feature to a diagnostic aid – it could not be relied on to accurately calibrate the low RCD currents.

## **1.8 RCD Trip timing**

The RCD trip timing relies on the `FREQ_RCD_I_MON` signal which is generated from `LE_DIV_214` within IC9 (on relay board). Signal `FREQ_RCD_I_MON` generates a negative going pulse on each zero crossing of `LE_DIV_214` – it is fed direct to the microprocessor where it is monitored throughout a trip test – if no edge is detected for 25ms then the last edge detected is deemed as being caused by the RCD tripping and the trip time is calculated and displayed accordingly.

## **1.9 Zero crossing detectors**

Two zero crossing detectors are in use on the MFT1501/1502. One is formed by IC6-1 & IC6-2 - this generates the clock for the PLD (in RCD and Loop tests). The first stage of the threshold detector is set to trigger when the mains voltage rises above approximately 20V, when the comparator trips, the feedback adds some hysteresis which shifts the turn off point of the comparator down to 10V. This zero crossing signal can also be switched though to the micro using the Multiplexer IC3-2 (Relay board) – to permit checking for presence of a.c. volts inboard of the 7A fuse FS4.

The second zero cross detector is formed by IC9-1, IC9-2 & IC9-3 – this is used for the timing of RCD trip times. The detector uses two comparators whose thresholds sit at +50mV and –50mV respectively, with each threshold detector providing hysteresis through feedback. The potted down mains signal `LE_DIV_214` is fed into the threshold detectors giving an effective activation voltage of approximately 10V. The digital output `FREQ_RCD_I_MON` is routed to the micro (on both IRQ1 and input capture TIOCA1), where it is used for RCD trip timing and mains frequency measurement.

## **2.0 PLD**

The PLD contains several state machines, which control the current flow and loop measurement circuits during loop and RCD tests. Control lines from the processor initialise the PLD for the specific test required, then, on an instruction from the microprocessor, the PLD runs the sequence without intervention. As the selected sequence finishes `PLD_STATUS` goes low to indicate the fact to the micro.

The PLD is clocked by mains zero crossings, which are debounced by monostables IC30-1 and IC30-2. During RCD trip and no trip tests, the current can flow for a long period of time (up to 2 seconds) – so a watchdog signal is provided from the processor (`LOAD_ON`) to interrupt the current if the microprocessor locks up. Monostable IC31-1 provides the watchdog timer function, disabling the RCD current if the input is not toggled for 20ms or so. Pull downs are provided on the 25A current enable and RCD current enable outputs of the PLD to ensure that noise cannot inadvertently trigger the current when the PLD is not enabled. Three outputs from the PLD are used in parallel to provide extra drive to ensure that the 25A current enable signal (`STROBE_25A`) is strong enough to overcome the 500  $\Omega$  pull down on the relay board. A check has been included in the microprocessor firmware to verify that the PLD has been programmed, using `TEST1`, `TEST2` and `TEST3`. If a fault is detected with the PLD the message 'PLd' will be briefly displayed on the LCD. The PLD has an in circuit programming facility which allows the device to be programmed on the PCB - should the need occur. Connector PL5 can be fitted temporarily to facilitate this, or a temporary connection can be made using spring loaded test pins.

## 2. Loop test

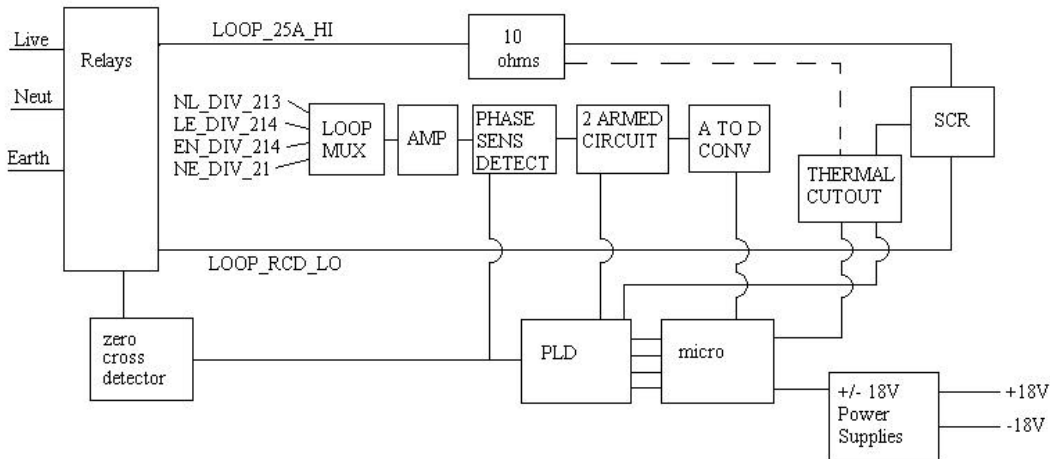

The circuitry of the 25A test is separated into high current and low current parts – the high current parts are to found on the main part of the relay board and the low current parts are on the micro board.

Calling it the 25A test is a bit of misnomer – the actual current is dependant on the voltage applied to the instrument. The test current is defined by the four series 2.4  $\Omega$

resistors (R81-84) that form the load. A SCR (D13) is used to switch the heavy current – the control signal for the SCR coming from the PLD (IC28 – on the micro board). The drive from the PLD is capacitively coupled to the SCR to avoid the possibility of the SCR being left switched under fault conditions. The drive to the SCR is fed through a self resetting thermal cutout mounted on one of the 2.4  $\Omega$

resistors. An open cutout is detected by the threshold detector (IC6-4) which detects when the drive pulse doesn't make it to the SCR. To avoid overheating the PLD applies the load current briefly in the form of two half cycles.

The loop resistance test relies on a measurement of the difference between the loaded and unloaded voltages using the two armed circuit (IC15/17 – micro board).

### 2.1 25A Loop Measurement

The loop resistance measurement is carried out using the same principle as the CM500 and LCB. A measurement is made of the difference between the loaded and unloaded supply voltage is made and this is used to calculate the loop resistance.

For loop resistances under 20 ohms the '25A' loop test applies a 10 ohm load between Live and Earth, but when the loop resistance is higher than 20 ohms the RCD current source is used and the resistance is calculated in a different way. The '25A' Loop measurement is based on the LE\_DIV\_214 channel which comes from the Relay daughter board (IC16). The LE\_DIV\_214 signal passes onto the micro board and is switched into the Phase sensitive detector via multiplexer IC32 (on micro board). The Phase sensitive detector switches between the incoming signal and a negated version (produced by IC25-1) - the switchover occurring on the zero crossings of the mains. The selection of the signal ZERO\_CROSS\_SELECT into IC17-3 (micro board) decides whether the full wave rectified output of the phase sensitive detector is normal or negated. IC25-2 is an amplifier with a gain of 5.7.

The PLD (IC28 on micro board) contains the state machine, which controls the Loop and RCD test sequences and produces the signals which control the so-called two armed circuit. The two armed circuit consists of two balanced RC networks formed by R176/R170/R175/R169/C54 and R171/ R177/ R180/ R179/ R182/C61. The PLD switches the output of IC25-2 such that one capacitor is charged up only on the loaded cycles and the other is charged up on the unloaded cycles. Differential amplifier IC16 (micro board) is not fitted as the differential voltage is measured directly by the 7109 AD converter (via multiplexers IC10 and IC14).

There are a number of resistors in the two armed circuit aren't fitted as they were intended for a future modification of the circuit (R181,R159,R158,R147). Also R141 is not fitted as this was required only when IC16 (AD622) was fitted.

## 2.2 No Trip Loop test

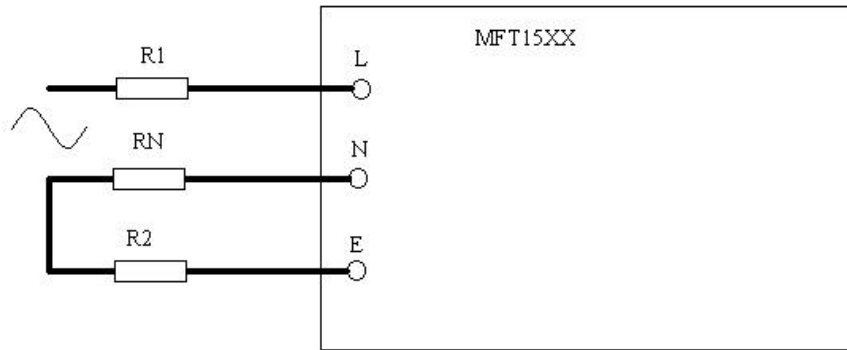

The 'NO TRIP' loop measurement is a three-wire measurement similar to that used in the LCB and CM500. It works in a different way to the '25A' test, calculating the resistance in each of the three supply leads in turn, then producing the Live Earth loop resistance from these components.

The sequence of tests is as follows:

1. The voltage  $V_{LE}$  and frequency are measured accurately using the LE\_DIV\_214 signal (IC16-2 Relay board). LE\_DIV\_214 is switched through to the 12-bit AD converter (IC11 micro board) via the Volts mux (IC3-1 Relay board).
  2. If the voltage measured is less than 300V the test proceeds, otherwise an error is flagged (as the RCD circuit can only withstand single phase volts).
  3. A 15mA RCD style two wire loop test (only 0.1 ohm resolution) is carried out (refer to RCD test sequence) – if the loop result is over 40 ohms the result is declared as final and the test exits displaying the result.
  4. If the result is under 40 ohms the relays are setup for 25A loop current flowing between Live and Neutral.
  5. A check is done to ensure that Live-Neutral volts are present by checking for edges on the zero cross detectors serving Live and Fused live (refer to the section 'Zero crossing detectors')
  6. If no edges were detected at the Fused Live input this is interpreted as there being no Neutral connection present – the zero cross detector at Live is more sensitive and can often continue to detect edges due to leakage current paths in the instrument between Earth and Neutral.
  7. An accurate measurement is made of the LN volts using the LN volts channel – this is redundant as a measurement of the volts is made later (using the LE channel) and this one is used in the calculation of the LN loop resistance. The LE channel does in fact measure LN volts when the relays are configured for current through Neutral instead of Earth.
  8.  $V_d$  is the output of the two armed circuit. An unloaded 25A test is carried out on the PLD. When that finishes, the unloaded value of  $V_d$  is measured while using the LE channel (it's LN really).
  9. The loaded  $V_d$  is measured using the LE\_DIV\_214 channel again.
  10. The Live Neutral loop resistance is calculated using both loaded and unloaded values of  $V_d$ .
  11. The unloaded value of  $V_d$  is measured using the NE\_DIV\_214 channel (IC12-2 Relay board).
  12. The 25A loaded test is repeated and the value of  $V_d$  is measured again using the NE\_DIV\_214 channel.
  13. The value of  $R_N$  is calculated from the NE measurement and from this value of  $R_L$  is calculated by deducting  $R_N$  from the LN ( $R_L + R_N$ ) loop value calculated earlier.
  14. The digipot is set up for 15mA. The relays are changed again to pass current through the RCD circuit, this time the current is steered Live Earth. The AD converter is steered to look at the high sensitivity NE\_DIV\_21 channel (IC11 Relay board).
  15. The shortened multicycle sequence is used on the PLD alternately passing current in forward and reversed directions to cancel out any offsets in the measurement circuit. Arrays of forward and reversed results are built up, then an algorithm sorts the forward and reversed data separately rejecting values that are too far from the mean.
- When a sufficient number of sufficiently closely grouped results have been obtained the Earth resistance ( $R_2$ ) is calculated using the combined forward and reverse data.
- NB The criteria for accepting results is lowered as the number of tests done increases to ensure that the instrument reaches a result. If the instrument is having trouble getting consistent result the noise flag is switched on.
16. The combined earth loop resistance is calculated by adding  $R_1$  and  $R_2$  together.



### **2.3 No Trip Loop Final Test Diagnostics**

The three components of the No trip loop test can be displayed in Final test mode by pressing the orange Threshold button. The  $R_1$  component is indicated by the  $R_P$  symbol, the  $R_2$  component is indicated by the  $R_C$  symbol and the  $R_N$  component is indicated by both  $R_P$  and  $R_C$  symbols being lit.

### **3. Off Switch Position**

#### **3.1 Brief Description**

The power supply is turned 'on' by the hardware when the rotary switch is turned away from the 'OFF' position, but cannot be turned 'off' directly by the hardware in the same way when the 'OFF' position is selected. It can only be turned 'off' under micro control.

#### **3.2 Details**

The rotary switches are read by the microcontroller every 400ms, but it takes no action the first time that it senses the 'OFF' position. In other words, 'OFF' must be selected for more than 400ms before anything happens. This is convenient because if the switch is turned quickly through 'OFF', the MFT does not need to power-down and then power-up again and go through its start-up sequence.

When switching the MFT 'off', the micro de-energizes the relays in a controlled sequence, does a few other bits of housekeeping, and then sets the 'INSTRUMENT\_OFF' signal to a high level (measurement board sheet 11). This causes TR15 to turn on, thereby pulling down '5V\_ON' and shutting down all the power. There is no difference in behaviour between what happens in the 'OFF' position, and what happens during 'autosutdown'.

For more details see the section on the Power 'on/off' circuit.

A few items remain powered up directly from the battery.

- HV inverter transformer (measurement board sheet 1)
- Battery check circuit (measurement board sheet 10)
- 'Lock' button (measurement board sheet 10)
- Power on/off switching circuit (measurement board sheet 11)
- 5V supply generator, IC3 (measurement board sheet 11)
- 18V supplies switch, TR2 (measurement board sheet 11)
- Display Backlight (display board sheet 2)

None of these circuits should draw much power and the total 'OFF' current consumption should be  $<75\mu\text{A}$ .

If the 'lock' button is pressed while the switch is in the 'OFF' position, the instrument powers-up, but then immediately powers-down again. This should be invisible to the user. If the 'test' button is pressed as well as the 'lock' button, the instrument briefly displays the battery voltage before switching off.

## 4. Voltage Measurement

(See relay board sheets 2 & 4, and the supplementary circuit 'Voltmeter Relay Board Circuits' which combines these 2 sheets)(See also measurement board sheet 6)

### 4.1 Brief Description

Each pair of terminals L-E, N-E, & L-N, has its own amplifier which divides the relevant input voltage by a factor of about 200. See IC12 & IC16 on the relay daughter board (sheet 2). During all voltage measurements, all the relays are de-energised, and the Earth terminal of the instrument is connected to 0V(A). Thus the L-E and N-E amplifiers are simple dividers referred to 0V or LO\_V, (which is actually also at 0V potential during voltage measurement). However, the L-N measurement requires a differential amplifier, see IC12-1. The signals required for voltage measurement are outputs 'LE\_DIV\_214', 'NL\_DIV\_213' & 'NE\_DIV\_214' and their level-shifted counterparts 'UAD\_LE', 'UAD\_NL', and 'UAD\_NE'.

The signals which come direct from the amplifiers are routed through a multiplexer (IC3-1, sheet 4) to a precision rectifier consisting of IC2 and its associated components. The output of IC2-2 is a positive-going full-wave rectified signal which connects to the 7109 AD converter (measurement board sheet 6). The voltage here is measured using a 1V reference, and gives a measure of the magnitude of the incoming a.c.

The level shifted UAD signals from IC12 & IC16 are not rectified but are 50Hz a.c. and are read in a few microseconds, so it is necessary to take many samples over a period of time and interpret the results to deduce the size of the input waveform.

Voltage measurement during pre-test employs a slightly different way of using the measurement signals than voltage measurement in the dedicated switch position.

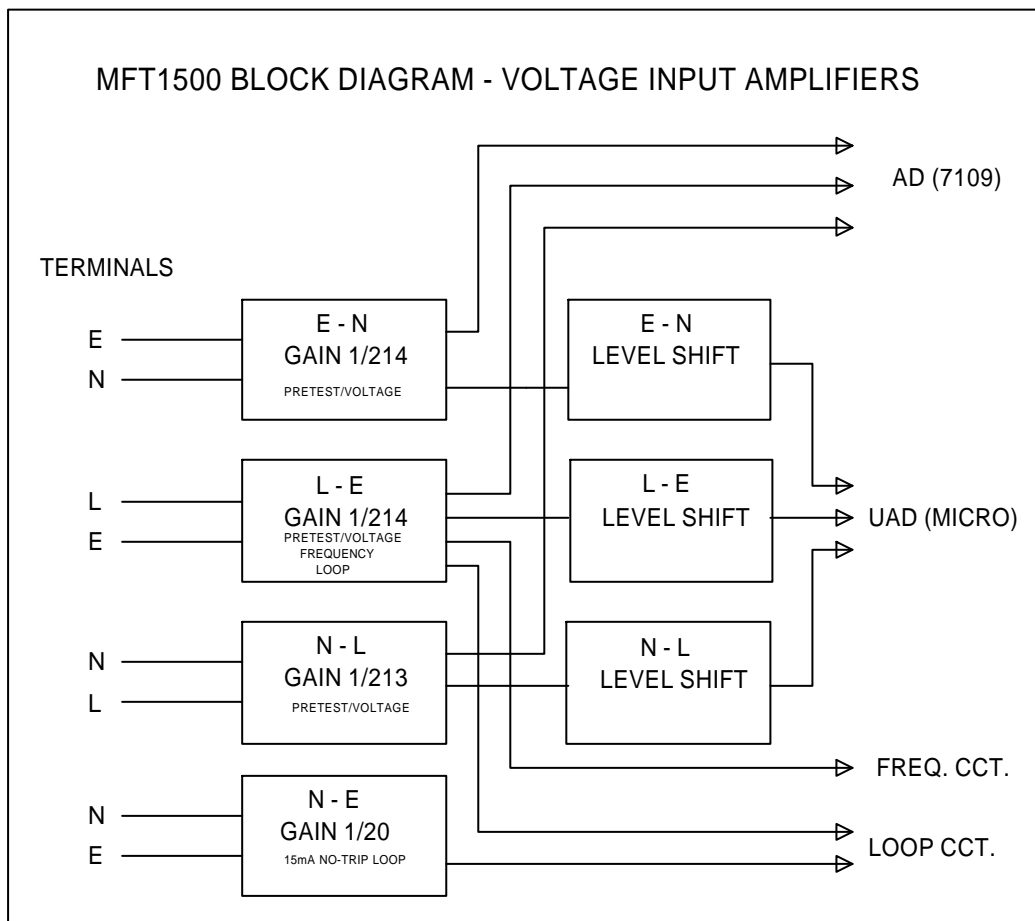

## **4.2 Voltage Switch Position.**

All three voltages L-E, L-N & N-E are measured approximately using the 'UAD\_LE', 'UAD\_NL' & 'UAD\_NE' signals and the readings are used to control the 'neons' on the display. The L-E voltage is also measured accurately using the 7109. The multiplexer IC3 (relay board sheet 4) is permanently set to select the 'LE\_DIV\_214' signal for IC2, and the rectified output is measured by the 7109, using a 1V reference signal. The MFT normally displays the L-E voltage of the system being tested, but if it detects a larger voltage on L-N or N-E, then it shows this voltage instead, using the less accurate readings.

The display flashes to show that the reading is not to full specification.

The instrument can measure d.c voltage, but the precision output from the rectifier is always positive, and so the polarity of the input must be deduced from the UAD readings. This is only reliable for inputs greater than about 20V and so the sign on the display is suppressed below this level.

## **4.3 Pre-test.**

All of the input voltages are measured approximately using the signal 'UAD\_VOLTS\_IN\_HI' which is derived from the output of the precision rectifier (relay board sheet 4). This results in a shorter measurement time than when using the 7109, and gives good enough results for pre-test. The multiplexer IC3-1 (relay board sheet 4) selects the three signals 'NL\_DIV\_213', 'LE\_DIV\_214', and 'NE\_DIV\_214' in a repeating sequence for about 25ms each, during which time the waveform at the output of IC2 ('UAD\_VOLTS\_IN\_HI') is rapidly sampled by the UAD to find the peak of the waveform. This information is used to calculate the displayed voltage reading and to control the 'neons'. The instrument shows the largest voltage that it finds on the terminals. Since pre-test readings use a peak-detection method, these may disagree slightly with results on the Voltage range, which use a mean-sensing method.

## **4.4 Blown Fuse detection.**

Correct voltage measurement relies on the 1A fuse (FS2, relay board sheet 1) being intact, so it is necessary to perform regular fuse checks. Normally the Earth terminal of the instrument is tied to 0V(A) through this fuse and through resistors R111 & R114 in the ohms reference circuit (measurement board sheet 2). If the 1A is blown and voltage is being measured, then the potential on the instrument Earth terminal will rise. This is monitored using the 'UAD\_EN' signal derived from IC16-1 (relay daughter board, sheet 2). If a voltage greater than about 30V is detected on the Earth terminal, it is assumed that the fuse has blown.

Note: To assist in fault-finding in the event of a fuse problem, diode D45 (measurement board) can be fitted temporarily. This tells the MFT to bypass all fuse checks.

## **4.5 Frequency Measurement**

The supply frequency must be known for the Loop test calculations.

The frequency which is measured is that of the Live-Earth voltage. Amplifier IC16-2 on the relay daughter board (sheet 2) divides down the terminal voltage to give a small a.c. signal on 'LE\_DIV\_214' which is routed to a window comparator IC9-1 and IC9-2 and associated components (relay board sheet 4). The comparator has +/-50mV nominal thresholds on its inputs, set by resistor chain R86/R87/R89/R91. When the incoming waveform goes outside of this window, the comparator output (pins 1 & 2) goes to -5V. Quiescent output is +5V. This is then inverted & cleaned up by a follow-on comparator IC9-3. The output from pin 14 is clamped to normal logic levels to become signal 'FREQ\_RCD\_I\_MON', which takes the form of a train of narrow pulses of height 5V, at twice the input frequency. For 230V 50Hz input, these pulses have a width of about 175us. The 'FREQ\_RCD\_I\_MON' signal connects to a microcontroller interrupt pin (measurement board sheet 7). The micro times a whole number of cycles for about 180ms and calculates the frequency from the data.

## **5. Ohms Measurement**

### **5.1 Brief Description**

The circuit sits in a high impedance condition, with all the high voltage relays de-energized, until ‘contact’ has been detected, i.e. less than about 150kohms has been connected between the Live and Earth terminals.

When contact has been detected, relay RL3 (relay board sheet 1) is energized and the terminals are connected to a low impedance source. Test current flows from the measurement board voltage source (measurement board sheet 2), through RL1 & D23, then via the 500mA fuse and various connectors to the relay daughter board, and eventually to the +ve (Live) terminal. Return current path is back on the relay board through RL1, RL2 and the 1A fuse, all the way over to the measurement daughter board, and back through the other half of RL1 (measurement board sheet 2) to 0V(A). The reference voltage for the 12-bit AD is picked off here, at the measurement board relay. The input voltage at the terminals is measured on the relay daughter board by amplifier IC15 and its associated components (relay board sheet 3). If the measured resistance is larger than about 250k, the ohms circuit reverts to its original ‘contact detect’ configuration.

### **5.2 Contact detect circuit**

(See relay board sheet 3, also sheet 1)

(See also the supplementary circuit ‘Ohms/Buzzer Relay Board Circuits, Input Amplifier & Relays’)

The contact detect circuit is mostly on the relay daughter board, and consists of IC15 and its associated components (sheet 3). For ohms and kilohms measurement, the signal ‘KOHMS\_OHMS’ is high, which opens the analog switches IC13-3 & IC14-3, resulting in a gain of -0.47 for IC15-1. The output of IC15-1 (pin 1) is then level shifted by R121/R130/R129 and routed to one of the UAD channels as ‘UAD\_CONTACT\_DETECT’. Thus the microcontroller is able to quickly determine the voltage between the Live & Earth terminals. A small current is available at the Live terminal through IC14-2 since the ‘CONTACT\_DETECT’ signal is high. This current path is from +5V, through IC14-2 to the ‘DISCHARGE\_LO’ signal (relay board sheet 3) and then through R106/R114/R108 (relay board sheet 1) to the output terminal. As the test resistance changes, so does the voltage fed to the UAD on ‘UAD\_CONTACT\_DETECT’, and we can detect when the load drops below about 150kohms.

### **5.3 Ohms & Kohms Source & Reference Circuits**

(See measurement board sheet 2)

(See also the supplementary circuit ‘Ohms/Buzzer Measurement Board Circuits, Voltage Source and Reference’)

For ohms measurement up to 100ohms, the measurement board relay RL1 is de-energized and the test current flows out from +5V via R100-103, RL1 and D23. The test current eventually returns via the other half of RL1 and the reference resistors R111/R114 into 0V(A). For resistances >100ohms, the relay RL1 is energized, and ‘KOHMS\_SOURCE\_ON’ is set high, giving a reduced source voltage of about 2.5V through TR23. Now the return current flows through R107 and one of the parallel paths R109, R110, or R113 depending on the range setting. Note that the relay control line ‘MOHMS\_KOHMS\_RELAY’ is from latch IC10 on the *relay* board, where it is incorrectly named as ‘OHMS\_RELAY’. The signal ‘KOHMS\_SOURCE\_ON’ also originates from the same latch

The range selection system for the kohms ranges uses the signals ‘MOHMS\_KOHMS\_HI\_RANGE’, ‘MOHMS\_KOHMS\_MID\_RANGE’ & ‘MOHMS\_KOHMS\_LO\_RANGE’ from latch IC7 (measurement board sheet 7) to control fets TR20-22. See the table below.

## Kilohms ranging Table

	'_LO_RANGE' (TR22)	'_MID_RANGE' (TR21)	'_HI_RANGE' (TR20)
<b>Resistance Range</b>			
<b>100? - 1k?</b>	<b>1</b>	<b>0</b>	<b>0</b>
<b>1k? – 10k?</b>	<b>0</b>	<b>1</b>	<b>0</b>
<b>10k? – 100k?</b>	<b>0</b>	<b>0</b>	<b>1</b>
<b>&gt;100k?</b>	<b>0</b>	<b>0</b>	<b>0</b>

Note: Ohms ranging between 10ohm & 100ohm ranges takes place in the input circuit on the relay board.

'MOHMS\_KOHMS\_FILTER\_ON' controls a capacitor filter via TR19, which is normally 'on' during ohms and kohms measurements.

The '>100k' setting referred to in the table is not used for measurement as such, but allows the instrument to determine if the resistance is more than about 250kohms. If so, then all relays are de-energized and the circuit reverts to the contact detect configuration. The voltage developed across the reference resistance is buffered by amplifier IC8 to become signal 'AD\_MOHMS\_OHMS\_REF\_HI', which is used as the reference on the 'ohms' ranges (<100ohms). On 'kilohms' ranges (>100ohms), this is divided down by R55, R65 & R66 to provide a smaller reference 'AD\_KOHMS\_REF\_LO'. Both signals are routed to the 7109 AD converter via the multiplexer IC9 (measurement board sheet 6).

### **5.4 Ohms & Kohms Input circuit.**

(See relay board sheet 3)

(See also the supplementary circuit 'Ohms/Buzzer Relay Board Circuits, Input Amplifier & Relays')

This is on the relay daughter board, and consists of differential amplifier IC15 and its associated components. For ohms and kilohms measurement, the signal 'KOHMS\_OHMS' is high, which opens the analogue switches IC13-3 & IC14-3, resulting in a gain of -0.47 for IC15-1. The output of IC15-1 is a measure of the voltage between the Live & Earth terminals and therefore across the resistance being measured. Note that it is not referred to 0V, but to 'LO\_V', which is the voltage at the top of the reference resistor in the measurement board part of the circuit. This is almost the same as the voltage on the Earth terminal, differing only by the volt drop across the fuses and the wiring. The purpose of this is to lessen the common-mode voltage at IC15's inputs. This reduces the errors, improves linearity, and helps the guarding. There are two ohms measurement ranges, and range selection uses IC13-2, controlled by the signal 'OHMS\_HI\_RANGE'. For measurement up to 10ohms, this signal is low, and the full output of IC15-1 is selected by IC13-2 as the measurement signal 'AD\_KOHMS\_OHMS\_IN\_HI'. For resistances between 10ohms & 100ohms, 'OHMS\_HI\_RANGE' is taken to logic 1, and a divided-down output from IC15-1 is selected by IC13-2. The signal, 'AD\_KOHMS\_OHMS\_IN\_HI', is routed to the input of the 7109 through multiplexer IC14 (measurement board sheet 6).

The AD reading is then given by

$$\begin{aligned}
 \text{AD reading} &= 2048 \times (\text{7109 input voltage} / \text{7109 reference voltage}) \\
 &= 2048 \times (\text{k1} \times \text{terminal voltage}) / (\text{k2} \times \text{test current}) \\
 &= 2048 \times \text{k1/k2} \times \text{test resistance} \\
 &\text{where k1 \& k2 are constants.}
 \end{aligned}$$

The microcontroller is programmed with knowledge of the values of k1 & k2, and can calculate the measured resistance from the AD reading.

## **5.5 Blown fuse detection**

The 500mA fuse (FS1, relay board sheet 1) is checked indirectly by making quick measurements of the current and the terminal voltage, and checking for readings incompatible with normal operation. The input voltage can be sensed by the UAD using the 'UAD\_CONTACT\_DETECT' signal from the input circuit on the relay board (sheet 3). The current can be monitored using 'UAD\_LO\_V' which is the buffered reference voltage on the measurement board (sheet 2). If the reference is less than about 50mV and 'UAD\_CONTACT\_DETECT' is greater than about 1V, then it is assumed that the fuse is blown. The signal 'UAD\_OHMS\_FUSE\_CHECK' is not actually used.

Note: To assist fault-finding in the event of a fuse problem, diode D45 (measurement board) can be fitted temporarily. This tells the MFT to bypass all fuse checks.

## **6. Buzzer Range**

### **6.1 Brief Description**

Operation is very similar to that of the ohms function.

The circuit sits in a high impedance configuration, with all the high voltage relays de-energized, until 'contact' has been detected. Then relay RL3 (relay board sheet 1) is energized and the terminals are connected to the ohms voltage source circuit. Test current now flows exactly as for ohms. All measurements on the buzzer range are made using the UAD, and the 7109 is not used at all. The terminal voltage and the current are sensed using 'UAD\_CONTACT\_DETECT' and 'UAD\_LO\_V' signals. If the measured resistance is larger than about 250k, the buzzer circuit reverts to its original 'contact detect' configuration.

### **6.2 Contact detect circuit**

This operates exactly as for ohms. The cut-in detection threshold is approximately 150kohms.

### **6.3 Buzzer Range Operation**

The normal ohms/kohms circuits are used, but the decision to turn the buzzer 'on' or 'off' is always made on the 'ohms' range - i.e. with the measurement board relay de-energized. The test current returns from the -ve terminal through RL1 and R111/R114 (measurement board sheet 2). The voltage developed across these resistors is buffered by IC8, and after passing through a protection circuit (R49/R78/D18) this becomes the signal 'UAD\_LO\_V' which connects to one of the on-board AD channels on the microcontroller. This voltage can be measured in a few microseconds and gives an indication of the size of the test current and therefore of the test resistance. The micro is programmed with knowledge of the circuit constants, and it can calculate if the unknown resistance is more or less than the threshold set by the user. The buzzer is then controlled accordingly. If the test resistance is greater than about 300ohms, the MFT switches over to the kilohms circuit so that it can measure higher values (i.e. the measurement board relay RL1 is energized). If the load is then found to be greater than about 250kohms, all relays are de-energized and the circuit reverts to the contact detect configuration.

For a description of the buzzer drive circuit, see the Buzzer section elsewhere in this document.

### **6.3 Blown fuse detection**

The 500mA fuse is checked by the same method as described for ohms measurement

Note: To assist fault-finding in the event of a fuse problem, diode D45 (measurement board) can be fitted temporarily. This tells the MFT to bypass all fuse checks.

## **7. Insulation Test**

(See measurement board sheets 1 & 2)

(See also the supplementary circuit 'Insulation Measurement Board Circuits, HV Inverter, Input & Reference')

### **7.1 Brief Description**

When the 'test' button is pressed to initiate an insulation test, 'MOHMS\_HV\_ON' signal (measurement board sheet 1) is taken to logic 1, turning on the hv inverter. A high voltage is produced, which is routed all the way across to the relay daughter board. 'L\_RELAY' is set high to energize relay RL3 (relay board sheet 1), and so the test voltage gets connected to the +ve (Live) terminal. The test current flows through the test specimen into the -ve (Earth) terminal and returns all the way back to the measurement daughter board. Since RL1 is energized, (measurement board sheet 2) the test current will flow through one or more of the reference resistors R107/R109/R110/R113 (sheet 2) to 0V(A). The reference voltage produced across these is buffered by a low offset amplifier (IC8 , sheet 2) and then fed to the 7109 AD converter (measurement board sheet 6). The input for the 7109 is a fixed fraction of the output voltage, taken from the bottom end of R69 in the inverter circuit (sheet 1). The result from the 7109 is then a direct measure of the resistance under test. When the test is stopped by releasing the 'test' button, the hv is turned off, and all relays are de-energized. Any stored energy on a capacitive test load is quickly discharged through the discharge resistors R106, R108, & R114 (relay board sheet1) and IC14-2 (relay board sheet 3). This returns to 0V, since the signal 'CONTACT\_DETECT' is low for insulation tests.

### **7.2 HV Inverter**

(See measurement board sheet 1)

The essential parts of the inverter circuit are...

- Transformer & FET
- Reference
- Feedback
- Output Voltage Selection
- Oscillator
- Current limit
- Control circuit

#### **7.2.1 Transformer and FET**

(See measurement board sheet 1)

Energy is stored in the core of transformer TX1 while fet switch TR8 is 'on', and then transferred into the secondary circuit when TR8 is turned 'off'. The rectifying effect of diodes D20 and D25 causes a positive voltage to be produced on capacitor C44. Power is continuously transferred from primary to secondary of TX1 by providing a pulse train on the gate of TR8. The amount of power transfer, and therefore the magnitude of C44's voltage, is varied by changing the mark/space ratio of the pulse train.

#### **7.2.2 Reference**

The 2.5V level produced by bandgap reference D29 (measurement board sheet 6), is divided down by R51/R62 & R18/R26 (sheet 1) to provide a 2.0V reference at IC4 pin 6.

#### **7.2.3 Feedback**

(See measurement board sheet 1)

A proportion of the output of voltage on C44 is fed back to IC4 pin 5 through R90 & R72. When the inverter has settled and is producing a stable output, the voltage at this point should match the reference level (2V approx.) set up on pin 6. A sub-fraction of this voltage is used as the input signal for the 12-bit a/d converter ('AD\_MOHMS\_IN\_HI').



## **7.2.4 Output Voltage Selection**

(See measurement board sheet 1)

There is a divider on the inverter output, which consists of the upper part, R90 & R72, and the lower part, from IC4 pin 5 to 0V. The resistance of this section determines the output voltage, according to the conditions of the fets TR14, TR16 and TR17. These are controlled by three control lines, 'MOHMS\_250V', 'MOHMS\_500V', and 'MOHMS\_1000V', from latch IC7 (sheet 8). See the table below.

Insulation Test output voltage selection.

	MOHMS_250V' (TR14)	MOHMS_500V' (TR16)	MOHMS_1000V' (TR17)
Output Setting			
25V	0	0	0
250V	1	0	0
500V	0	1	0
1000V	0	0	1

## **7.2.5 Oscillator**

(See measurement board sheet 1)

The basic oscillator consists of comparator IC5-2, plus C25, and R54/R63/R53/R52. This produces a sawtooth wave on C25, a 5V square wave on IC5 pin 1, and a 2.5V square wave on pin 14. There is a discharge path for C25 via R52/R53/R63 into pin 1 when pin 1 is low, but there is also another path through TR9 and R48 into IC5 pin 14. It is this (variable) path which allows control over the mark/space ratio at TR8 gate. Note that comparator IC5 has 'open collector' outputs.

## **7.2.6 Current Limit**

(See measurement board sheet 1)

Return current into the lower end of TX1 secondary must flow in via resistors R27/R28/R29, and this pulls TR5 emitter downwards in potential according to how much current is flowing. If the output current from the inverter is gradually increased, there comes a point when eventually TR5 emitter will be pulled below its base (i.e. to about -0.5V) and TR5 will turn 'on', squashing the 2V reference on IC4 pin 6, and therefore reducing the output voltage to zero. This control mechanism allows the inverter to deliver 1mA at its rated voltage but less than 2mA into a short circuit. In fact the short circuit current is not pure d.c, but has an a.c. component, due to response-time limitations in the current control loop.

## **7.2.7 Control Circuit**

(See measurement board sheet 1)

A fraction of the output voltage, as described in the 'feedback' section, is compared to the 2.0V reference by IC4-2 (error amplifier), producing an error signal on pin 7. This signal modifies the behaviour of the oscillator, allowing the 'on' time of fet TR8 to be changed, as described earlier in the 'oscillator' section. The 'off' time does not change. The overall circuit feedback is negative, thereby resulting in a stable controlled output voltage on C44. When the inverter has settled, the voltages on IC4 pins 5 & 6 should be equal (approximately 2.0V if the inverter is lightly loaded). The master control of the hv circuit is 'MOHMS\_HV\_ON'. This is inverted and level shifted up to battery voltage by IC5-4. If 'MOHMS\_HV ON' is taken high by the microcontroller, R25 gets connected through TR3 to 'BATTERY\_+VE' and acts as a pull-up resistor for IC5 pin 2. Without this, (if 'HV ON' is low), there can be no drive to TR8 gate, since IC5 has an open-collector output.

### **7.3 Insulation test voltage measurement**

(See also the supplementary circuit ‘Insulation Measurement Board Circuits, HV Inverter & Measurement’)

On any given insulation test voltage setting, the signal at IC4 pin 5 (measurement board sheet 1) is always a fixed proportion of the output voltage. A tapping off this point (‘AD\_MOHMS\_IN\_HI’), is routed through IC14 (measurement board sheet 6) and used as the input signal for the 12-bit a/d converter IC11 (sheet 6). The microcontroller knows the status of the control switches TR14, TR16 & TR17, and therefore always knows what fraction of the inverter output voltage is present on ‘AD\_MOHMS\_IN\_HI’.

### **7.4 Insulation test current measurement**

(See also the supplementary circuit ‘Insulation Measurement Board Circuits, HV Inverter & Measurement’)

The test current to be measured, flows into the –ve (Earth) terminal of the instrument, to the relay daughter board section, then through FS3, and relays RL1 & RL2 (both de-energized) and FS2 (relay board sheet 1). Then it crosses over to the measurement board and finally ends up on the measurement board daughter section. Here, flow is along ‘INS\_CONT\_LO’ and through the (energized) relay RL1 into R107 (sheet 2). The voltage across R107 provides a measure of the current. A large spread of currents must be measured, and so a means of current ranging is provided. Extra resistors R109, R110, or R113 can be switched in parallel with R107, by means of the fets TR20-22. These are under the control of signals ‘MOHMS\_KOHMS\_LO\_RANGE’, ‘MOHMS\_KOHMS\_MID\_RANGE’, & ‘MOHMS\_KOHMS\_HI\_RANGE’ from latch IC7 (measurement board sheet 8). The point at which range changes occur depends on when the AD converter over-ranges, which is hard to define in terms of resistance, and also depends on which test voltage has been selected. The table below gives a rough guide.

	‘_LO_RANGE’ (TR22)	‘_MID_RANGE’ (TR21)	‘_HI_RANGE’ (TR20)
Measurement range			
0? - 100’s k?	1	0	0
100’s k? – M?’ s	0	1	0
M?’ s – 100’s M?	0	0	1
100’s M? on	0	0	0

‘MOHMS\_KOHMS\_FILTER\_ON’ controls a capacitor filter via TR19, which is normally ‘on’ during insulation test.

The reference voltage developed by across R107 is buffered by the microvolt-offset amplifier IC8 and fed to the AD converter reference via the multiplexer IC9 (sheet 6).

The AD reading is given by

$$\begin{aligned}
 \text{AD reading} &= 2048 \times (7109 \text{ input voltage} / 7109 \text{ reference voltage}) \\
 &= 2048 \times (k1 \times \text{terminal voltage}) / (k2 \times \text{test current}) \\
 &= 2048 \times k1/k2 \times \text{test resistance} \\
 &\text{where } k1 \text{ \& } k2 \text{ are constants.}
 \end{aligned}$$

The microcontroller is programmed with knowledge of the values of k1 & k2, and can calculate the measured resistance from the AD reading.

## **7.5 Blown fuse detection**

The 500mA fuse (FS1, relay board sheet 1) is checked indirectly by making quick measurements of the test current and the terminal voltage, and checking for readings incompatible with normal operation. If only a small current is flowing (say <100uA), then the hv inverter is not heavily loaded, and should be outputting approximately its rated test voltage. The micro measures the current using the signal 'UAD\_LO\_V', which is the buffered reference voltage, and measures the terminal voltage by means of the input amplifier signals from the relay board, (just as for normal voltage measurement). If there is a small current flowing, and only a small output voltage, then it is assumed that the 500mA fuse has blown (FS1, relay board sheet 1).

Note: To assist in fault-finding in the event of a fuse problem, diode D45 (measurement board) can be fitted temporarily. This tells the MFT to bypass all fuse checks.

## **Appendices**



# Appendix 1 Supplementary Circuit Diagrams

## 1. Insulation Meas Board CCT's , HV Inverter & Measurement

### INSULATION MEAS BOARD CIRCUITS HV INVERTER & MEASUREMENT

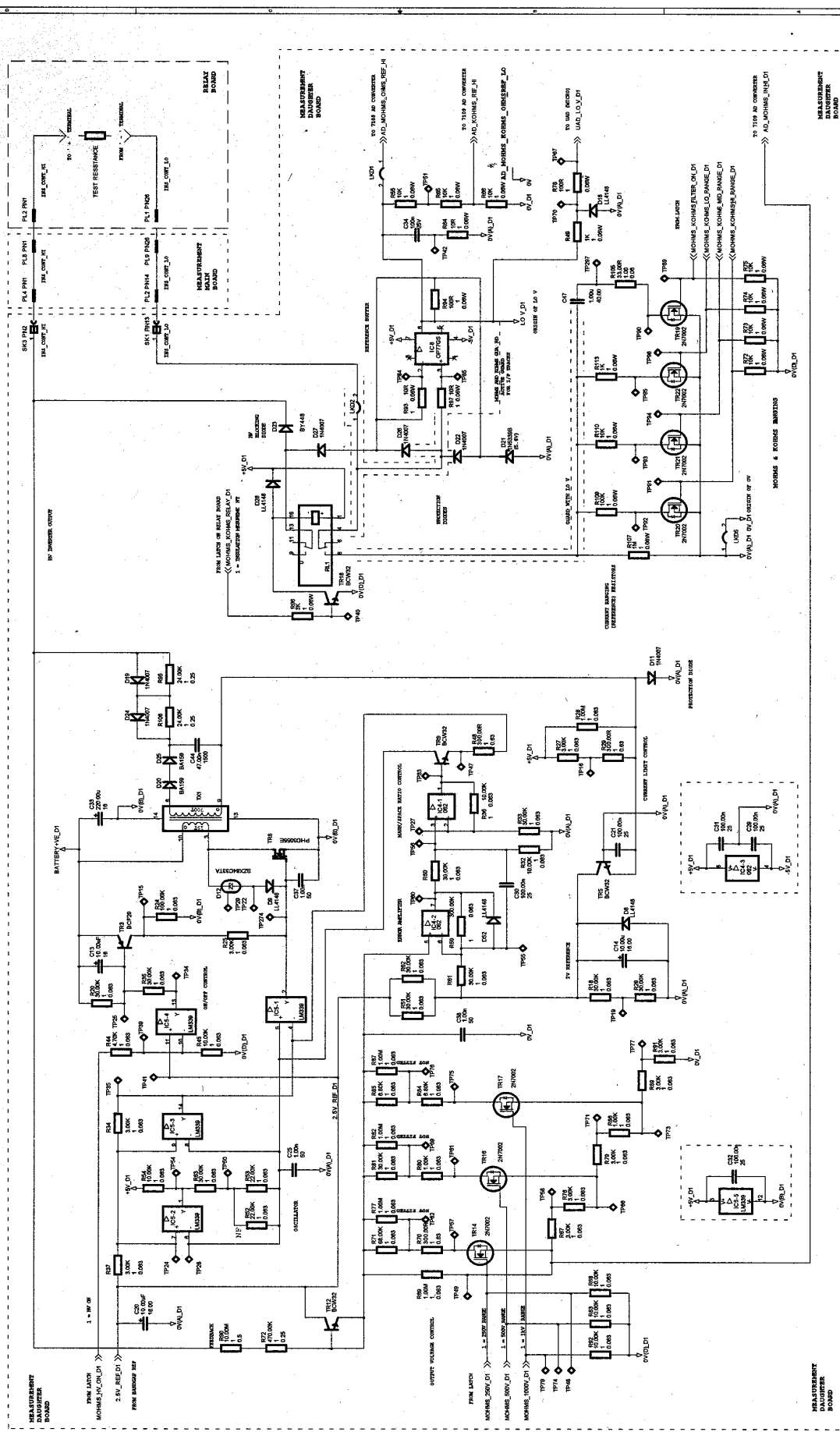

Megger		INSULATION TEST CIRCUIT	
REV	DATE	REV	DATE
1.0	1999	1.0	1999
1.0	2000	1.0	2000
1.0	2001	1.0	2001
1.0	2002	1.0	2002

# 2.Ohms/Buzzer Meas Board CCT's

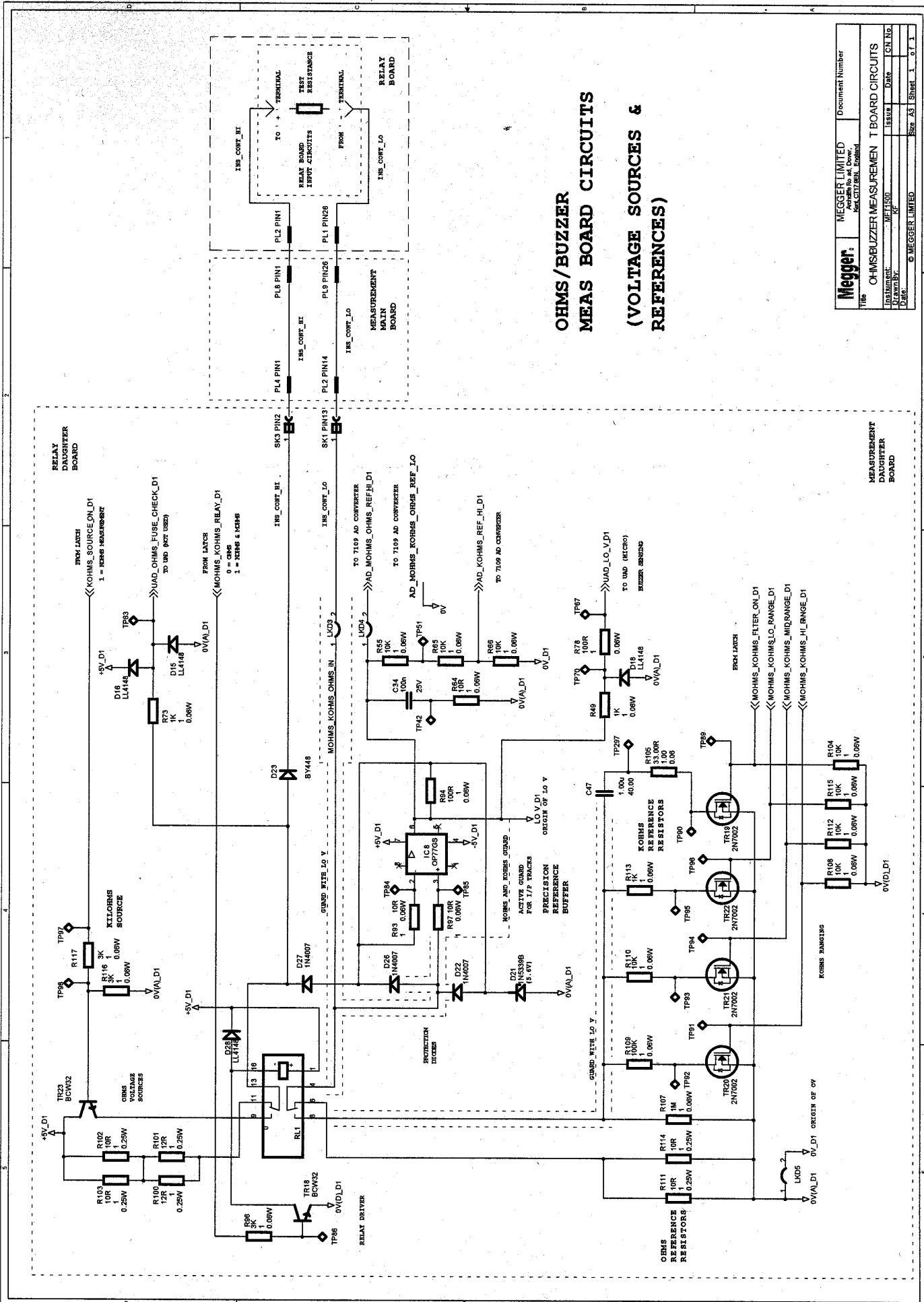

<b>Megger</b>		MEGGER LIMITED		Document Number	
The		OHMS/BUZZER MEASUREMENT BOARD CIRCUITS			
INSTRUMENT	DATE	ISSUE	DATE	CSN NO.	
DRAWN BY:	DATE	BY	DATE	CSN NO.	
CHKD BY:	DATE	BY	DATE	CSN NO.	
DATE:					
© MEGGER LIMITED		See A31 Sheet 1 of 1			

# 3.Ohms Relay Board CCT's

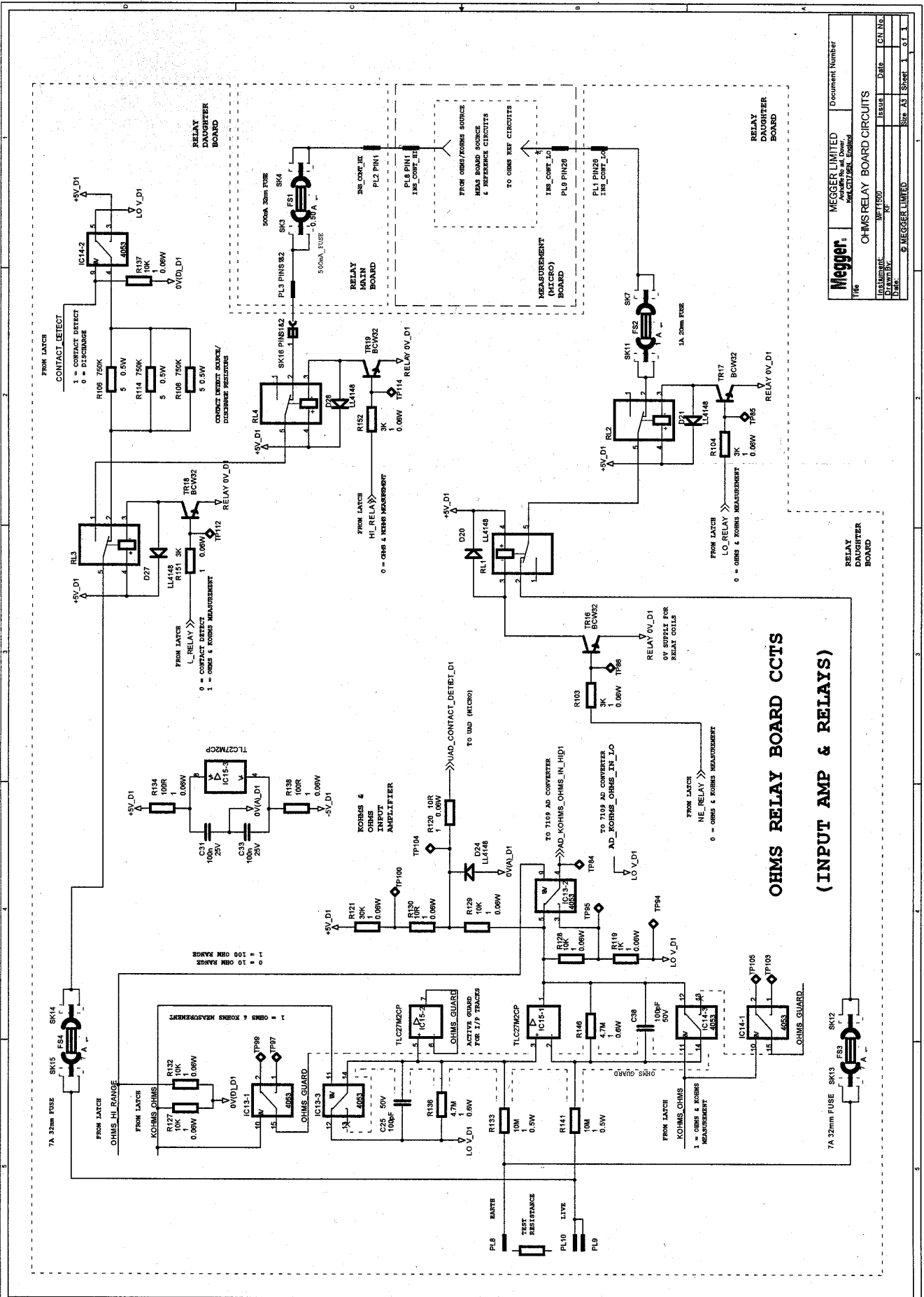

Megger		MEGGER LIMITED		Document Number	
Title		OHMS RELAY BOARD CIRCUITS			
Instrument	MP11500	Issue		Date	01.1
Drawn By	RF	Rev			
Scale		Size	A3	Sheet	1 of 1
		© MEGGER LIMITED			



## **4.Probe CCT**

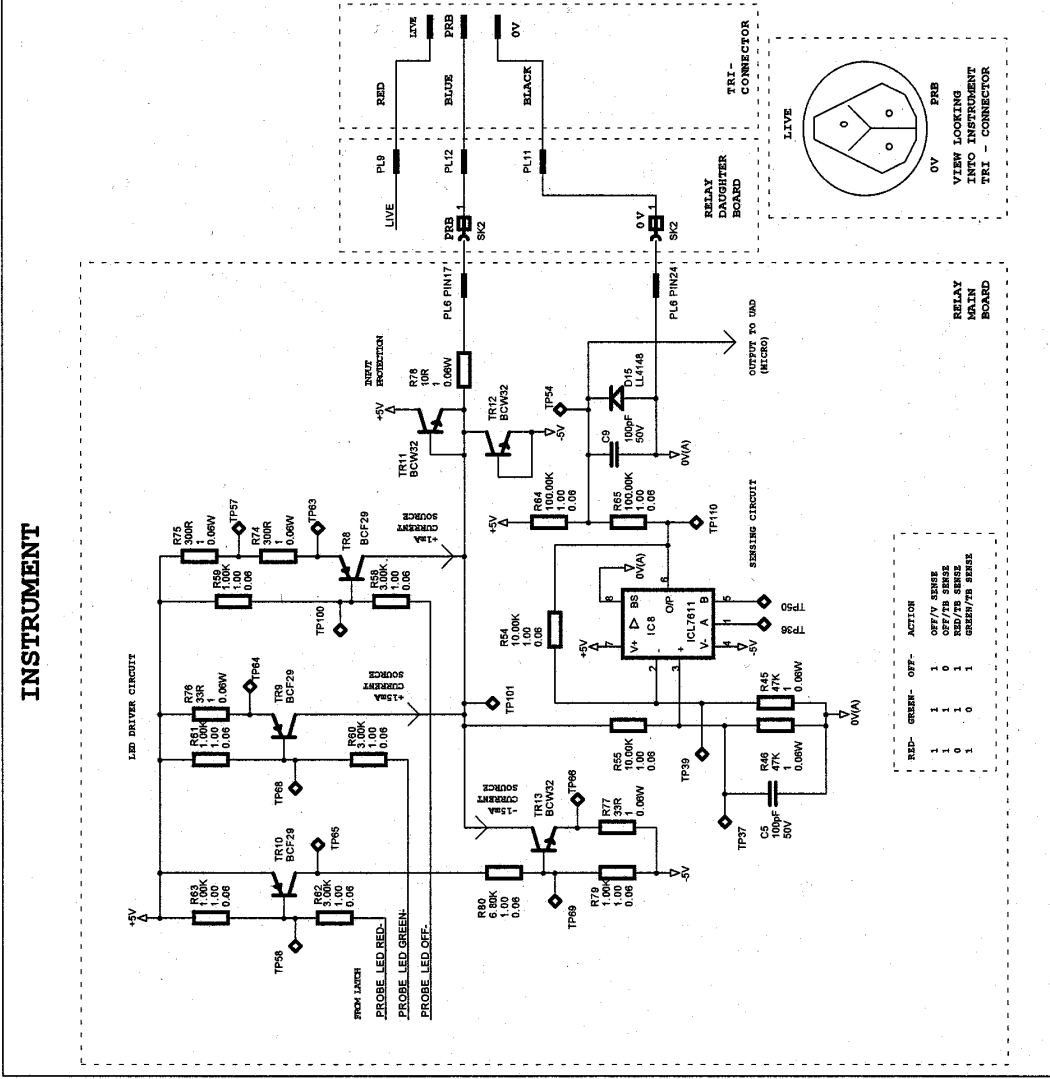
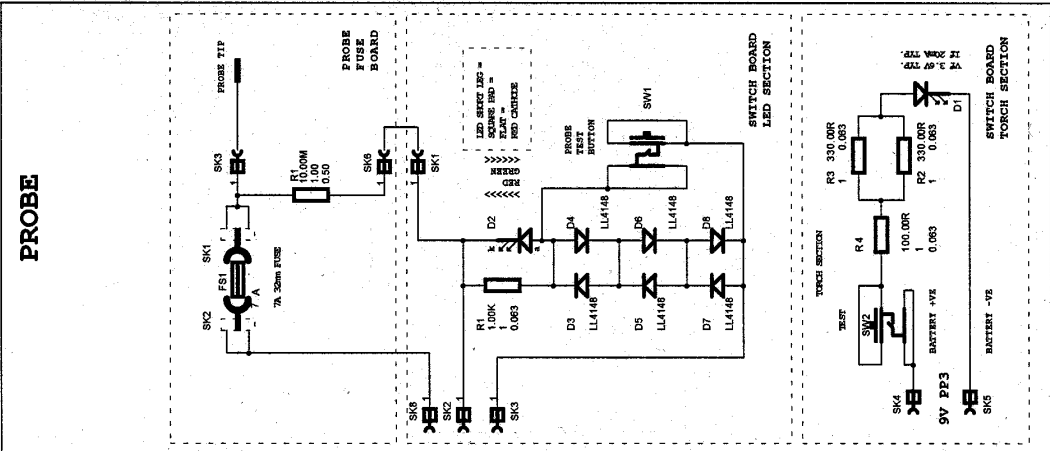

**MEGGER LIMITED**  
 115  
 COMPLETE PROBE CIRCUIT

DESIGNED BY: MFT/1990  
 DRAWN BY: KF  
 DATE: \_\_\_\_\_

ISSUE: \_\_\_\_\_

CHK NO.: \_\_\_\_\_

SIZE: A3 SHEET: 1 OF 1

Document Number

- SHEET 1 - INLET RELAYS
- SHEET 2 - INLET RELAYS CONTINUITY FILTERS
- SHEET 3 - CONTINUITY FILTERS
- SHEET 4 - INLET CONDITIONING
- SHEET 5 - INLET CONDITIONING
- SHEET 6 - INLET CONDITIONING
- SHEET 7 - MICRO PERIPHERALS
- SHEET 8 - MICRO PERIPHERALS
- SHEET 9 - DAUGHTER RELAY INTERFACE

### COMPLETE PROBE CIRCUIT

# 5.Voltmeter Relay Board CCT's

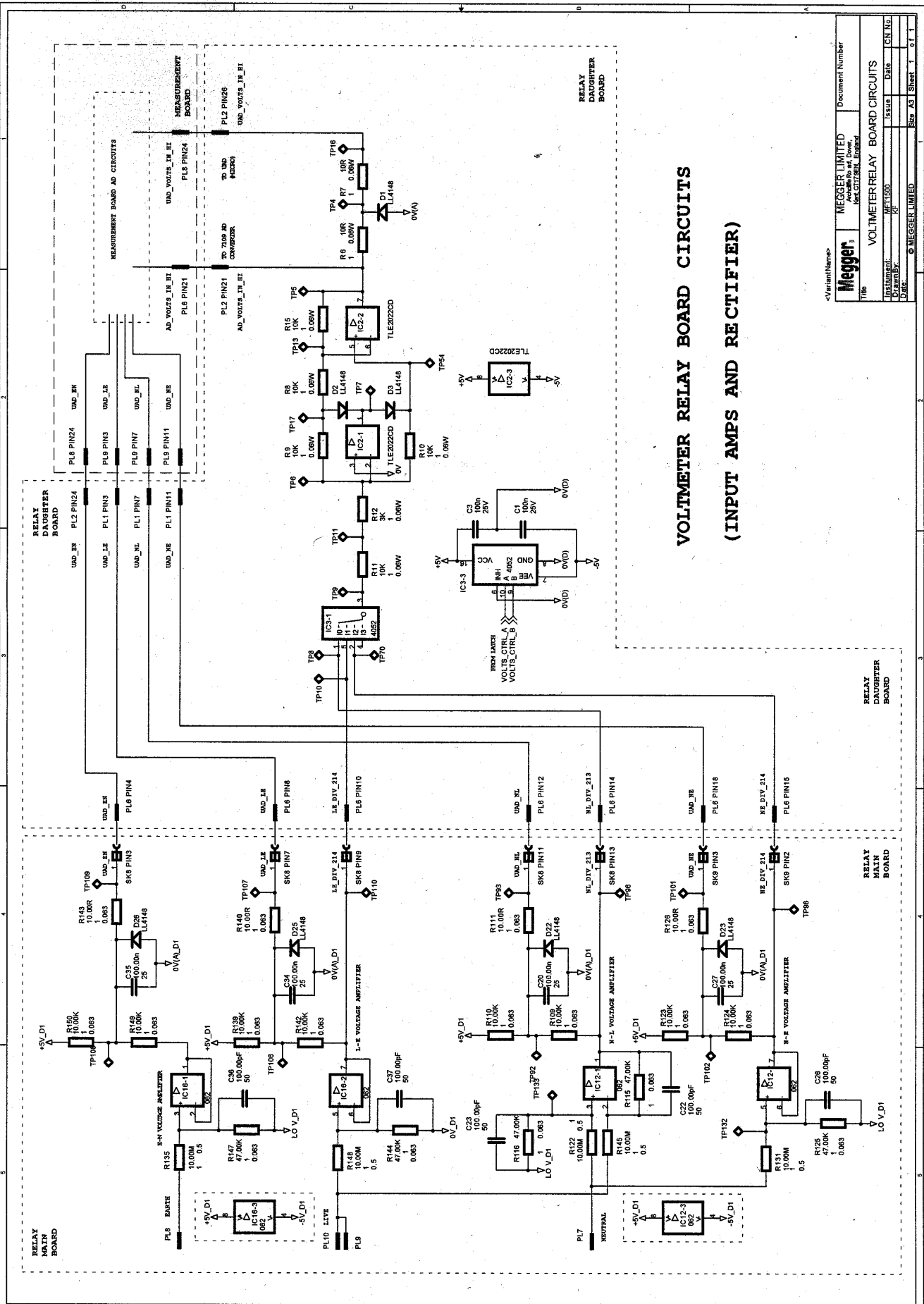

## VOLTMETER RELAY BOARD CIRCUITS (INPUT AMPS AND RECTIFIER)

MEGGER LIMITED A Division of MCCULLOUGH LIMITED		Document Number
VOLTMETER RELAY BOARD CIRCUITS		
Instrument	ME11300	Issue
Drawn By	RF	Date
Check		Sheet
		1 of 1

# 6.RCD CCT Block Diagram

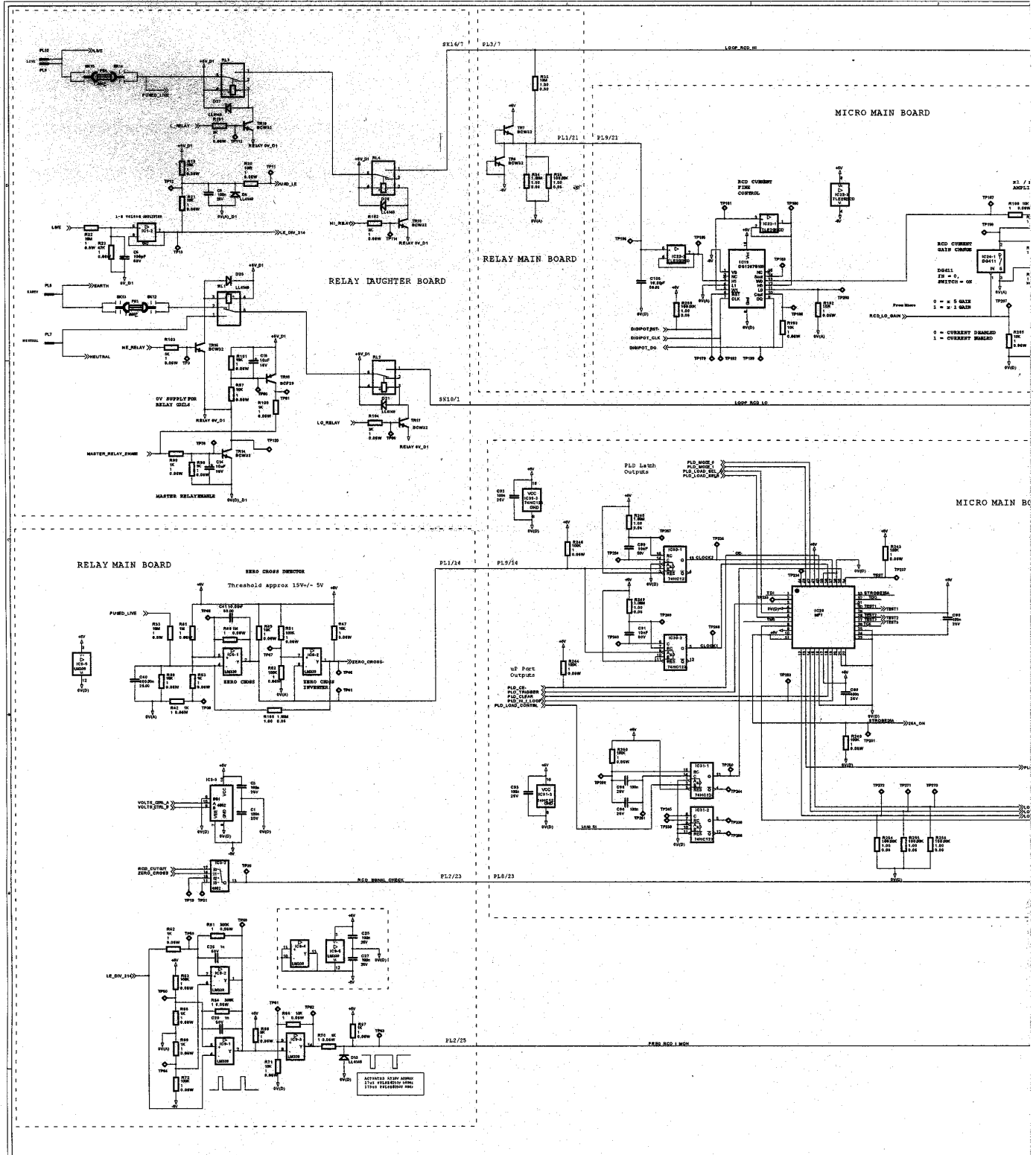

RELAY MAIN BOARD

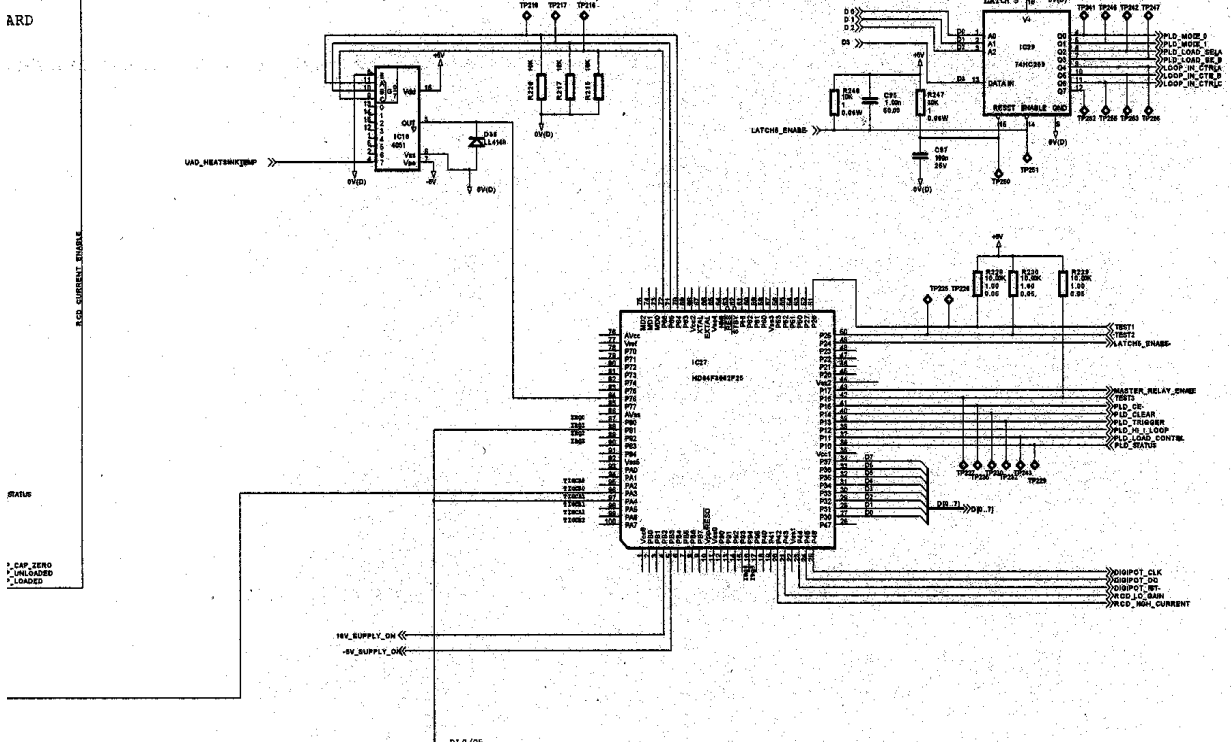
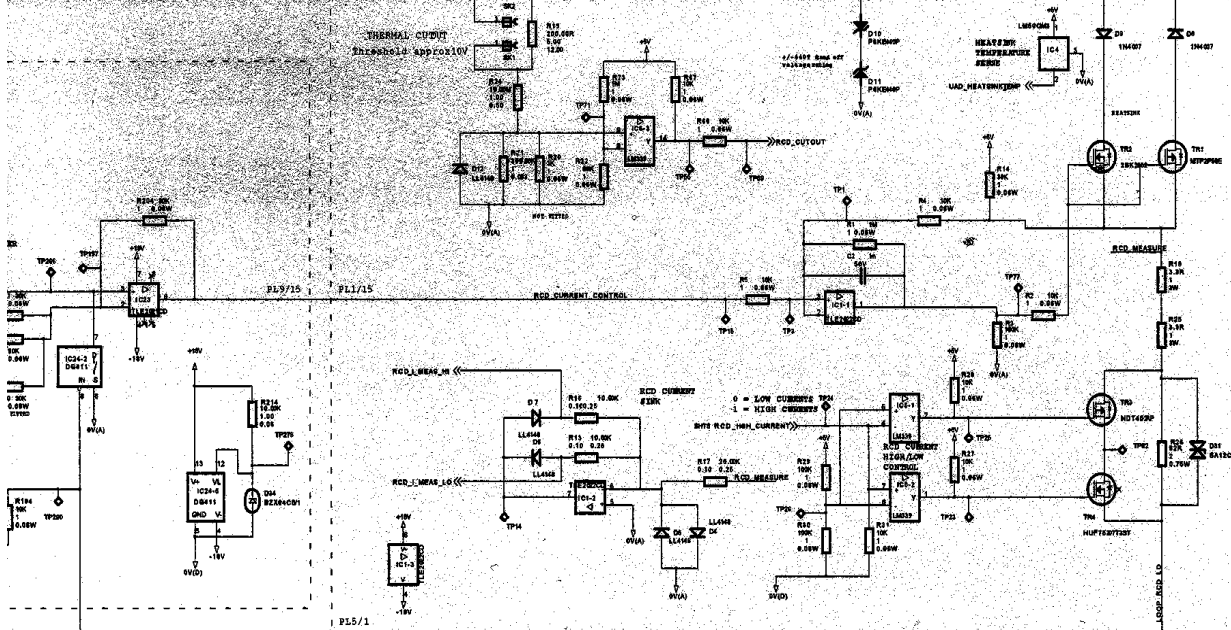

# 7. Loop CCT Block Diagram

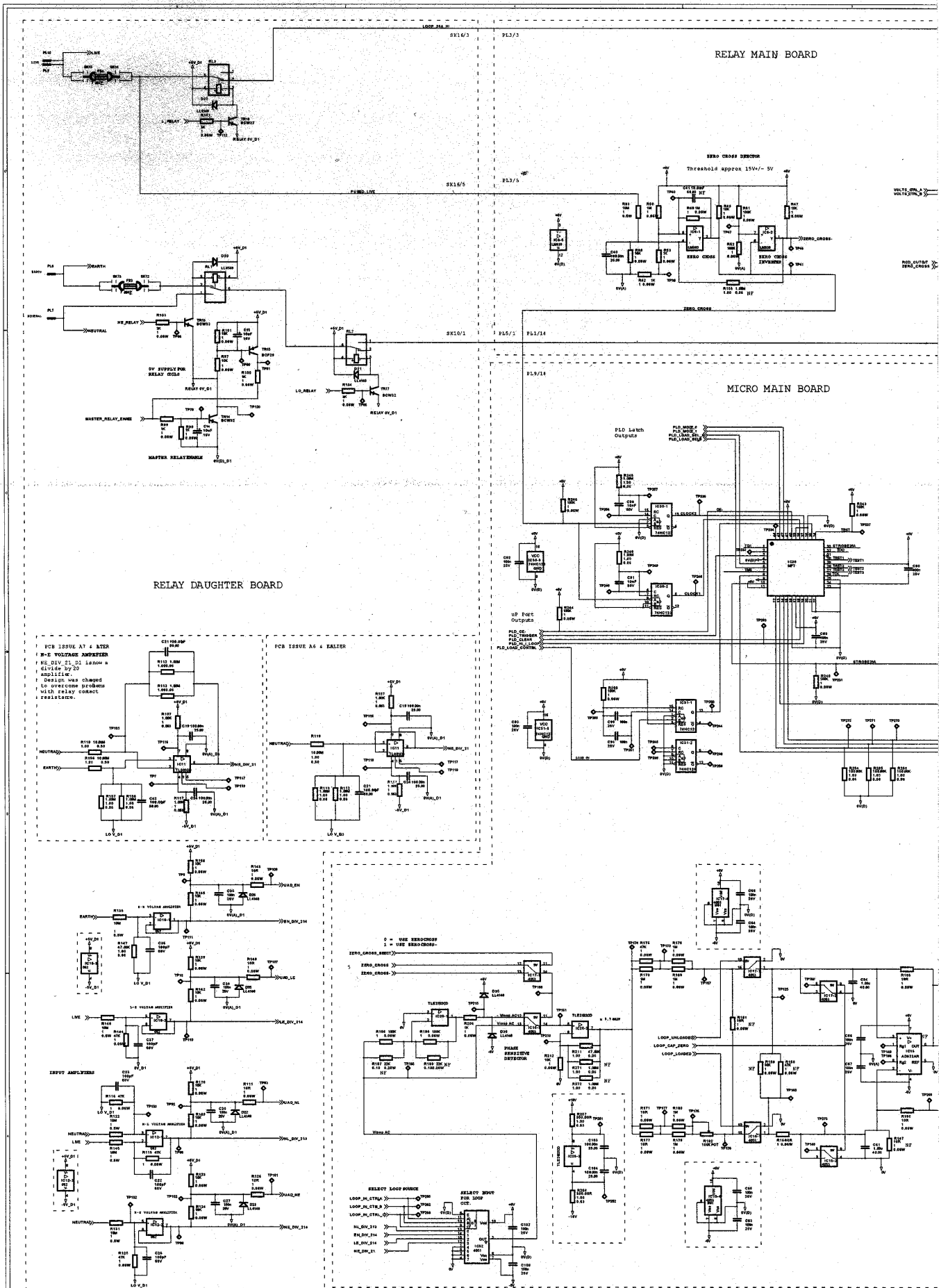

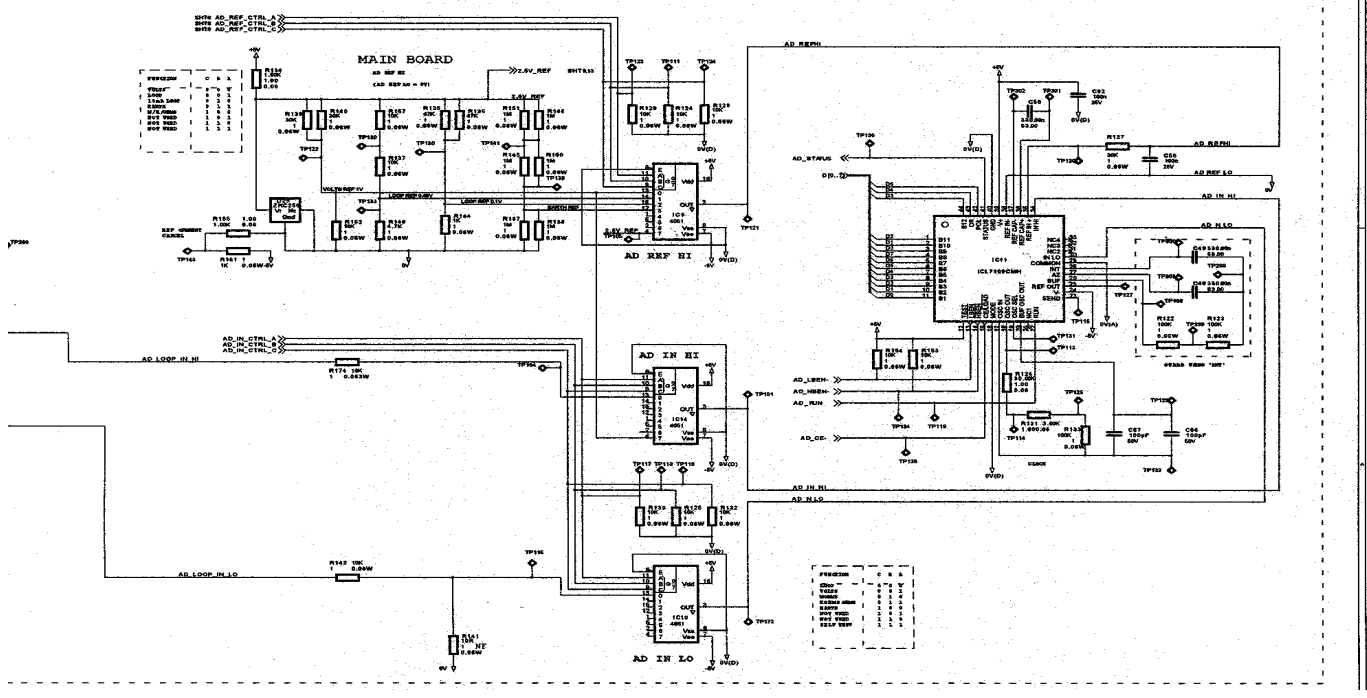
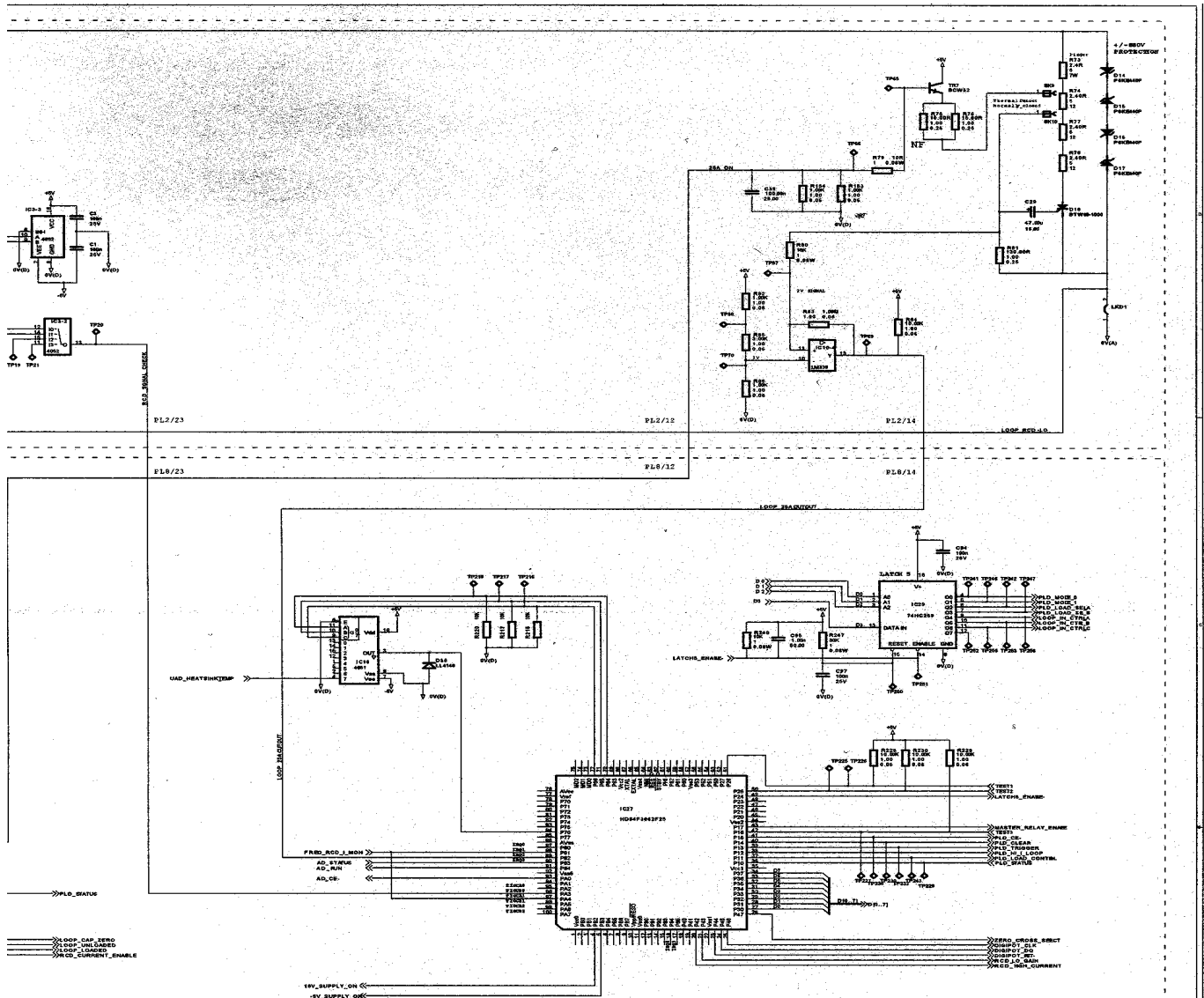

# Appendix 2 Circuit Diagrams

## 1. Display CCT

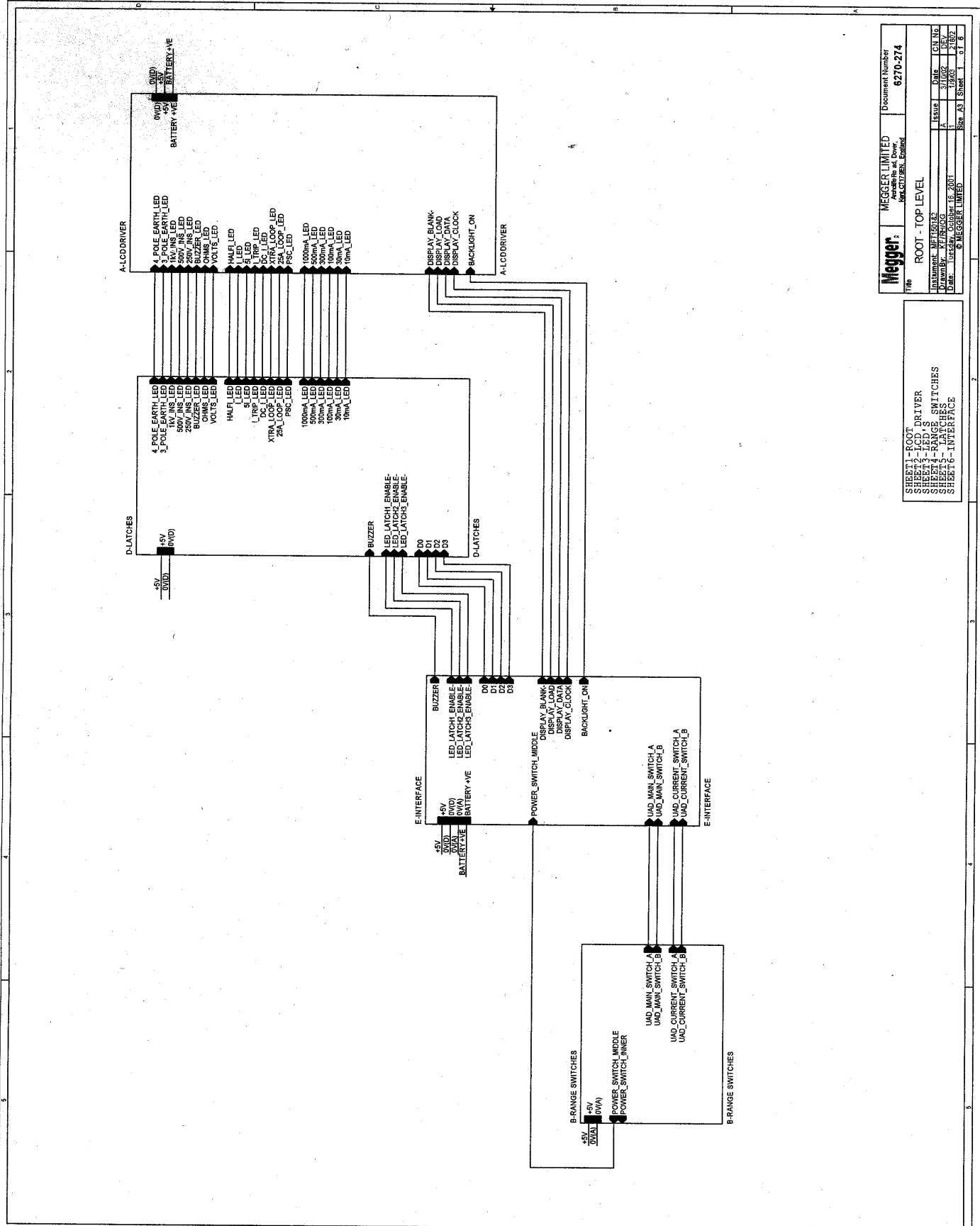

<b>Megger</b>		MEGGER LIMITED		Document Number	
Awards for Quality		ISO 9001:2008 Certified		6270-274	
Title: ROOT - TOP LEVEL					
Drawn by:	Checked by:	Rev:	Rev:	Rev:	Rev:
DATE:	DATE:	1	1	1	1
19/03/08	21/02/08	1	1	1	1
© MEGGER LIMITED		Sheet 1 of 6			

SHEET 1 - ROOT
SHEET 2 - LCD DRIVER
SHEET 3 - LED SWITCHES
SHEET 4 - LATCHES
SHEET 5 - INTERFACE



# DISPLAY BOARD

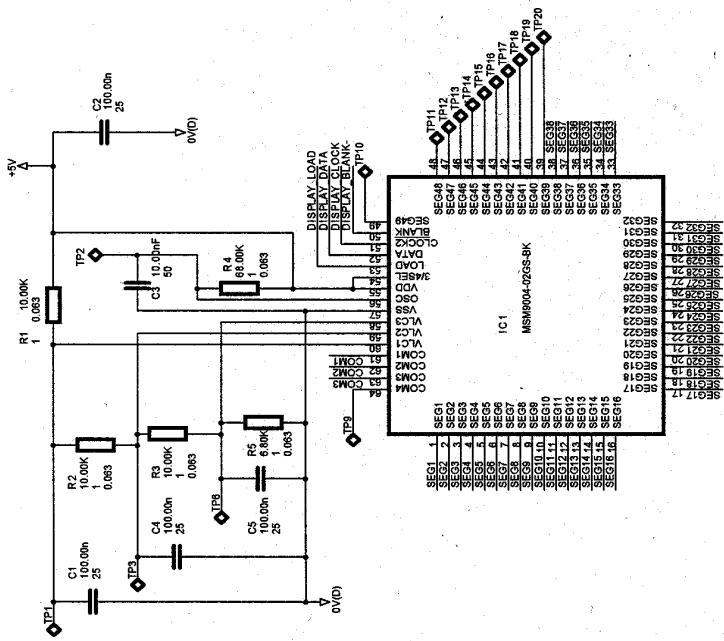
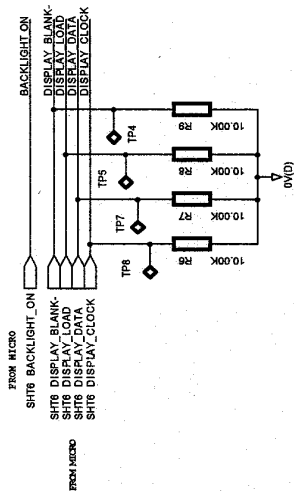

COM1	1	C1	1	SEG38
COM2	2	C1	2	SEG39
COM3	3	C1	3	SEG40
COM4	4	C1	4	SEG41
COM5	5	C1	5	SEG42
COM6	6	C1	6	SEG43
COM7	7	C1	7	SEG44
COM8	8	C1	8	SEG45
COM9	9	C1	9	SEG46
COM10	10	C1	10	SEG47
COM11	11	C1	11	SEG48
COM12	12	C1	12	SEG49
COM13	13	C1	13	SEG50
COM14	14	C1	14	SEG51
COM15	15	C1	15	SEG52
COM16	16	C1	16	SEG53
COM17	17	C1	17	SEG54
COM18	18	C1	18	SEG55
COM19	19	C1	19	SEG56
COM20	20	C1	20	SEG57
COM21	21	C1	21	SEG58
COM22	22	C1	22	SEG59
COM23	23	C1	23	SEG60
COM24	24	C1	24	SEG61
COM25	25	C1	25	SEG62
COM26	26	C1	26	SEG63
COM27	27	C1	27	SEG64
COM28	28	C1	28	SEG65
COM29	29	C1	29	SEG66
COM30	30	C1	30	SEG67
COM31	31	C1	31	SEG68
COM32	32	C1	32	SEG69
COM33	33	C1	33	SEG70
COM34	34	C1	34	SEG71
COM35	35	C1	35	SEG72
COM36	36	C1	36	SEG73
COM37	37	C1	37	SEG74
COM38	38	C1	38	SEG75
COM39	39	C1	39	SEG76
COM40	40	C1	40	SEG77
COM41	41	C1	41	SEG78
COM42	42	C1	42	SEG79
COM43	43	C1	43	SEG80
COM44	44	C1	44	SEG81
COM45	45	C1	45	SEG82
COM46	46	C1	46	SEG83
COM47	47	C1	47	SEG84
COM48	48	C1	48	SEG85
COM49	49	C1	49	SEG86
COM50	50	C1	50	SEG87
COM51	51	C1	51	SEG88
COM52	52	C1	52	SEG89
COM53	53	C1	53	SEG90
COM54	54	C1	54	SEG91
COM55	55	C1	55	SEG92
COM56	56	C1	56	SEG93
COM57	57	C1	57	SEG94
COM58	58	C1	58	SEG95
COM59	59	C1	59	SEG96
COM60	60	C1	60	SEG97
COM61	61	C1	61	SEG98
COM62	62	C1	62	SEG99
COM63	63	C1	63	SEG100

CUSTOM LCD

# LCD DRIVER & BACKLIGHT

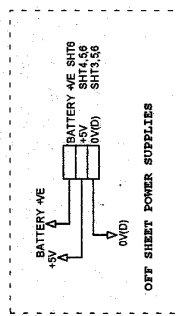
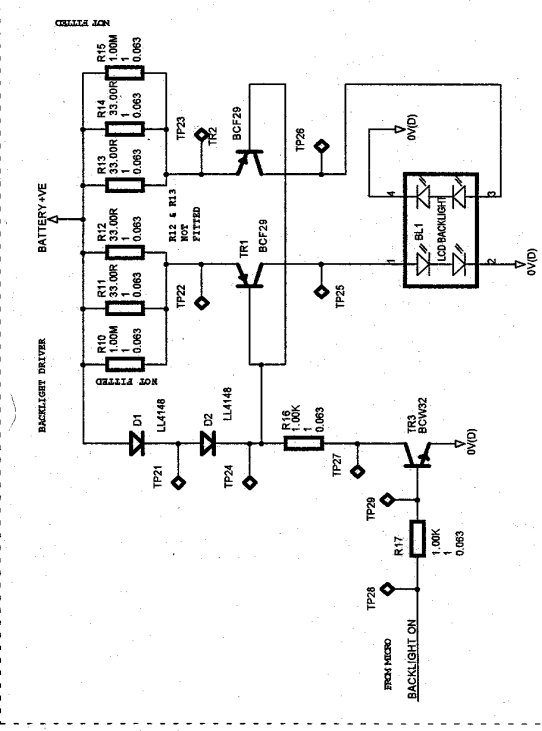

**Megger** MEGGER LIMITED  
 Perthville Rd. Dorrer, MCGILL/PER. Central

This LCD DRIVER  
 DRAWN BY: K. R. HUGHES  
 DATE: Thursday, June 13, 2002  
 © MEGGER LIMITED

Document Number 6270-274

REV	DATE	BY	CHK
1	2/10/02	DEV	CSN MD
2	10/03	2102	

See A31 Sheet 2 of 8

SHEET 1 - ROOT  
 SHEET 2 - LCD DRIVER  
 SHEET 3 - LED'S  
 SHEET 4 - RANGE SWITCHES  
 SHEET 5 - RANGE SWITCHES  
 SHEET 6 - INTERFACE

# FRONT PANEL LEADS

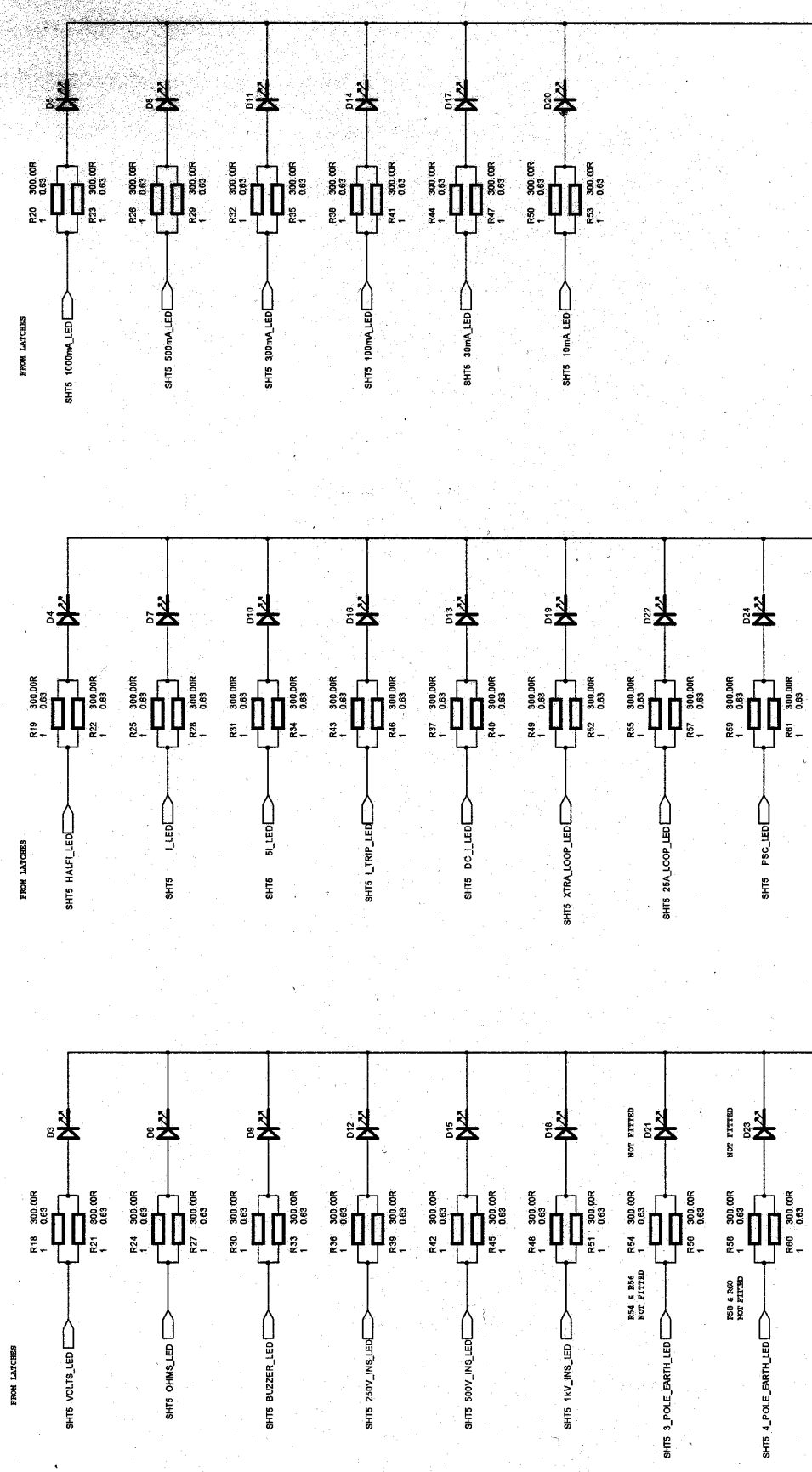

LED SHORT LEG = SQUARE PAD = FLAT = CATHODE

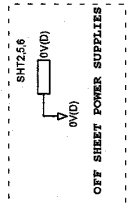

<b>Megger</b>		MEGGER LIMITED		Document Number	
118		FRONT PANEL LEADS		6270-274	
DATE	ISSUE	DATE	ISSUE	DATE	ISSUE
31/07/07	1	31/07/07	1	31/07/07	1
DRAWN BY: K785206		DRAWN BY: K785206		DRAWN BY: K785206	
CHKD BY: J785		CHKD BY: J785		CHKD BY: J785	
APP'D BY: J785		APP'D BY: J785		APP'D BY: J785	
SHEET 3 OF 3		SHEET 3 OF 3		SHEET 3 OF 3	

- SHEET 1 - ROOT DRIVER
- SHEET 2 - LCD DRIVER
- SHEET 3 - RANGE SWITCHES
- SHEET 4 - LATCHES
- SHEET 5 - INTERFACE

# DISPLAY BOARD

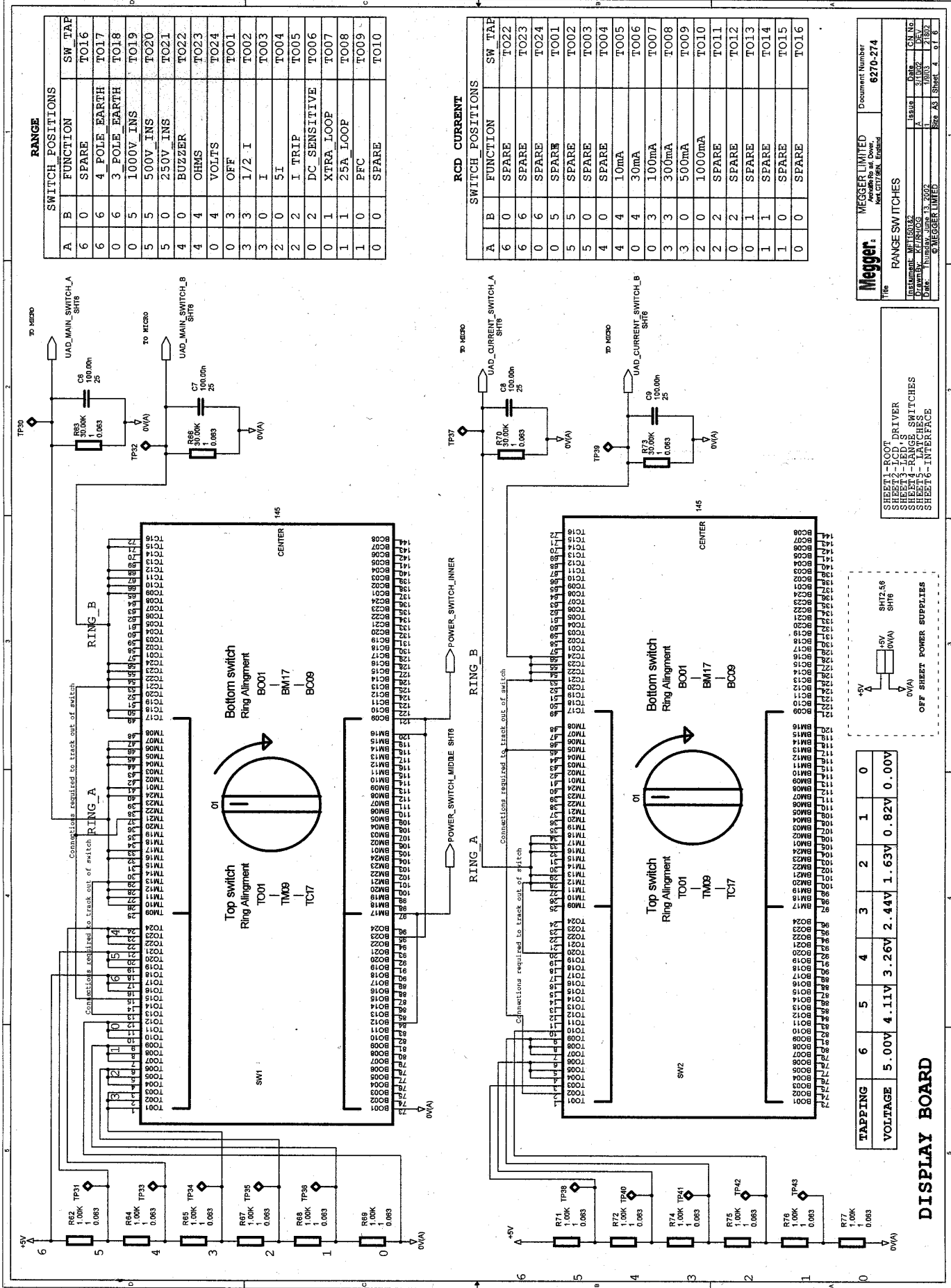

**RANGE SWITCH POSITIONS**

A	B	FUNCTION	SW TAP
6	0	SPARE	TO16
6	0	4 POLE EARTH	TO17
0	6	3 POLE EARTH	TO18
0	5	1000V INS	TO19
5	5	500V INS	TO20
5	0	250V INS	TO21
4	0	BUZZER	TO22
4	4	OHMS	TO23
0	4	VOLTS	TO24
0	3	OFF	TO01
3	3	1/2 I	TO02
3	0	I	TO03
2	0	5I	TO04
2	2	I TRIP	TO05
0	2	DC SENSITIVE	TO06
0	1	XTRA LOOP	TO07
1	1	25A LOOP	TO08
1	0	FFC	TO09
0	0	SPARE	TO10

**RCD CURRENT SWITCH POSITIONS**

A	B	FUNCTION	SW TAP
6	0	SPARE	TO22
6	6	SPARE	TO23
0	6	SPARE	TO24
0	5	SPARE	TO01
5	5	SPARE	TO02
5	0	SPARE	TO03
4	0	SPARE	TO04
4	4	10mA	TO05
0	4	30mA	TO06
0	3	100mA	TO07
3	3	300mA	TO08
3	0	500mA	TO09
2	0	1000mA	TO10
2	2	SPARE	TO11
0	2	SPARE	TO12
0	1	SPARE	TO13
1	1	SPARE	TO14
1	0	SPARE	TO15
0	0	SPARE	TO16

**MEGGER LIMITED**  
 Approved as per Govt. Licences  
 RANGE SWITCHES  
 Document Number: 6270-274  
 Date: 3/10/02  
 Drawn by: K. K. S. S. S.  
 Checked by: J. J. J. J. J.  
 Date: Thursday, June 13, 2002  
 File: 6270-274-01.rvt  
 Sheet: 1 of 6

SHEET 1 - ROOT  
 SHEET 2 - LCD DRIVER  
 SHEET 3 - LED'S  
 SHEET 4 - LED'S SWITCHES  
 SHEET 5 - LED'S  
 SHEET 6 - INTERFACE

OFF SHEET POWER SUPPLIES  
 +5V  
 4V  
 0V(A)  
 SH2.65  
 SH6

**TAPPING VOLTAGE**

6	5	4	3	2	1	0
5.00V	4.11V	3.26V	2.44V	1.63V	0.82V	0.00V

**DISPLAY BOARD**

PORT EXPANSION LATCHES

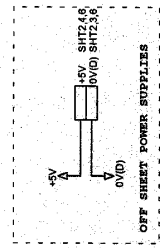
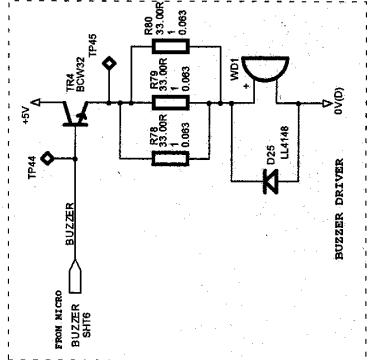
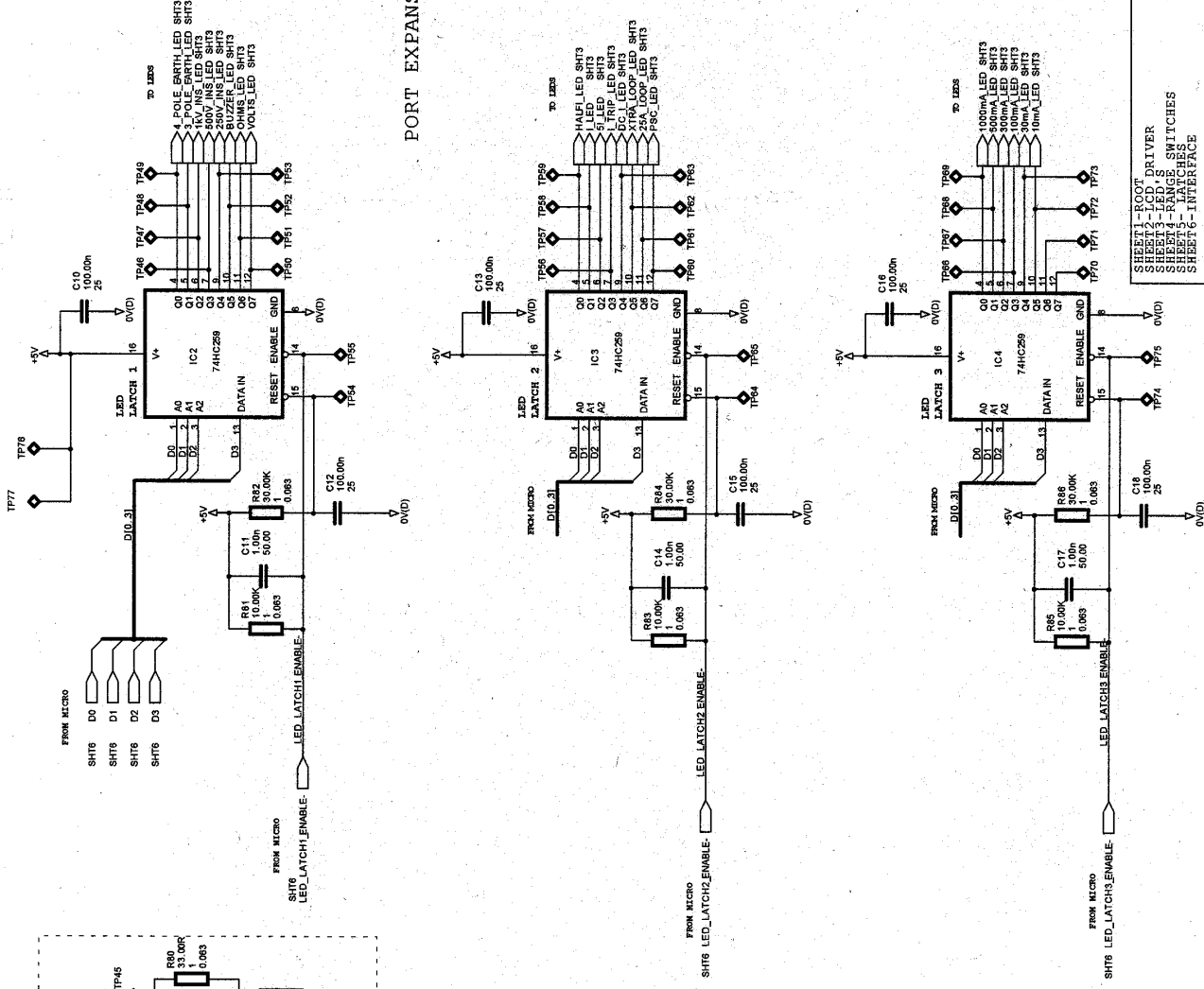

DISPLAY BOARD

SHEET 1 - Buzzer DRIVER  
 SHEET 2 - LED'S  
 SHEET 3 - RANGE SWITCHES  
 SHEET 4 - RANGE SWITCHES  
 SHEET 5 - INTERFACE  
 SHEET 6 - INTERFACE

<b>Megger</b>		MEGGER LIMITED		Document Number			
		1st Floor, 177/178, 179, 180, 181, 182, 183, 184, 185, 186, 187, 188, 189, 190, 191, 192, 193, 194, 195, 196, 197, 198, 199, 200, 201, 202, 203, 204, 205, 206, 207, 208, 209, 210, 211, 212, 213, 214, 215, 216, 217, 218, 219, 220, 221, 222, 223, 224, 225, 226, 227, 228, 229, 230, 231, 232, 233, 234, 235, 236, 237, 238, 239, 240, 241, 242, 243, 244, 245, 246, 247, 248, 249, 250, 251, 252, 253, 254, 255, 256, 257, 258, 259, 260, 261, 262, 263, 264, 265, 266, 267, 268, 269, 270, 271, 272, 273, 274, 275, 276, 277, 278, 279, 280, 281, 282, 283, 284, 285, 286, 287, 288, 289, 290, 291, 292, 293, 294, 295, 296, 297, 298, 299, 300, 301, 302, 303, 304, 305, 306, 307, 308, 309, 310, 311, 312, 313, 314, 315, 316, 317, 318, 319, 320, 321, 322, 323, 324, 325, 326, 327, 328, 329, 330, 331, 332, 333, 334, 335, 336, 337, 338, 339, 340, 341, 342, 343, 344, 345, 346, 347, 348, 349, 350, 351, 352, 353, 354, 355, 356, 357, 358, 359, 360, 361, 362, 363, 364, 365, 366, 367, 368, 369, 370, 371, 372, 373, 374, 375, 376, 377, 378, 379, 380, 381, 382, 383, 384, 385, 386, 387, 388, 389, 390, 391, 392, 393, 394, 395, 396, 397, 398, 399, 400, 401, 402, 403, 404, 405, 406, 407, 408, 409, 410, 411, 412, 413, 414, 415, 416, 417, 418, 419, 420, 421, 422, 423, 424, 425, 426, 427, 428, 429, 430, 431, 432, 433, 434, 435, 436, 437, 438, 439, 440, 441, 442, 443, 444, 445, 446, 447, 448, 449, 450, 451, 452, 453, 454, 455, 456, 457, 458, 459, 460, 461, 462, 463, 464, 465, 466, 467, 468, 469, 470, 471, 472, 473, 474, 475, 476, 477, 478, 479, 480, 481, 482, 483, 484, 485, 486, 487, 488, 489, 490, 491, 492, 493, 494, 495, 496, 497, 498, 499, 500, 501, 502, 503, 504, 505, 506, 507, 508, 509, 510, 511, 512, 513, 514, 515, 516, 517, 518, 519, 520, 521, 522, 523, 524, 525, 526, 527, 528, 529, 530, 531, 532, 533, 534, 535, 536, 537, 538, 539, 540, 541, 542, 543, 544, 545, 546, 547, 548, 549, 550, 551, 552, 553, 554, 555, 556, 557, 558, 559, 560, 561, 562, 563, 564, 565, 566, 567, 568, 569, 570, 571, 572, 573, 574, 575, 576, 577, 578, 579, 580, 581, 582, 583, 584, 585, 586, 587, 588, 589, 590, 591, 592, 593, 594, 595, 596, 597, 598, 599, 600, 601, 602, 603, 604, 605, 606, 607, 608, 609, 610, 611, 612, 613, 614, 615, 616, 617, 618, 619, 620, 621, 622, 623, 624, 625, 626, 627, 628, 629, 630, 631, 632, 633, 634, 635, 636, 637, 638, 639, 640, 641, 642, 643, 644, 645, 646, 647, 648, 649, 650, 651, 652, 653, 654, 655, 656, 657, 658, 659, 660, 661, 662, 663, 664, 665, 666, 667, 668, 669, 670, 671, 672, 673, 674, 675, 676, 677, 678, 679, 680, 681, 682, 683, 684, 685, 686, 687, 688, 689, 690, 691, 692, 693, 694, 695, 696, 697, 698, 699, 700, 701, 702, 703, 704, 705, 706, 707, 708, 709, 710, 711, 712, 713, 714, 715, 716, 717, 718, 719, 720, 721, 722, 723, 724, 725, 726, 727, 728, 729, 730, 731, 732, 733, 734, 735, 736, 737, 738, 739, 740, 741, 742, 743, 744, 745, 746, 747, 748, 749, 750, 751, 752, 753, 754, 755, 756, 757, 758, 759, 760, 761, 762, 763, 764, 765, 766, 767, 768, 769, 770, 771, 772, 773, 774, 775, 776, 777, 778, 779, 780, 781, 782, 783, 784, 785, 786, 787, 788, 789, 790, 791, 792, 793, 794, 795, 796, 797, 798, 799, 800, 801, 802, 803, 804, 805, 806, 807, 808, 809, 810, 811, 812, 813, 814, 815, 816, 817, 818, 819, 820, 821, 822, 823, 824, 825, 826, 827, 828, 829, 830, 831, 832, 833, 834, 835, 836, 837, 838, 839, 840, 841, 842, 843, 844, 845, 846, 847, 848, 849, 850, 851, 852, 853, 854, 855, 856, 857, 858, 859, 860, 861, 862, 863, 864, 865, 866, 867, 868, 869, 870, 871, 872, 873, 874, 875, 876, 877, 878, 879, 880, 881, 882, 883, 884, 885, 886, 887, 888, 889, 890, 891, 892, 893, 894, 895, 896, 897, 898, 899, 900, 901, 902, 903, 904, 905, 906, 907, 908, 909, 910, 911, 912, 913, 914, 915, 916, 917, 918, 919, 920, 921, 922, 923, 924, 925, 926, 927, 928, 929, 930, 931, 932, 933, 934, 935, 936, 937, 938, 939, 940, 941, 942, 943, 944, 945, 946, 947, 948, 949, 950, 951, 952, 953, 954, 955, 956, 957, 958, 959, 960, 961, 962, 963, 964, 965, 966, 967, 968, 969, 970, 971, 972, 973, 974, 975, 976, 977, 978, 979, 980, 981, 982, 983, 984, 985, 986, 987, 988, 989, 990, 991, 992, 993, 994, 995, 996, 997, 998, 999, 1000		MEGGER LIMITED		8270-274	
176		LATCHES		Date			
REVISED BY		DATE		BY			
1		10/03		J.V.			
2		10/03		J.V.			
3		10/03		J.V.			
4		10/03		J.V.			
5		10/03		J.V.			
6		10/03		J.V.			

# 2. Measurement CCT

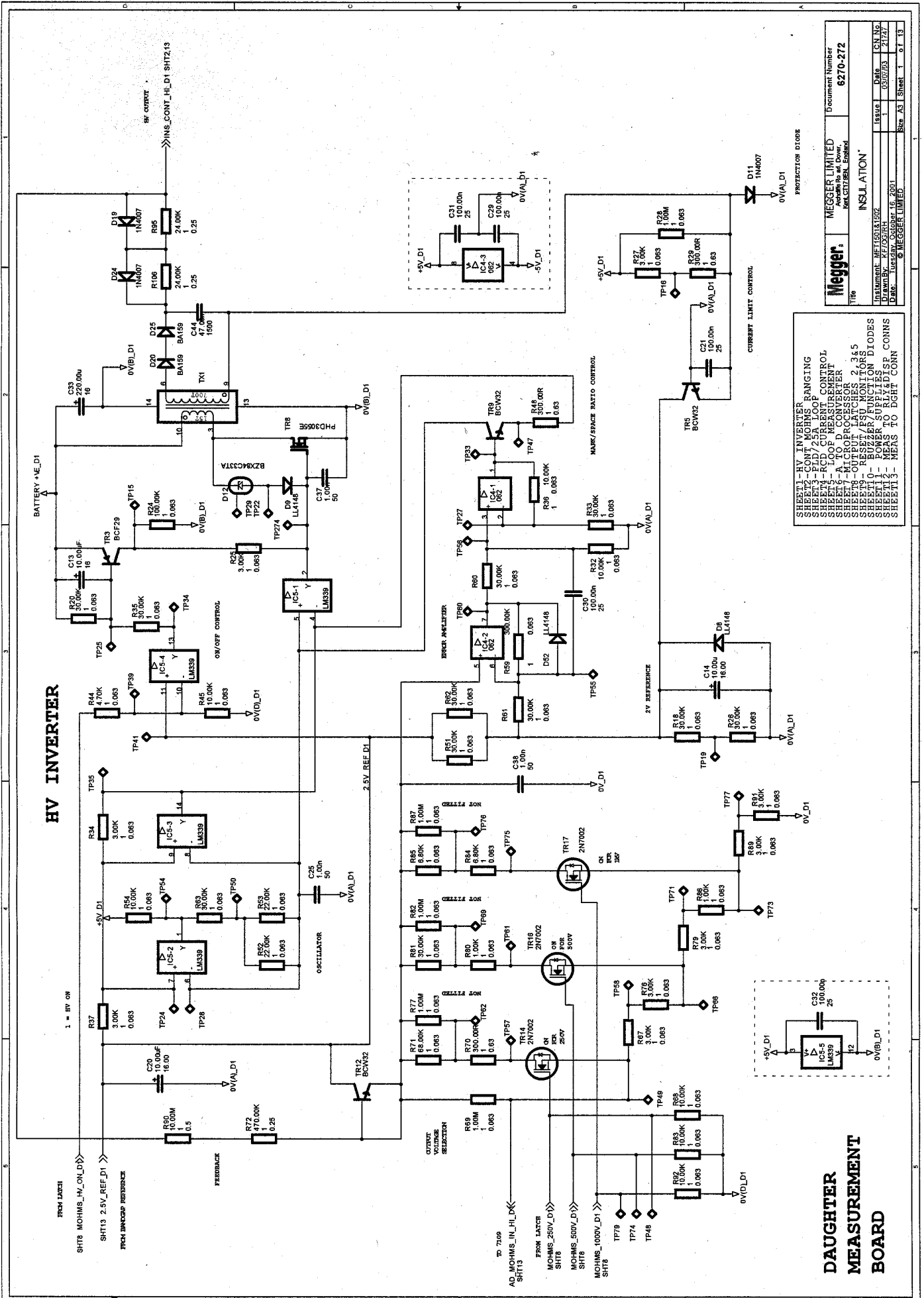

SHEET 1 - HV INVERTER RANGING  
 SHEET 2 - CONT. MOHMS  
 SHEET 3 - PFD/25A LOOP  
 SHEET 4 - RCD CURRENT CONTROL  
 SHEET 5 - TO D CONVERTER  
 SHEET 6 - TO D CONVERTER  
 SHEET 7 - MICROPROCESSOR  
 SHEET 8 - OUTPUT LATCHES 2, 3 & 5  
 SHEET 9 - BUZZER FUNCTION DIODES  
 SHEET 10 - POWER SUPPLIES  
 SHEET 11 - MEAS TO RLY ADI SP CONNS  
 SHEET 12 - MEAS TO DGTI CONN  
 SHEET 13 - MEAS TO DGTI CONN

## DAUGHTER MEASUREMENT BOARD

MEGGER LIMITED		Document Number	6270-272
MEGGER LTD		Issue	1
KENT CTT, BLEN, ENGLAND		Date	03/07/85
Title		INSULATION	
Inclusion: WFT10013192Z		Rev	1
Part: MUG24V 240MM 16 2031		Sheet	1
© MEGGER LIMITED		of	13

# CONTINUITY & MOHMS RANGING

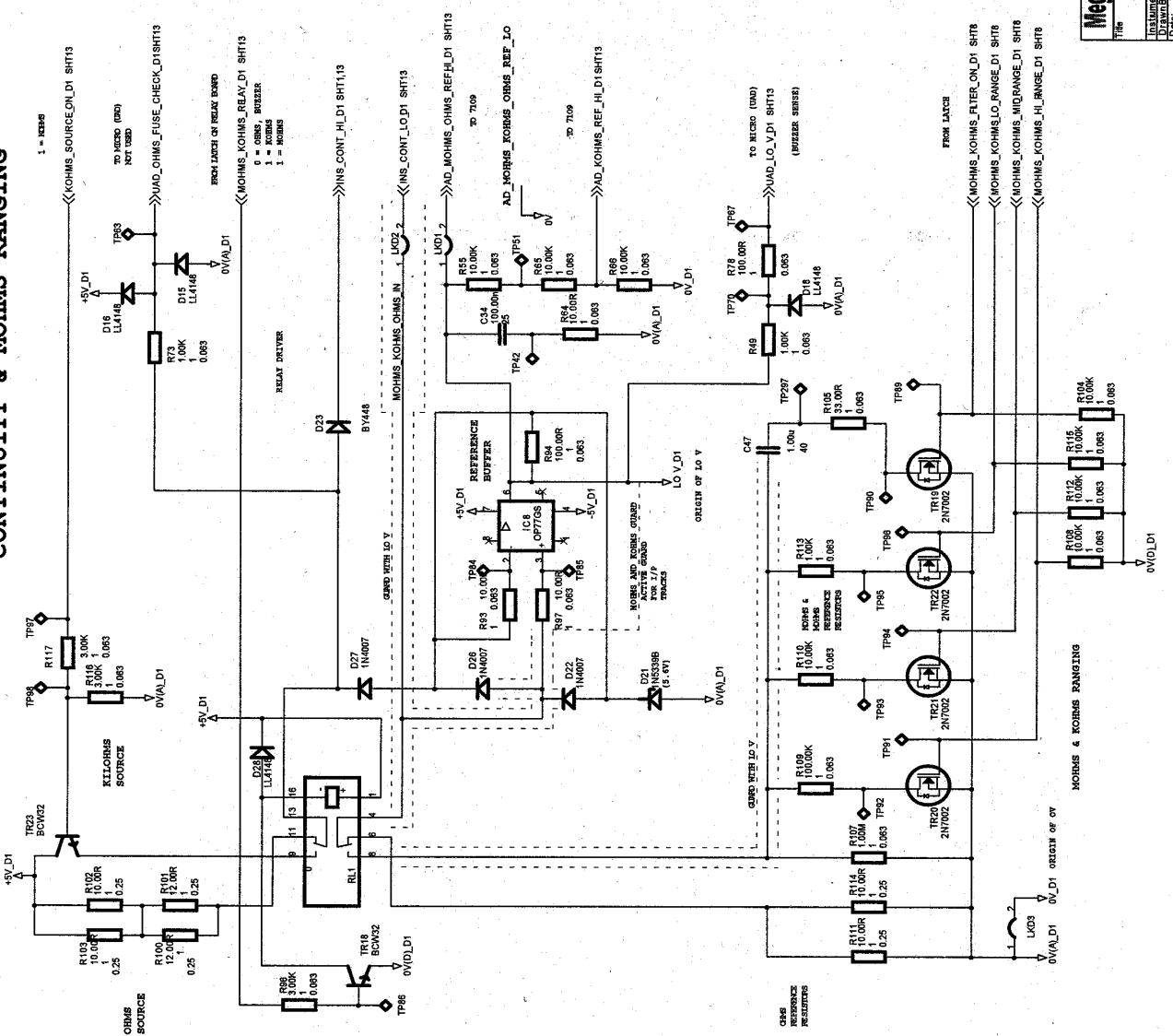

- SHEET 1 - REV. 1
- SHEET 2 - CONTIN. RANGING
- SHEET 3 - RCD CURRENT CONTROL
- SHEET 4 - RCD MEASUREMENT
- SHEET 5 - RCD MEASUREMENT
- SHEET 6 - MICROPROCESSOR
- SHEET 7 - MICROPROCESSOR
- SHEET 8 - OUTPUT LATCHES 2, 3 & 5
- SHEET 9 - BEZEL FUNCTIONS
- SHEET 10 - BEZEL FUNCTIONS
- SHEET 11 - POWER SUPPLIES
- SHEET 12 - MEAS TO RLY/LEDSP. CONNS
- SHEET 13 - MEAS TO LIGHT CONN

MEGGER LIMITED		Document Number	
VELOCITY TRAIN, London		6270-272	
Title OHMS CCT KO HIMS CCT, MOHMS RANGING			
ISSUED	DATE	CN No.	
DRAWN BY: REF703/HR	1	03/07/83	21747
CHKD: HUGHES	15. 2001		
		SIZE: A1	SHEET: 2 of 13

# DAUGHTER MEASUREMENT BOARD

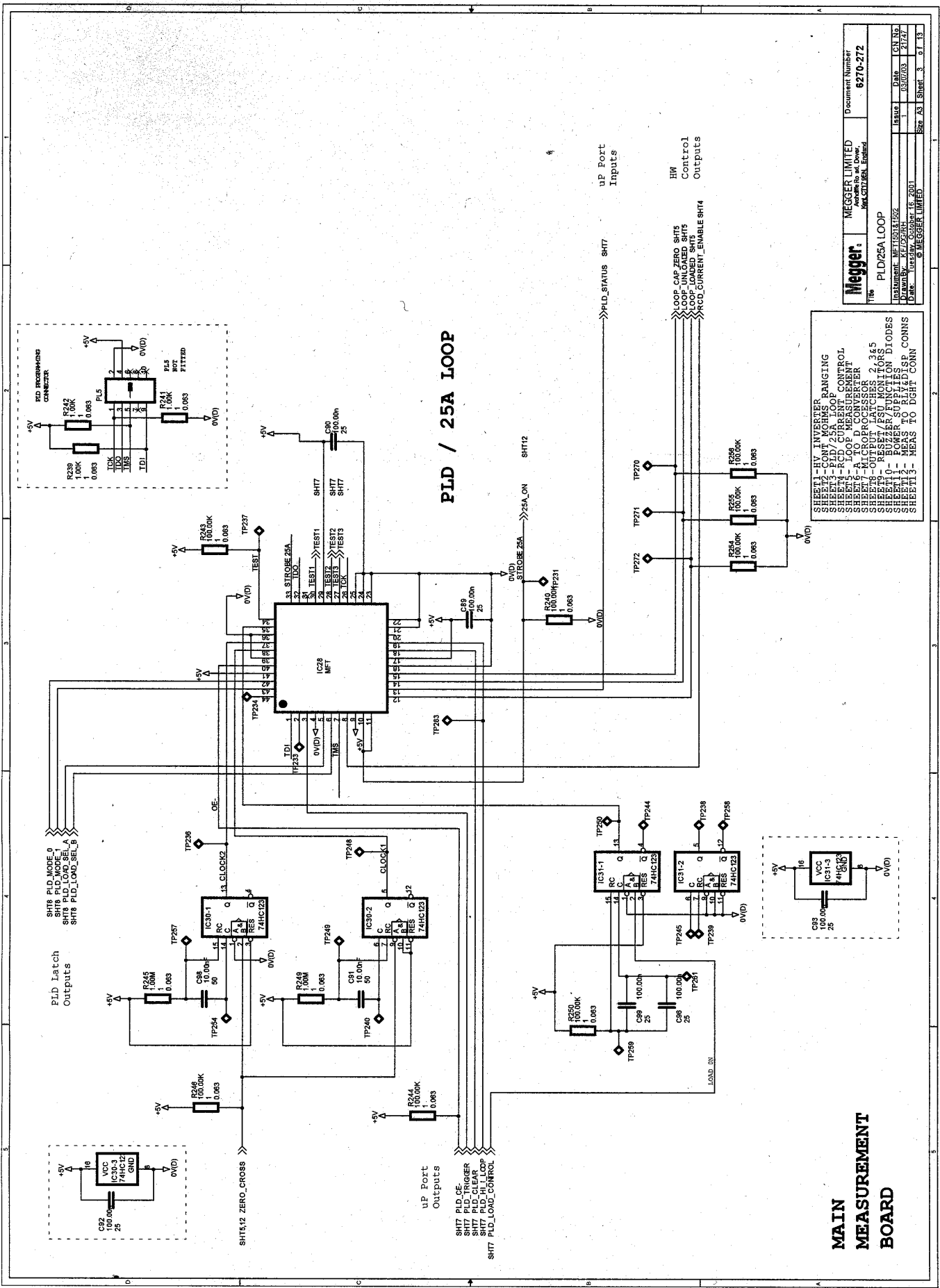

**PLD / 25A LOOP**

**MAIN MEASUREMENT BOARD**

<b>Megger:</b>	MEGGER LIMITED	Document Number	6270-272
Title	PLD/25A LOOP	Issue	1
Drawn by	PLD/25A	Date	03/07/03
Check by	PLD/25A	Issue	1
Drawn by	MEGGER LIMITED	Date	15 2001
Check by	MEGGER LIMITED	Issue	3
Drawn by	MEGGER LIMITED	Date	01 13
Check by	MEGGER LIMITED	Issue	1

- SHEET1 - RV INVERTER RANGING
- SHEET2 - LOOP MEASUREMENT
- SHEET3 - PLD / 25A LOOP
- SHEET4 - RCD CURRENT CONTROL
- SHEET5 - LOOP MEASUREMENT
- SHEET6 - MICROPROCESSOR
- SHEET7 - MICROPROCESSOR
- SHEET8 - OUTPUT LATCHES 2, 3, 4, 5
- SHEET9 - RESET FUNCTION DIODES
- SHEET10 - POWER SUPPLIES
- SHEET11 - MEAS TO RY&D ISP CONNS
- SHEET12 - MEAS TO DGT CONN
- SHEET13 - MEAS TO DGT CONN

# RCD CURRENT CONTROL

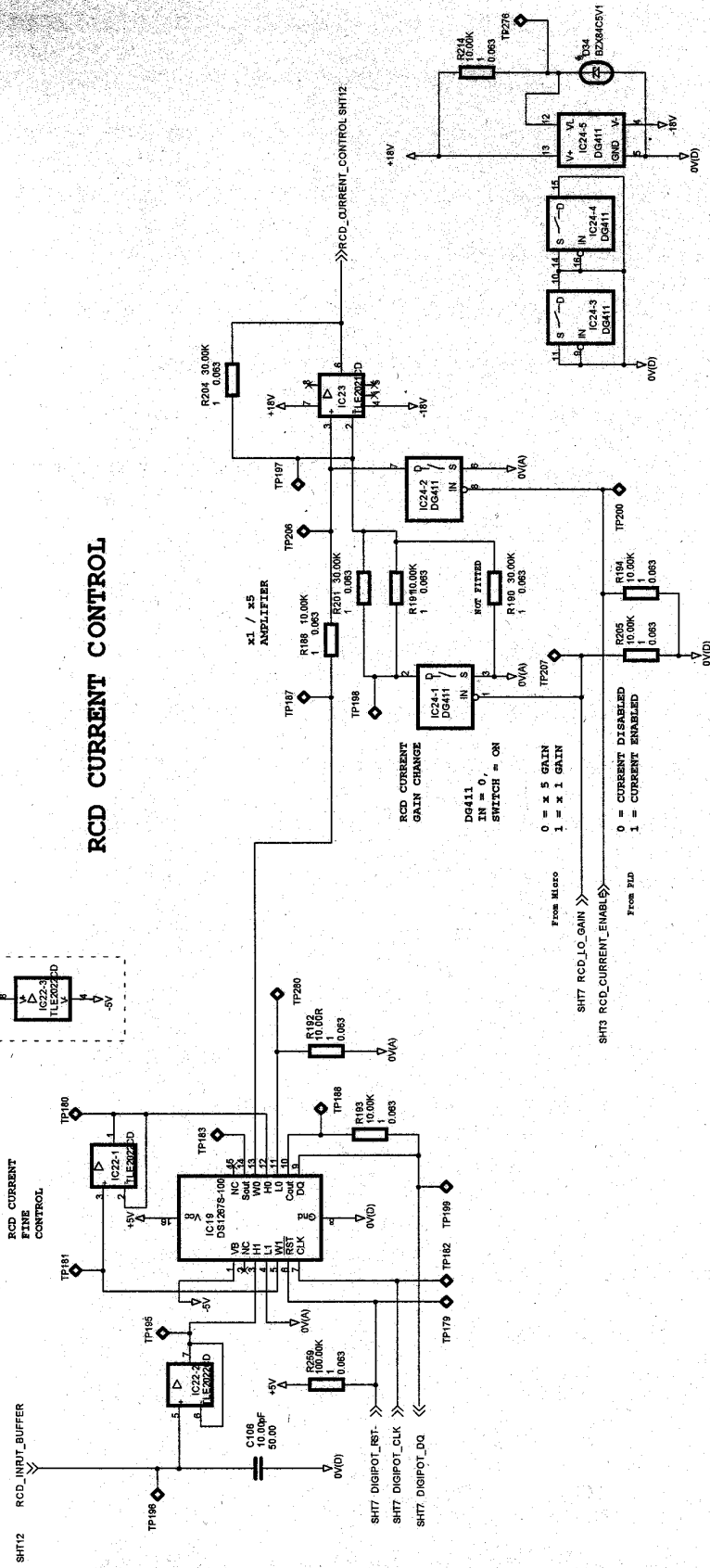
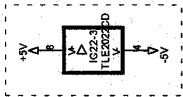

# MAIN MEASUREMENT BOARD

SHEET1 - HV INVERTER  
 SHEET2 - ONLY MATHS RANGING  
 SHEET3 - RCD CURRENT CONTROL  
 SHEET4 - LOOP MEASUREMENT  
 SHEET5 - A COORDINATOR  
 SHEET6 - OUTPUT LATCHES 2,3&5  
 SHEET7 - RESET/PSU MONITORS  
 SHEET8 - POWER SUPPLIES  
 SHEET9 - MEAS TO RLY&DISP CONNS  
 SHEET10 - MEAS TO RLY&DISP CONNS  
 SHEET11 - MEAS TO RLY&DISP CONNS  
 SHEET12 - MEAS TO RLY&DISP CONNS  
 SHEET13 - MEAS TO RLY&DISP CONNS

<b>Megger:</b>	MEGGER LIMITED	Document Number	6270-272
	WALSLEY, ENGLAND		
<b>Title:</b>	RCD CIRCUIT		
<b>Drawn By:</b>	W.F.16014162	<b>Issue:</b>	
<b>Drawn:</b>	K.F.02948	<b>Date:</b>	03/07/83
<b>Date:</b>	14.10.81	<b>Issue:</b>	1
	© MEGGER LIMITED	<b>Rev A3</b>	Sheet 4 of 13



# LOOP MEASUREMENT

0 = USE ZERO CROSS  
 1 = USE ZERO CROSS  
 SHT3 ZERO\_CROSS\_SELECT

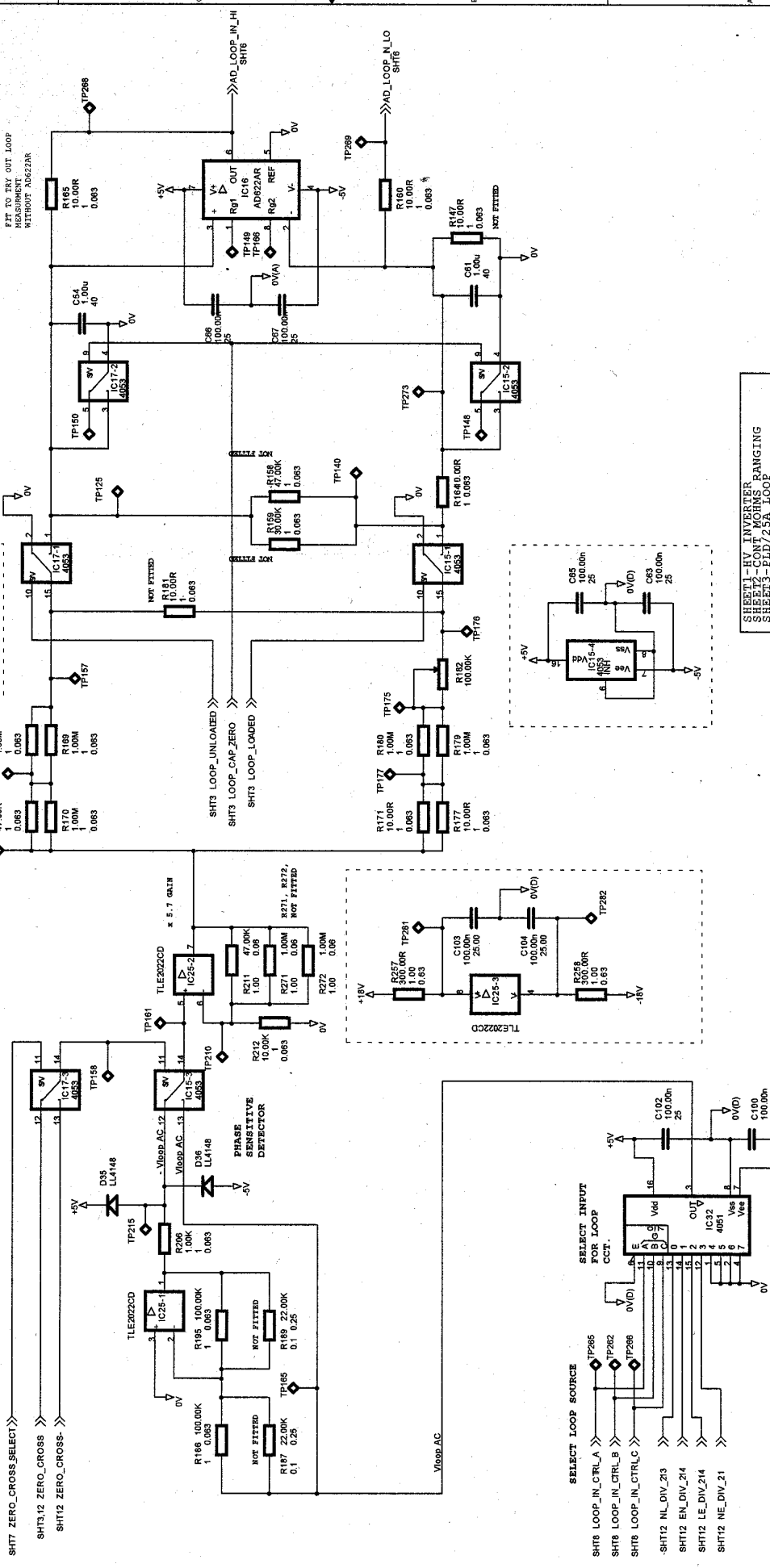

# MAIN MEASUREMENT BOARD

SHEET 1 - MAIN MEASUREMENT BOARD RANGING  
 SHEET 2 - RCD CURRENT CONTROL  
 SHEET 3 - LOOP MEASUREMENT BOARD  
 SHEET 4 - MICROPROCESSOR  
 SHEET 5 - OUTPUT LATCHES 2, 3 & 5  
 SHEET 6 - REFERENCE VOLTAGES  
 SHEET 7 - POWER SUPPLIES  
 SHEET 8 - MEAS TO RLY & DISP CONNS  
 SHEET 9 - MEAS TO RLY & DISP CONNS  
 SHEET 10 - MEAS TO RLY & DISP CONNS  
 SHEET 11 - MEAS TO RLY & DISP CONNS  
 SHEET 12 - MEAS TO RLY & DISP CONNS  
 SHEET 13 - MEAS TO RLY & DISP CONNS

Megger		MEGGER LIMITED		Document Number	
		Kuala Lumpur, Malaysia		6270-272	
Title LOOP MEASUREMENT					
Instrument	ME1190.13.102	Issue	DATE	CN No	CN No
Drawn by	K2/25/33	1	03/07/03	21/27	
Check	U00/00/00	15	2001		
SHEET 3 OF 13					

# MAIN MEASUREMENT BOARD

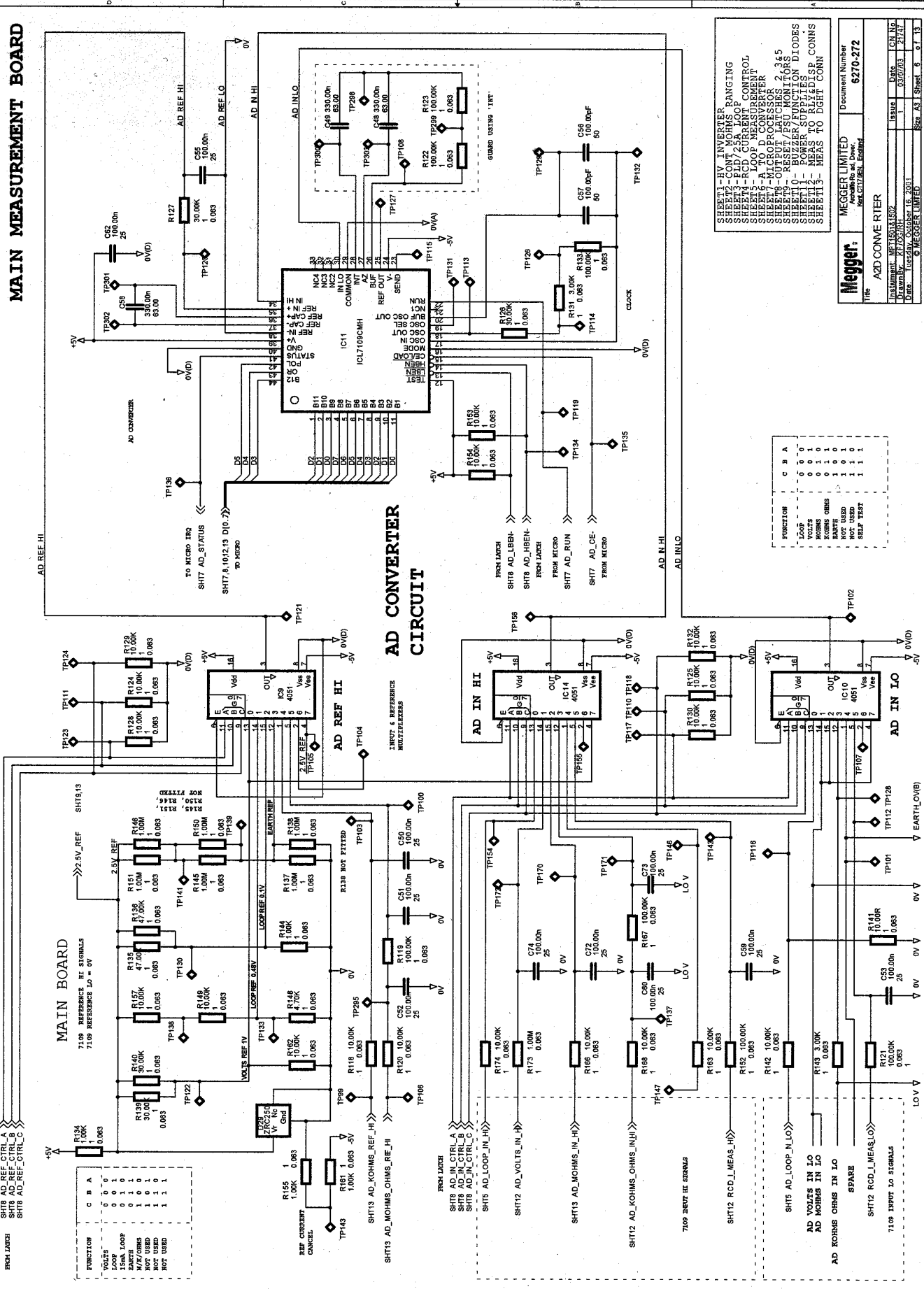

FUNCTION	C	B	A
7015	0	0	0
13mA LOOP	0	0	0
3mA LOOP	0	0	1
2mA LOOP	0	1	1
NOT USED	1	0	1
NOT USED	1	1	1

FUNCTION	C	B	A
Loop	0	0	0
Volts	0	0	0
Kohms	0	1	1
Ohms	0	1	1
NOT USED	1	0	1
NOT USED	1	1	1

FUNCTION	C	B	A
Loop	0	0	0
Volts	0	0	0
Kohms	0	1	1
Ohms	0	1	1
NOT USED	1	0	1
NOT USED	1	1	1

SHEET 1 - REV INVERTER RANGING  
 SHEET 2 - PID/25A LOOP  
 SHEET 3 - RCD CURRENT CONTROL  
 SHEET 4 - LOOP MEASUREMENT  
 SHEET 5 - MICROPROCESSOR  
 SHEET 6 - MICROPROCESSOR  
 SHEET 7 - MICROPROCESSOR  
 SHEET 8 - OUTPUT LATCHES 2, 3, 4, 5  
 SHEET 9 - REFERENCE MONITORS  
 SHEET 10 - REFERENCE MONITORS  
 SHEET 11 - POWER SUPPLIES  
 SHEET 12 - MEAS TO RLV/ISP CONNS  
 SHEET 13 - MEAS TO DGT CONN

**Megger**  
 AZD CONVE RTER  
 MEGER LIMITED  
 6270-272  
 Date: 03/07/83  
 Issue: 1  
 Drawn By: R.FOSHEE  
 Checked By: J.MCGEE/MEGER  
 Doc. No: MEGGER/LIMEED  
 Rev. A3, Sheet 6 of 13

# MICROPROCESSOR

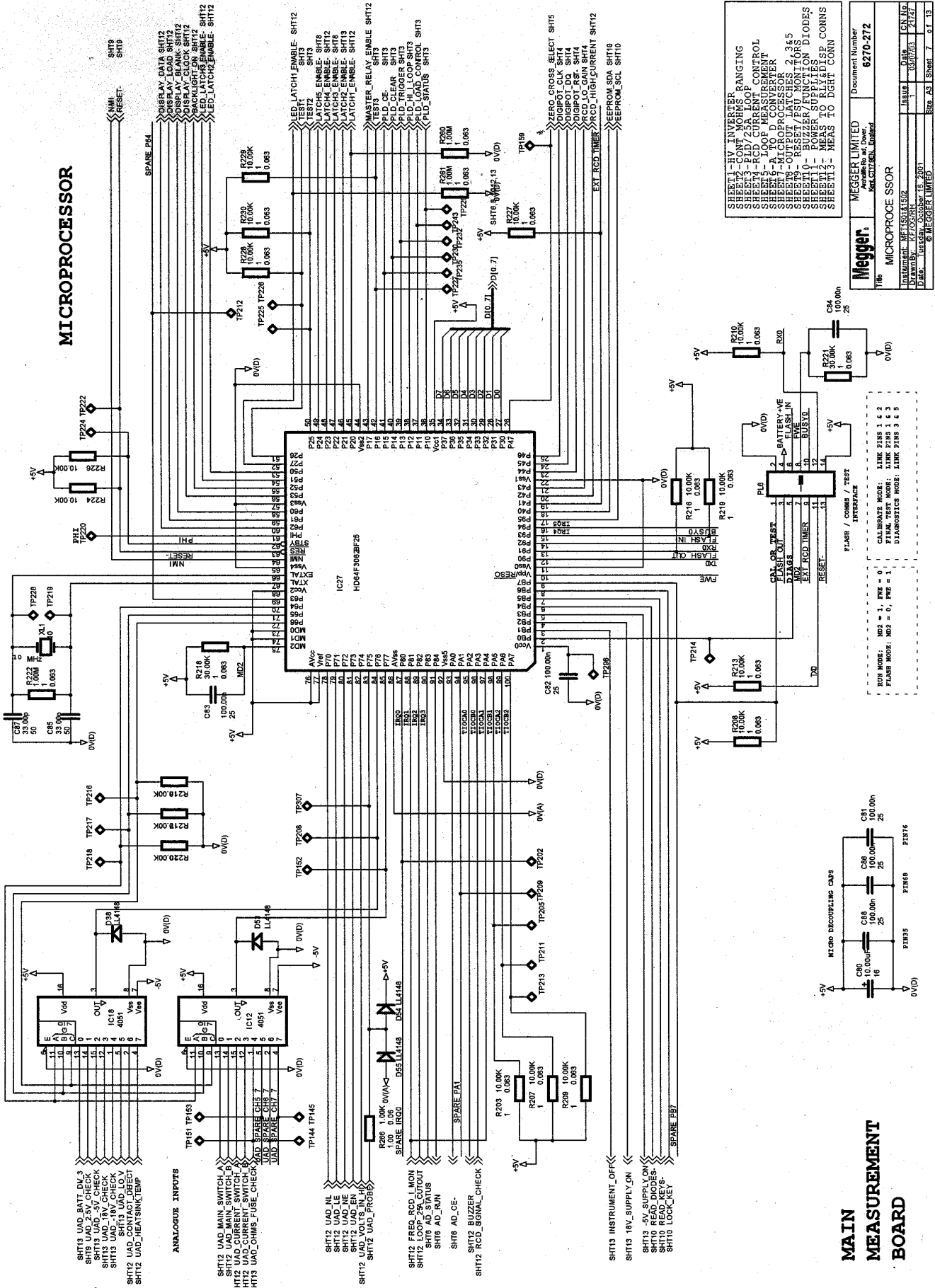

SHEET 1 - HV INVERTER	MEGGER LIMITED	Document Number	6270-272
SHEET 2 - BATTERY MONITORING	MEGGER (UK) LTD	Part Number	6270-272
SHEET 3 - LOOP MEASUREMENT	MEGGER (UK) LTD	Revision	1
SHEET 4 - CURRENT MEASUREMENT	MEGGER (UK) LTD	Issue	DATE
SHEET 5 - MICROPROCESSOR	MEGGER (UK) LTD	Issue	DATE
SHEET 6 - MICROPROCESSOR	MEGGER (UK) LTD	Issue	DATE
SHEET 7 - OUTPUT LATCHES 2, 3 & 5	MEGGER (UK) LTD	Issue	DATE
SHEET 8 - RESET / PSU MONITORS	MEGGER (UK) LTD	Issue	DATE
SHEET 9 - POWER SUPPLIES	MEGGER (UK) LTD	Issue	DATE
SHEET 10 - MEAS TO RL4 DISP CONNS	MEGGER (UK) LTD	Issue	DATE
SHEET 11 - MEAS TO RL4 DISP CONNS	MEGGER (UK) LTD	Issue	DATE
SHEET 12 - MEAS TO RL4 DISP CONNS	MEGGER (UK) LTD	Issue	DATE
SHEET 13 - MEAS TO RL4 DISP CONNS	MEGGER (UK) LTD	Issue	DATE

<b>Megger</b>		MICROPROE SSOR	
Instrument	MFT1581K152	Issue	DATE
Drawn By	KFC/GRH	Issue	DATE
Des.	URGENT/ISSUED 18/2001	Issue	DATE
© MEGGER LIMITED		Rev	AS1 Sheet 7 of 13

# MAIN MEASUREMENT BOARD

# MAIN MEASUREMENT BOARD

LOOP TEST CONTROL LATCH

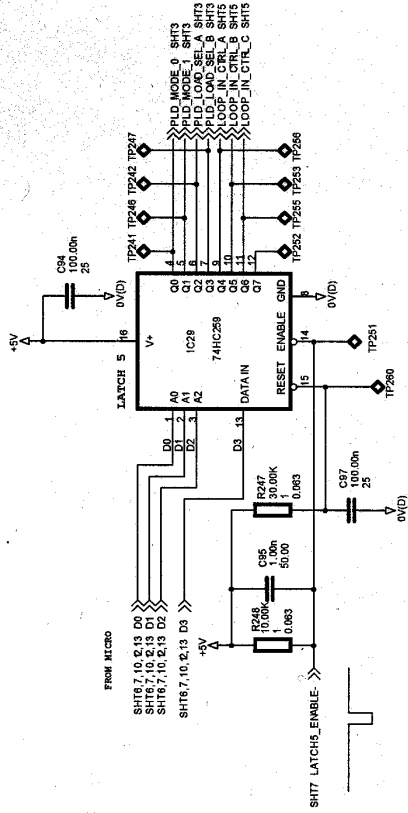

# OUTPUT LATCHES

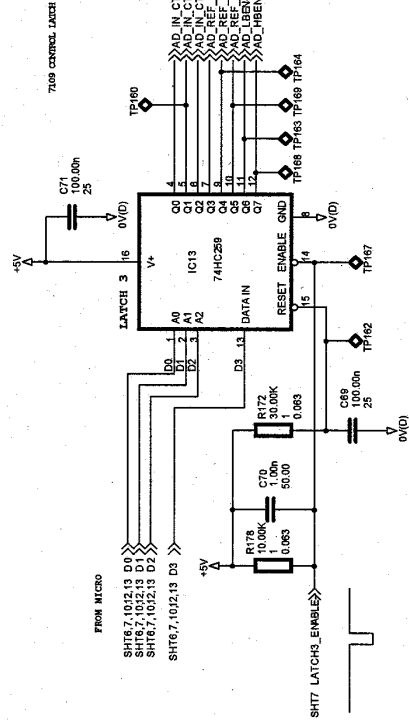

# DAUGHTER MEASUREMENT BOARD

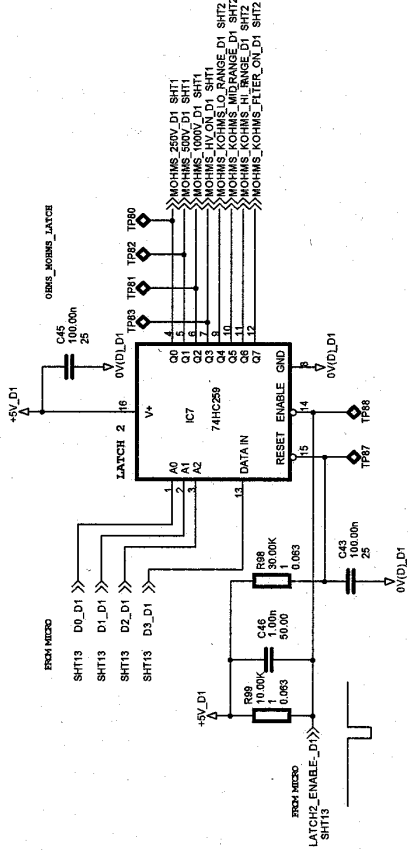

# MAIN MEASUREMENT BOARD

# MAIN BOARD

SHEET11 - HV INVERTER	SHEET12 - CONT. MOHMS RANGING	SHEET13 - ECD / CURRENT CONTROL
SHEET14 - LOOP MEASUREMENT	SHEET15 - TO D CONVERTER	SHEET16 - OUTPUT LATCHES 2, 3&5
SHEET17 - RESET / PSU MONITOR	SHEET18 - RESIZER / FUNCTION DIODES	SHEET19 - MEAS TO RIVADTSP CONNS
SHEET20 - MEAS TO RIVADTSP CONNS	SHEET21 - MEAS TO DGT CONN	

<b>Megger</b>	<b>MEGGER LIMITED</b> Aylesbury Rd. Dover, Kent, CT12 2PL, ENGLAND	Document Number <b>6270-272</b>
Title <b>OUTPUT LATCHES - B</b>		
Drawn <b>W.F.1013/16/92</b>	Issue <b>1</b>	Chk No <b>03/02/03 ZJA/7</b>
Date <b>16/05/99</b>	Proj <b>MEASUREMENT BOARD</b>	Sheet <b>8</b> of <b>13</b>

**5V RAIL MONITORING**

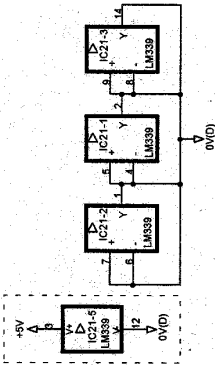
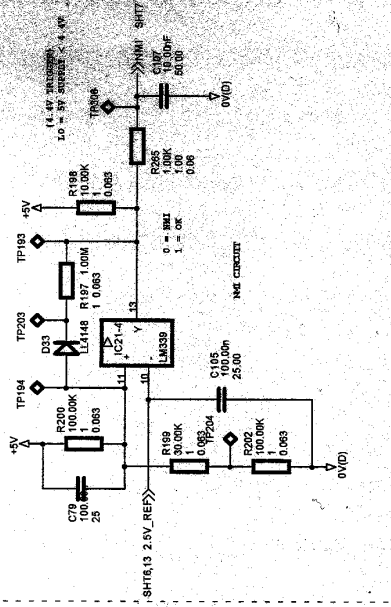

**RESET CIRCUIT**

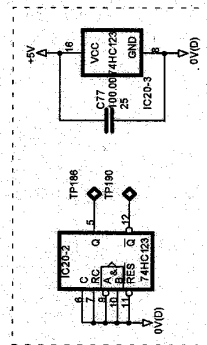
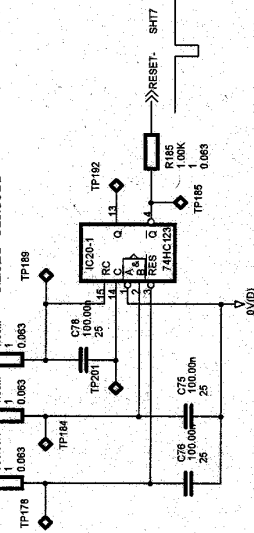

**RESET / NMI / SUPPLY CHECK**

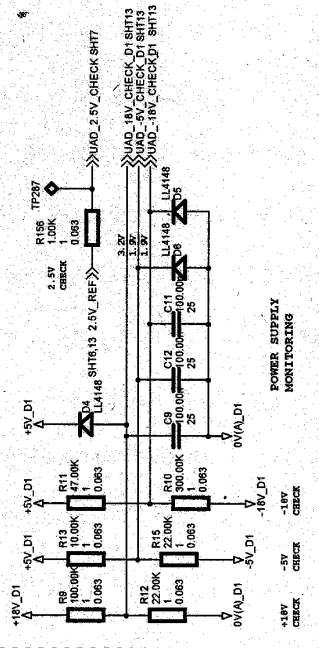

**POWER SUPPLY MONITORING**

SHEET1 - HV INVERTER RANGING  
 SHEET2 - GND / 200VDC  
 SHEET3 - RCD CURRENT CONTROL  
 SHEET4 - LOOP MEASUREMENT  
 SHEET5 - MICROPROCESSOR  
 SHEET6 - MICROPROCESSOR  
 SHEET7 - OUTPUT LATCHES 2,3&5  
 SHEET8 - RESET/PSU MONITORS  
 SHEET9 - POWER SUPPLIES  
 SHEET10 - MEAS TO RLY&DISP CONNS  
 SHEET11 - MEAS TO DGT CONN

**MAIN MEASUREMENT BOARD**

<b>Megger:</b>	MEGER LIMITED	Document Number	6270-272
	1000, GUYTON, ENGLAND		
Part Number:	MFL18014192	Issue:	1
Drawn By:	R.FOSGATE	Date:	03/07/83
Des. Approved:	G. TOTT	Checked:	R. J. SHEPHERD
	MEGER LIMITED	Size:	A3 Sheet 9 of 13

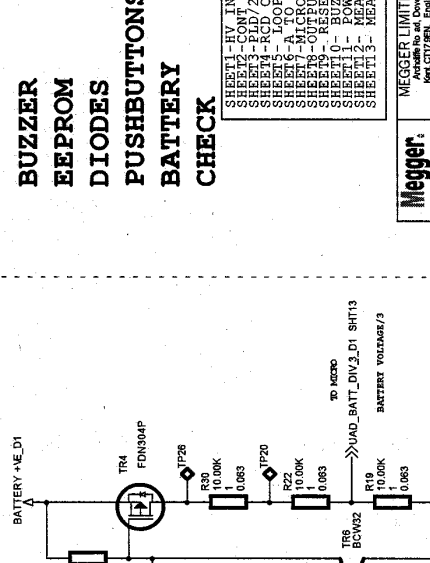
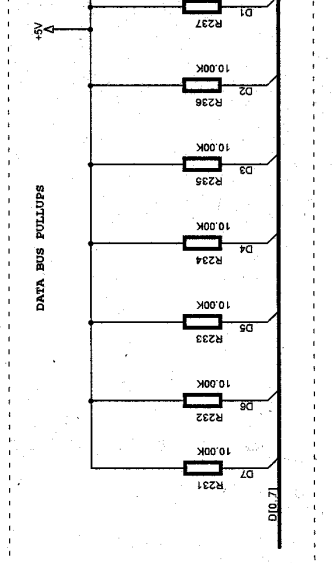
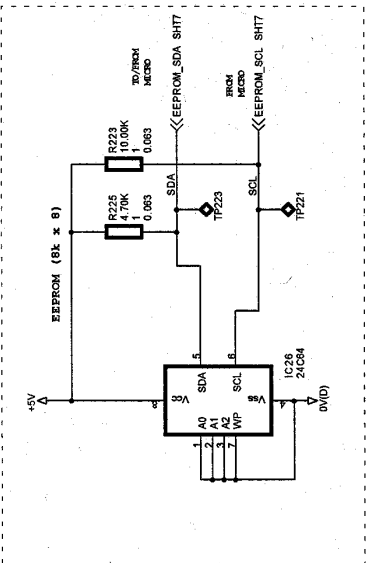
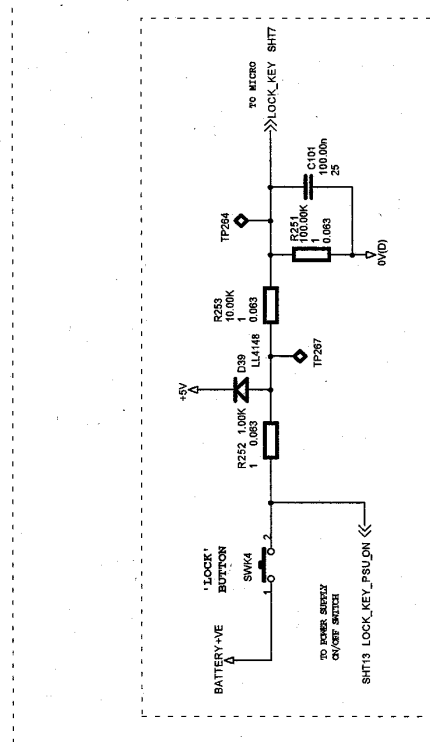
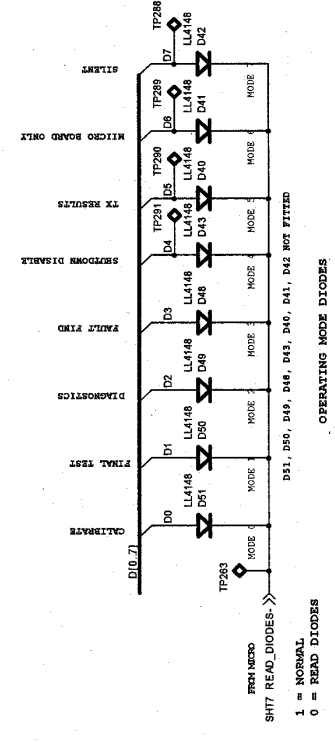
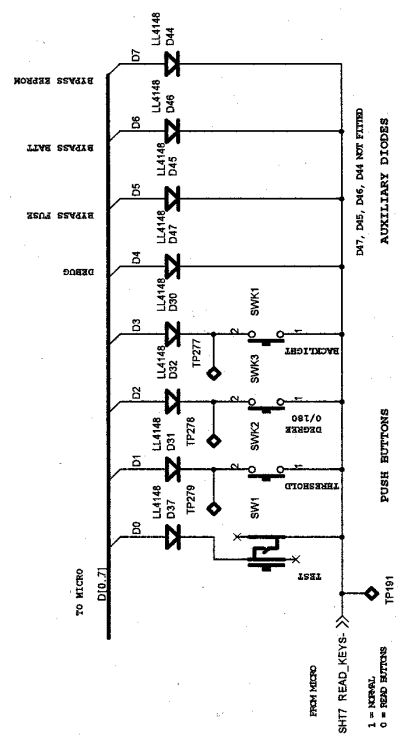

**BUZZER  
EEPROM  
DIODES  
PUSHBUTTONS  
BATTERY  
CHECK**

SHEET1 - RV INVERTER CONTROL  
SHEET2 - LOOP MEASUREMENT  
SHEET3 - CD/2 CURRENT CONTROL  
SHEET4 - LOOP MEASUREMENT  
SHEET5 - MICROPROCESSOR  
SHEET6 - OUTPUT FILTERS  
SHEET7 - RESET/PSU MONITORS  
SHEET8 - POWER SUPPLIES  
SHEET9 - MEAS TO RLY&DISP CONNS  
SHEET10 - MEAS TO DGT CONN

MEGGER LIMITED		Document Number	
MICRO-PE RIPHERAL(EEPROM/DIODES)		6270-272	
DATE	ISSUE	DATE	CN NO.
13/07/03	1	13/07/03	21747
DRAWN BY: ZFJ/SJH		CHKD BY: ZFJ/SJH	
DATE: 13/07/03		REV: 01	
© MEGGER LIMITED		See AS Sheet 10 - 13	

**MAIN MEASUREMENT BOARD**

# DAUGHTER MEASUREMENT BOARD

## POWER SUPPLIES

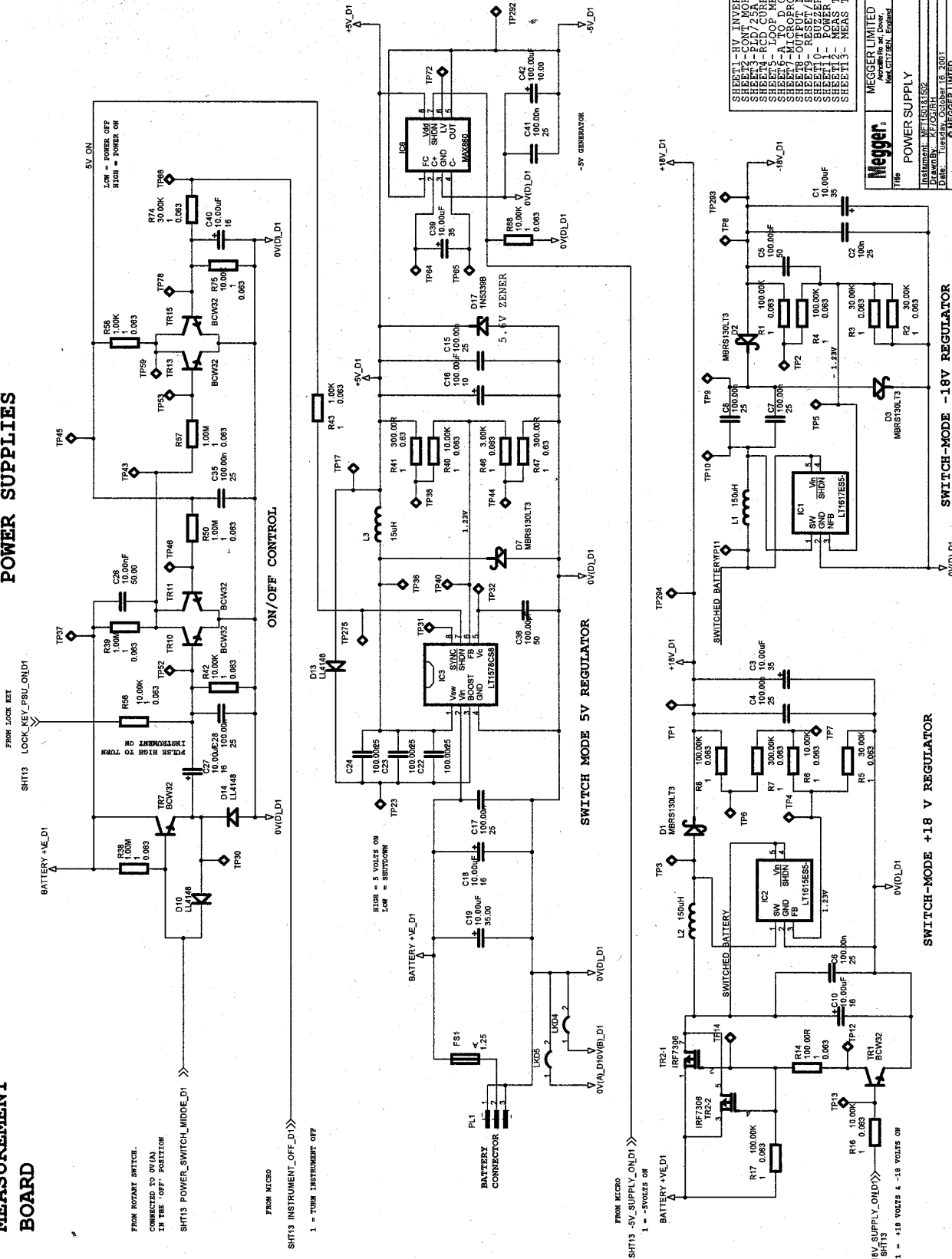

SHEET 1 - HV INVERTER	Document Number	6270-272
SHEET 2 - D17 25A LOOP	Author	W. J. B. / E. W. B.
SHEET 3 - RCD CURRENT CONTROL	Issue	1
SHEET 4 - LOOP MEASUREMENT	Date	03/07/83
SHEET 5 - LOOP PROCESSOR	Inst. No.	21147
SHEET 6 - MICROPROCESSOR	Drawn By	K. J. G. / R. H. J.
SHEET 7 - ALG CROPPING	Check By	W. J. B. / E. W. B.
SHEET 8 - OUTPUT LATCHES - 2, 3, 4, 5	Checked By	W. J. B. / E. W. B.
SHEET 9 - RESET AND MONITOR DIODES	Doc. Title	POWER SUPPLIES
SHEET 10 - POWER SUPPLIES	Doc. No.	6270-272
SHEET 11 - MEAS TO DGT CONNS	Doc. Rev.	1
SHEET 12 - MEAS TO DGT CONN	Doc. Date	11/01/83
SHEET 13 - MEAS TO DGT CONN	Doc. Size	A3
SHEET 14 - MEAS TO DGT CONN	Doc. Sheet	11 of 13

<b>Megger:</b>		Document Number	6270-272
POWER SUPPLY		Issue	1
Instrument: MFT150133502		Date	03/07/83
Drawn By: K. J. G. / R. H. J.		Inst. No.	21147
Check By: W. J. B. / E. W. B.		Doc. Title	POWER SUPPLIES
Checked By: W. J. B. / E. W. B.		Doc. No.	6270-272
Doc. Rev.		Doc. Date	11/01/83
Doc. Size		Doc. Sheet	11 of 13

# MEASUREMENT BOARD/ RELAY BOARD INTERFACE

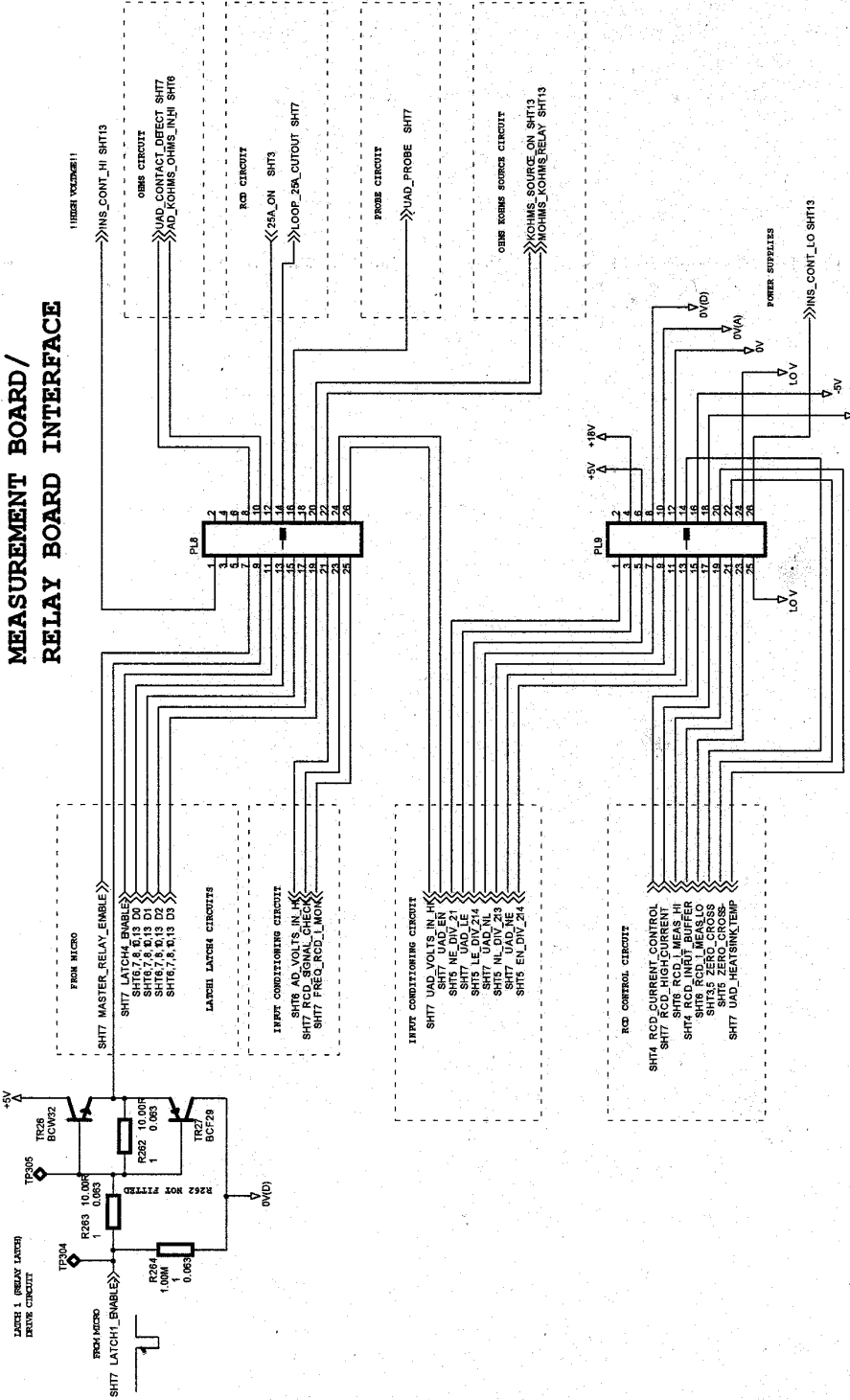

# MEASUREMENT BOARD/ DISPLAY BOARD INTERFACE

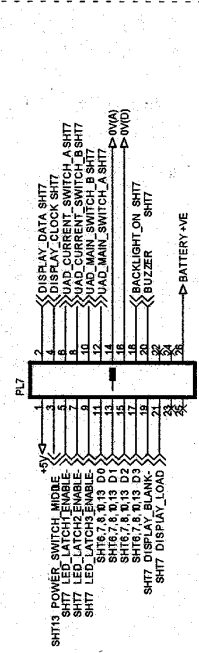

# MAIN MEASUREMENT BOARD

SHEET 1	HY. TAPWATER
SHEET 2	CONT. MOTOR RANGING
SHEET 3	PLD/25A LOOP
SHEET 4	RCD CURRENT CONTROL
SHEET 5	LOOP CONVERTER
SHEET 6	ATC PROCESSOR
SHEET 7	OUTPUT LATCHES 2,3 & 5
SHEET 8	BUZZER/BUZZER ACTION DIODES
SHEET 9	POWER SUPPLIES
SHEET 10	MEAS. TO RLY & DISP. CONNS
SHEET 11	MEAS. TO RLY & DISP. CONNS
SHEET 12	MEAS. TO RLY & DISP. CONNS

<b>Megger:</b>	MEGGER LIMITED	Document Number	6270-272
	West. Div. - Engin.		
Title	up-Relay & up-Display Interfaces		
Drawn by	M.F.H. 5013 B92	Issue	016
Checked by	K.F. 05/88	Issue	1
Drawn by	06/88	Issue	1
Checked by	06/88	Issue	1
Drawn by	06/88	Issue	1
Checked by	06/88	Issue	1



# MEASUREMENT/DAUGHTER BOARD INTERFACE

## MEASUREMENT BOARD

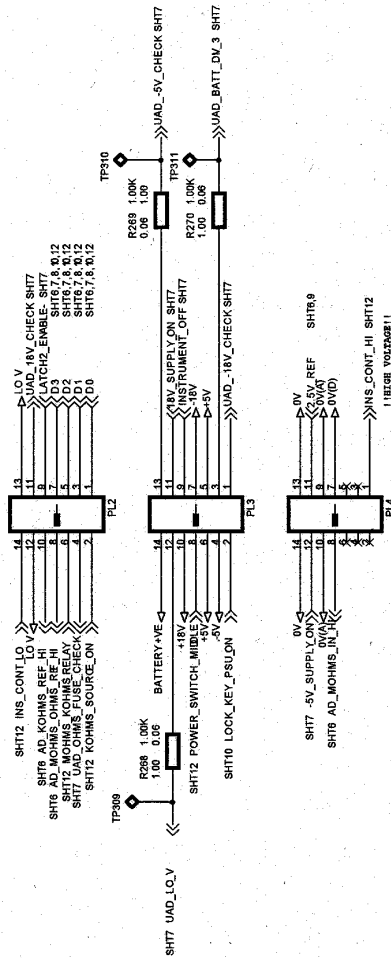

## DAUGHTER BOARD

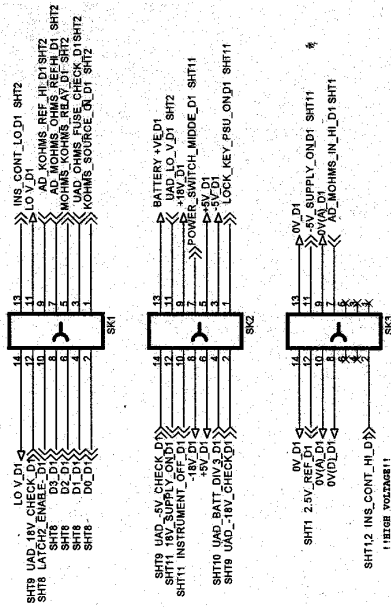

SHEET1	HV INVERTER
SHEET2	CONT MOHMS RANGING
SHEET3	FC/2000 CONTROL
SHEET4	LOOP MEASUREMENT
SHEET5	TO D CONVERTER
SHEET6	OUT PUT LATCHES
SHEET7	RESET/FSU MONITORS
SHEET8	BOARDS FUNCTION DIODES
SHEET9	MEAS TO RL1401SP CONNS
SHEET10	MEAS TO DIGHT CONN
SHEET11	
SHEET12	
SHEET13	

<b>Megger</b>		MEGGER LIMITED		Document Number	
A subsidiary of Dover		Incorporated in England		6270-272	
Title: Daughter PCB INTERFACE					
Instrument	DE11824182	Issue	1	Date	03/07/03
Drawn By	KJOS/ARH	Issue	1	Date	21/7/03
Date	Tuesday, October 18 2001	Issue	1	Date	03/07/03
© MEGGER LIMITED					
Rev: AS1 Suppl: 13 - 01 13					

# 3. Relay CCT

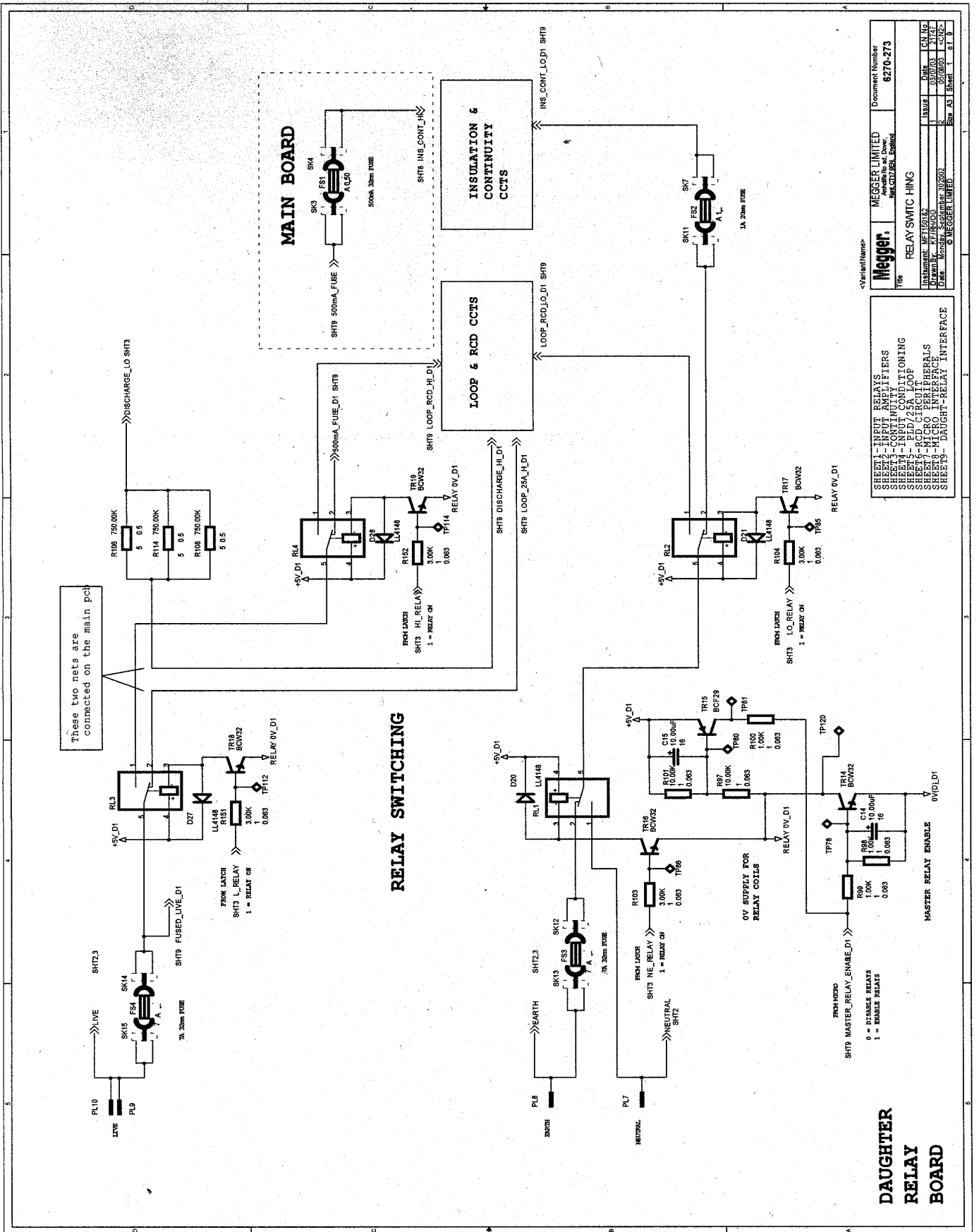

Variant Name: < Variant Name >

MEGGER LIMITED		Document Number	6270-273
Preliminary Drawing			
MEGGER (S&A) Limited			
1786	RELAY SWITC HING		
1	1	1	1
1	1	1	1
1	1	1	1
1	1	1	1
1	1	1	1
1	1	1	1
1	1	1	1
1	1	1	1

SHEET 1 - INPUT RELAYS  
 SHEET 2 - INPUT AMPLIFIERS  
 SHEET 3 - INPUT CONDITIONING  
 SHEET 4 - PID/25A LOOP  
 SHEET 5 - RCD CIRCUIT  
 SHEET 6 - MICRO INTERFACE  
 SHEET 7 - MICRO INTERFACE  
 SHEET 8 - DAUGHTER RELAY INTERFACE  
 SHEET 9 - DAUGHTER RELAY INTERFACE

## DAUGHTER BOARD



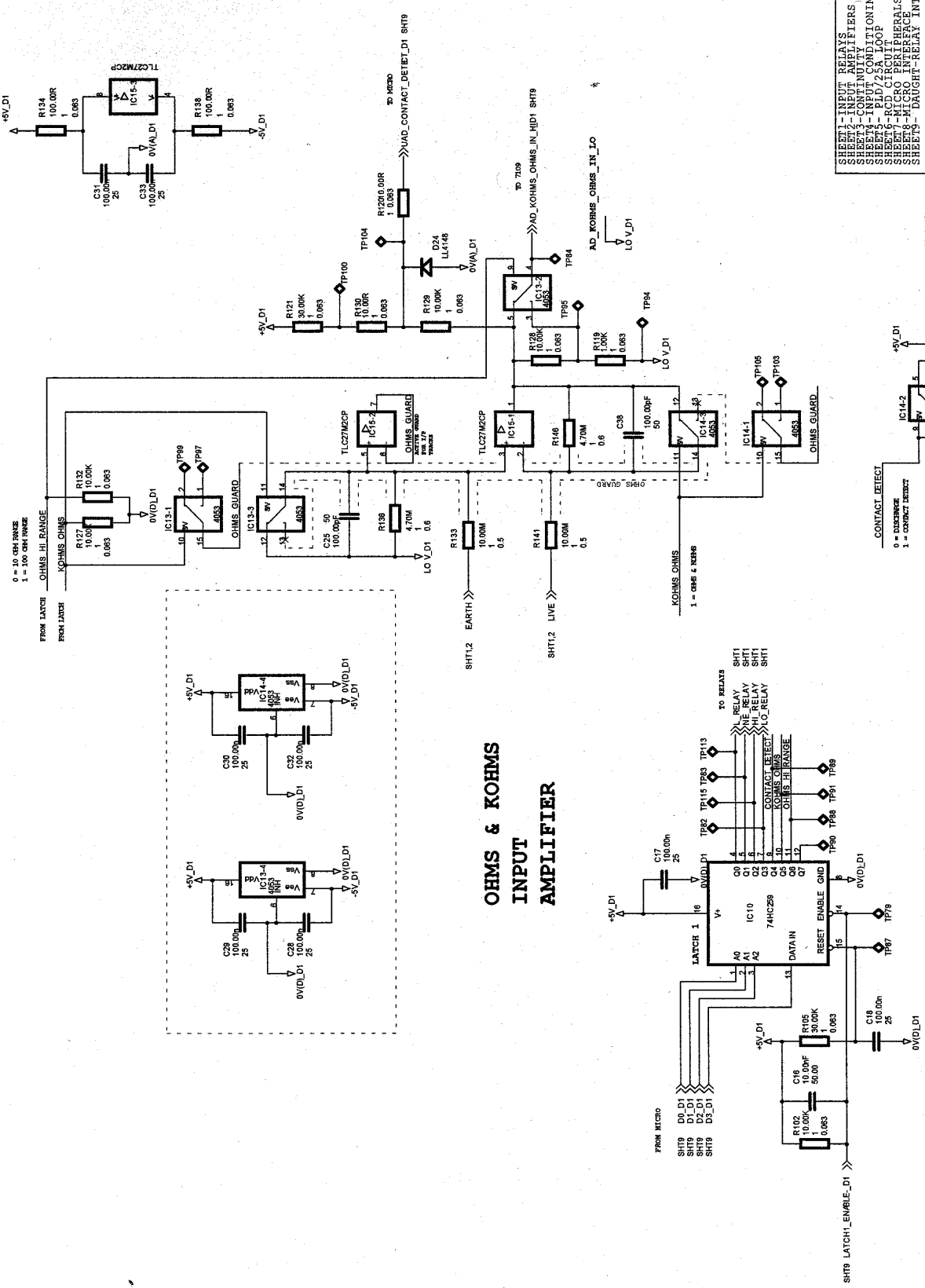

**OHMS & KOHMS  
INPUT  
AMPLIFIER**

SHEET 1 - INPUT RELAYS  
 SHEET 2 - CONTACT DETECT  
 SHEET 3 - INPUT CONDITIONING  
 SHEET 4 - 510/25A LOOP  
 SHEET 5 - MICRO PRTTHERALS  
 SHEET 6 - MICRO PRTTHERALS  
 SHEET 7 - MICRO PRTTHERALS  
 SHEET 8 - MICRO PRTTHERALS  
 SHEET 9 - DAUGHTER-RELAY INTERFACE

MEGGER LIMITED		Document Number	
6270-273		6270-273	
CONTINITY			
Instrument	WT15033	Issue	Date
Drawn By	KZ/BJ/03	1	03/07/03
Date	Monday, September 30, 2002	2	01/08/05
© MEGGER LIMITED		888 AS1 Street 3 0 L 8	

**DAUGHTER  
RELAY  
BOARD**

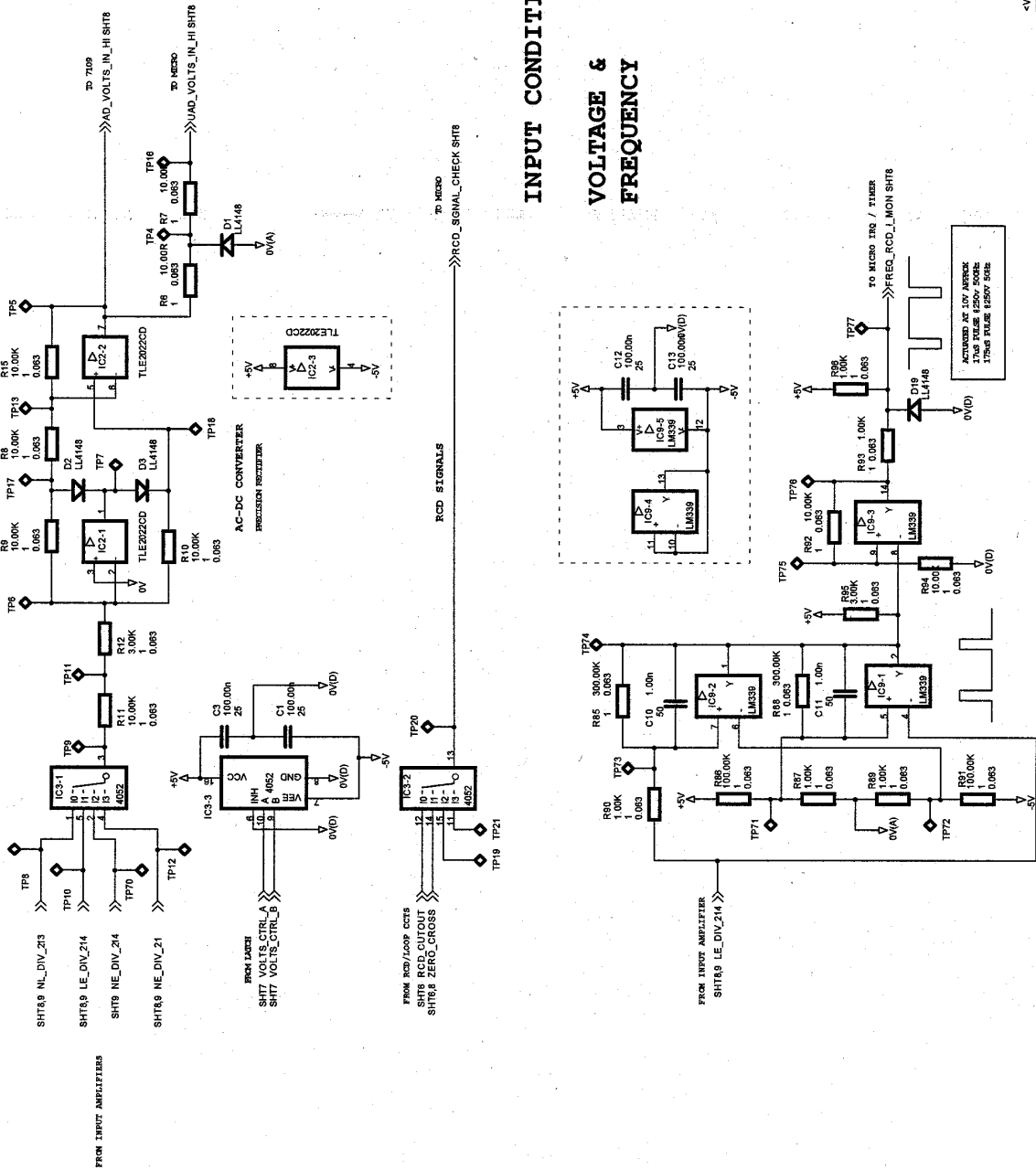

**INPUT CONDITIONING**  
**VOLTAGE & FREQUENCY**

<VariantName>

<b>Megger</b>		Document Number	
NFUTCONDIT ONING		6270-273	
Location: WFT10132	Issue: 1	Date: 05/07/03	Ch. No: 21/21
Drawn By: K.FINLOG	2	05/06/03	1-6292-
Date: Monday, September 30, 2002	2		
© MEGGER LIMITED		Rev. A3	Sheet 4 of 9

- SHEET1-INPUT RELAYS
- SHEET2-INPUT AMPLIFIERS
- SHEET3-INPUT AMPLIFIERS
- SHEET4-INPUT CONDITIONING
- SHEET5-PID/25% LOOP
- SHEET6-RCD CHECK
- SHEET7-RELAY SIGNALS
- SHEET8-MICRO INTERFACE
- SHEET9-DAUGHT-RELAY INTERFACE

**MAIN RELAY BOARD**



# MAIN RELAY BOARD

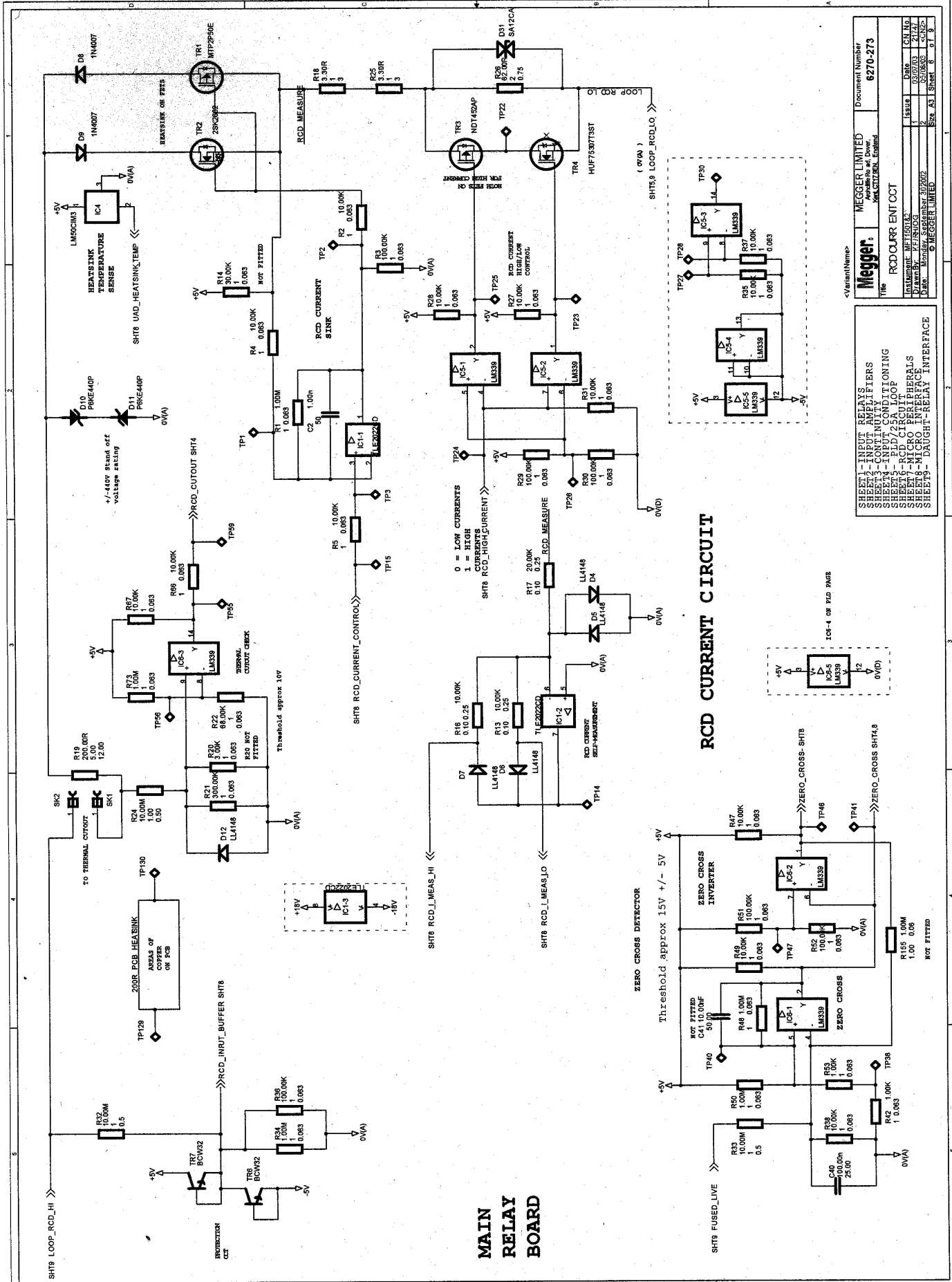

## RCD CURRENT CIRCUIT

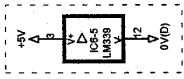
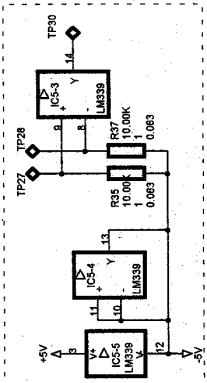

MEGGER LIMITED		Document Number	6270-273
RCD CURRENT CIRC		Date	01/08/93
Title		Issue	2
DRAWN BY: P. J. WOOD		Check No.	01/08/93
CHKD BY: M. J. WOOD		Size	A3 Sheet 6 of 9
DATE: 01/08/93			
Dwg. No. 6270-273			

MEGGER LIMITED		Document Number	6270-273
RCD CURRENT CIRC		Date	01/08/93
Title		Issue	2
DRAWN BY: P. J. WOOD		Check No.	01/08/93
CHKD BY: M. J. WOOD		Size	A3 Sheet 6 of 9
DATE: 01/08/93			
Dwg. No. 6270-273			

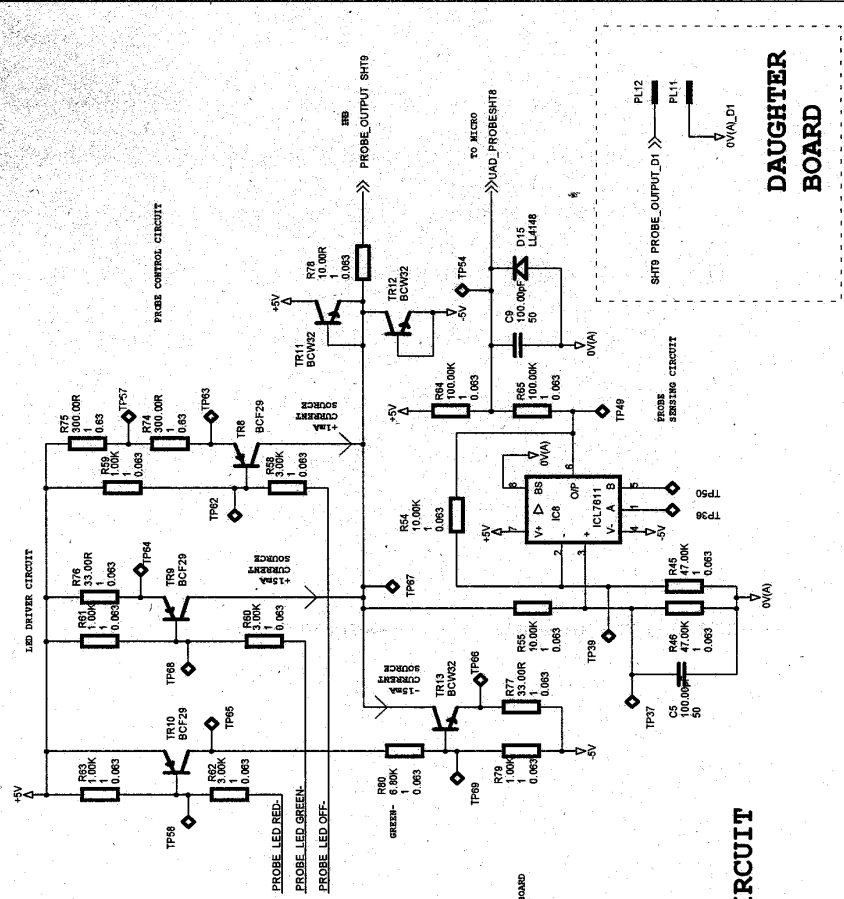

**PROBE CIRCUIT**

RED-	GREEN-	OFF-	ACTION
1	1	1	OFF/ON SENSE
1	1	0	OFF/TB SENSE
0	1	1	RED/TB SENSE
1	0	1	GREEN/TB SENSE

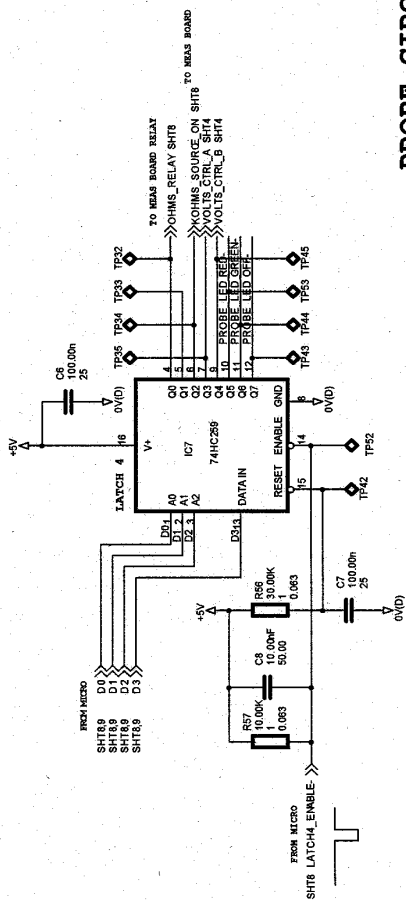

**MAIN RELAY BOARD**

SHEET 1 - INPUT RELAYS  
 SHEET 2 - INPUT AMPLIFIERS  
 SHEET 3 - INPUT CONDITIONING  
 SHEET 4 - PLD/75A LOOP  
 SHEET 5 - ACD CIRCUITRY  
 SHEET 6 - MICRO INTERFACES  
 SHEET 7 - MICRO INTERFACES  
 SHEET 8 - DAUGHTER-RELAY INTERFACE

<VariantName>  
**Megger**  
 MEGGER LIMITED  
 Parkside Rd. Dover, Kent, UK  
 Document Number  
**6270-273**  
 Title  
**PROBE CIRCUIT**  
 Instrument: ME17032  
 Drawing: K2/REV03  
 Date: Monday, September 30/2002  
 Issue: 2  
 Date: 03/07/03  
 ON No: 2124  
 C/N: 2  
 See AS1 Sheet 7 of 8



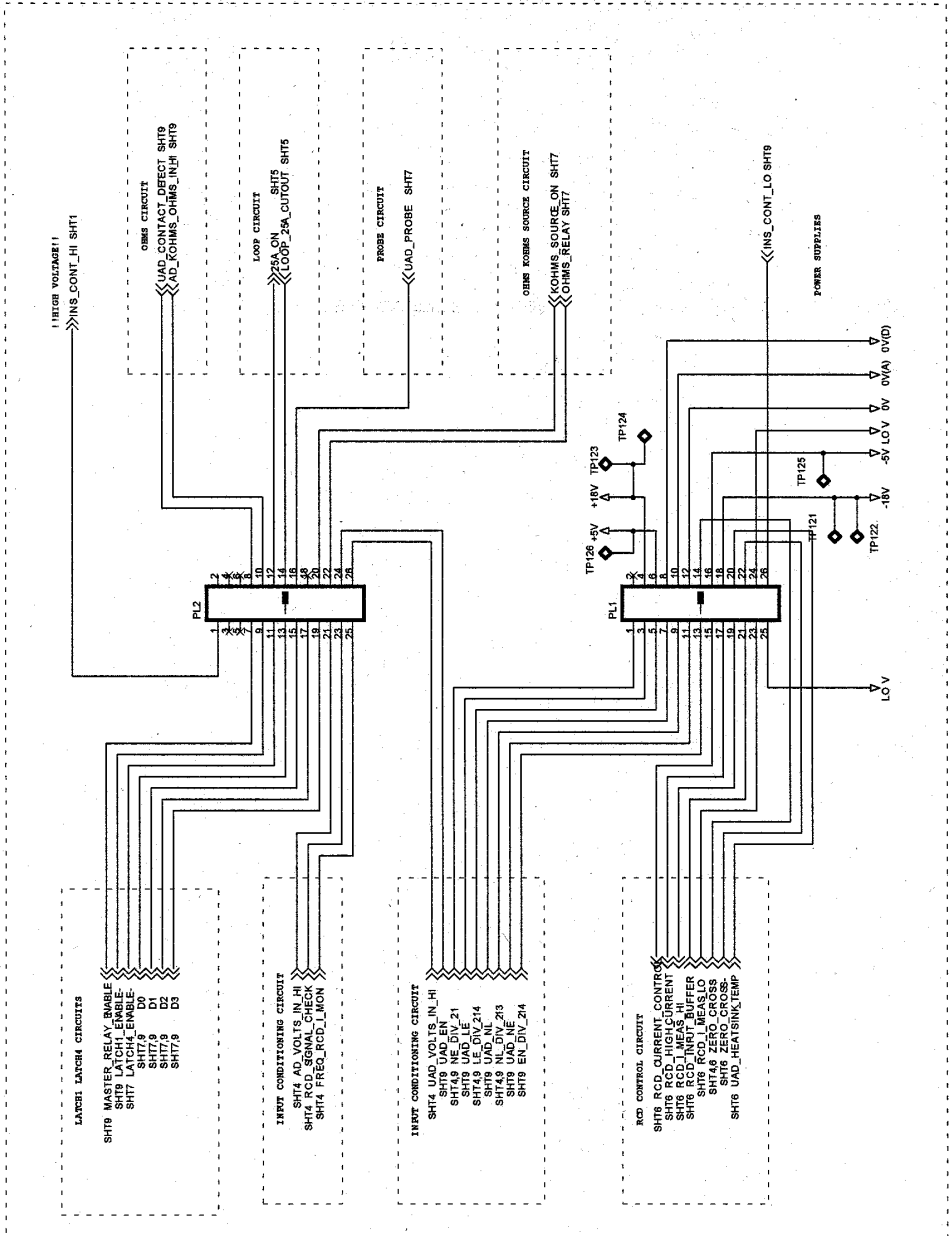

**RELAY BOARD /  
MEASUREMENT BOARD  
INTERFACE**

VariantName: <VariantName>

MEGGER LIMITED		Document Number	6270-273
P.O. Box 100, 10000, 10000, 10000		Revision	01/0003
MICROINTERFA CE		Issue	01/0003
Drawn By: KJ/RL/09	Checked By: KJ/RL/09	Issue	01/0003
Date: Monday, September 30 2002	Time: 10:00:00	Issue	01/0003
© MEGGER LIMITED		Rev. A31 Sheet	8 of 8

SHEET 1 - INPUT RELAYS  
SHEET 2 - INPUT AMPLIFIERS  
SHEET 3 - INPUT CONDITIONING  
SHEET 4 - LOOP AMPLIFICATION  
SHEET 5 - RLD/25A LOOP  
SHEET 6 - RCD CIRCUIT  
SHEET 7 - MICRO INTERFACES  
SHEET 8 - MICRO INTERFACES  
SHEET 9 - DAUGHTER-RELAY INTERFACE

**MAIN  
RELAY  
BOARD**





**Appendix 3 PCB Layout Drawings**  
**1. Display PCB**

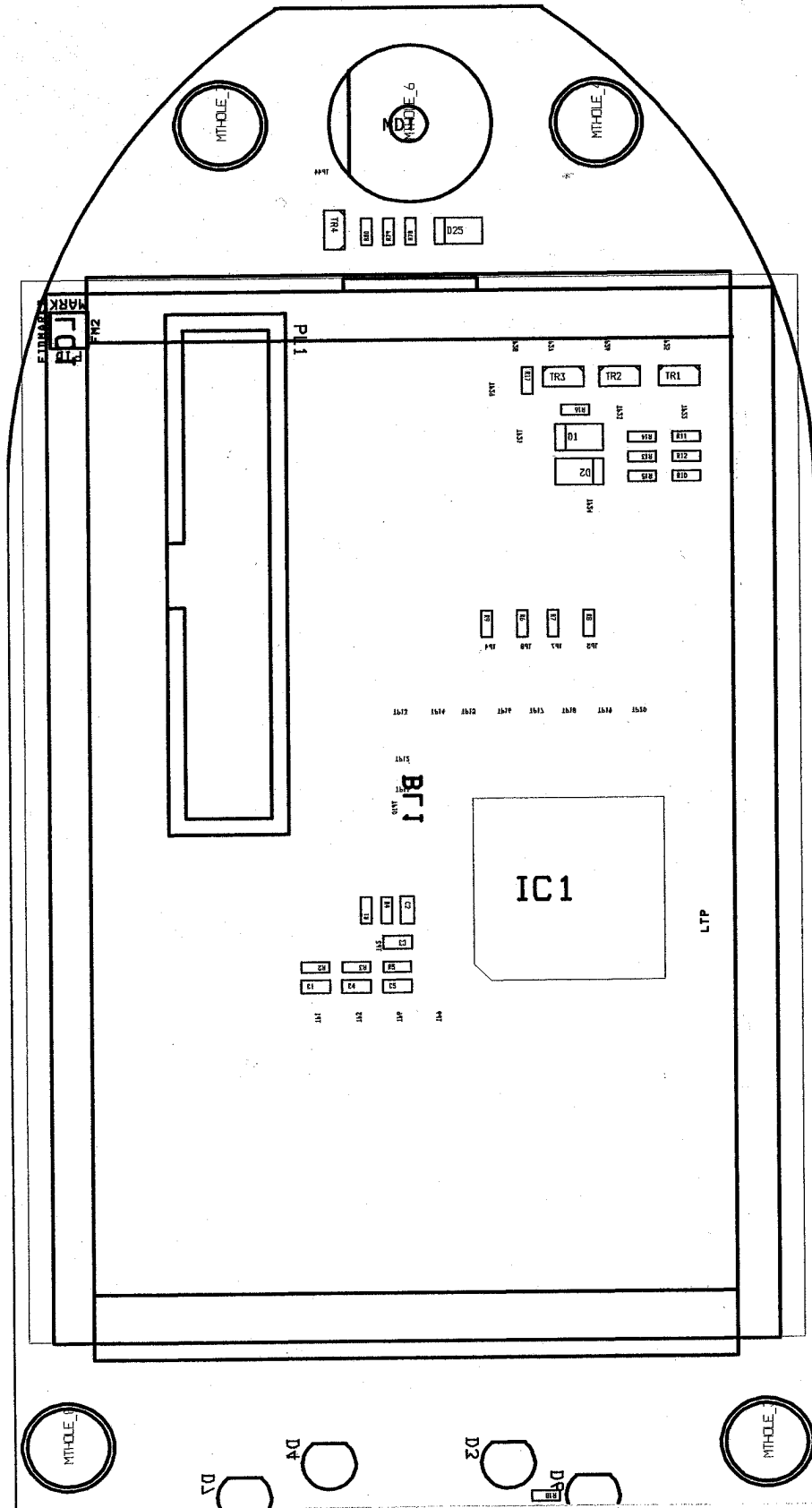

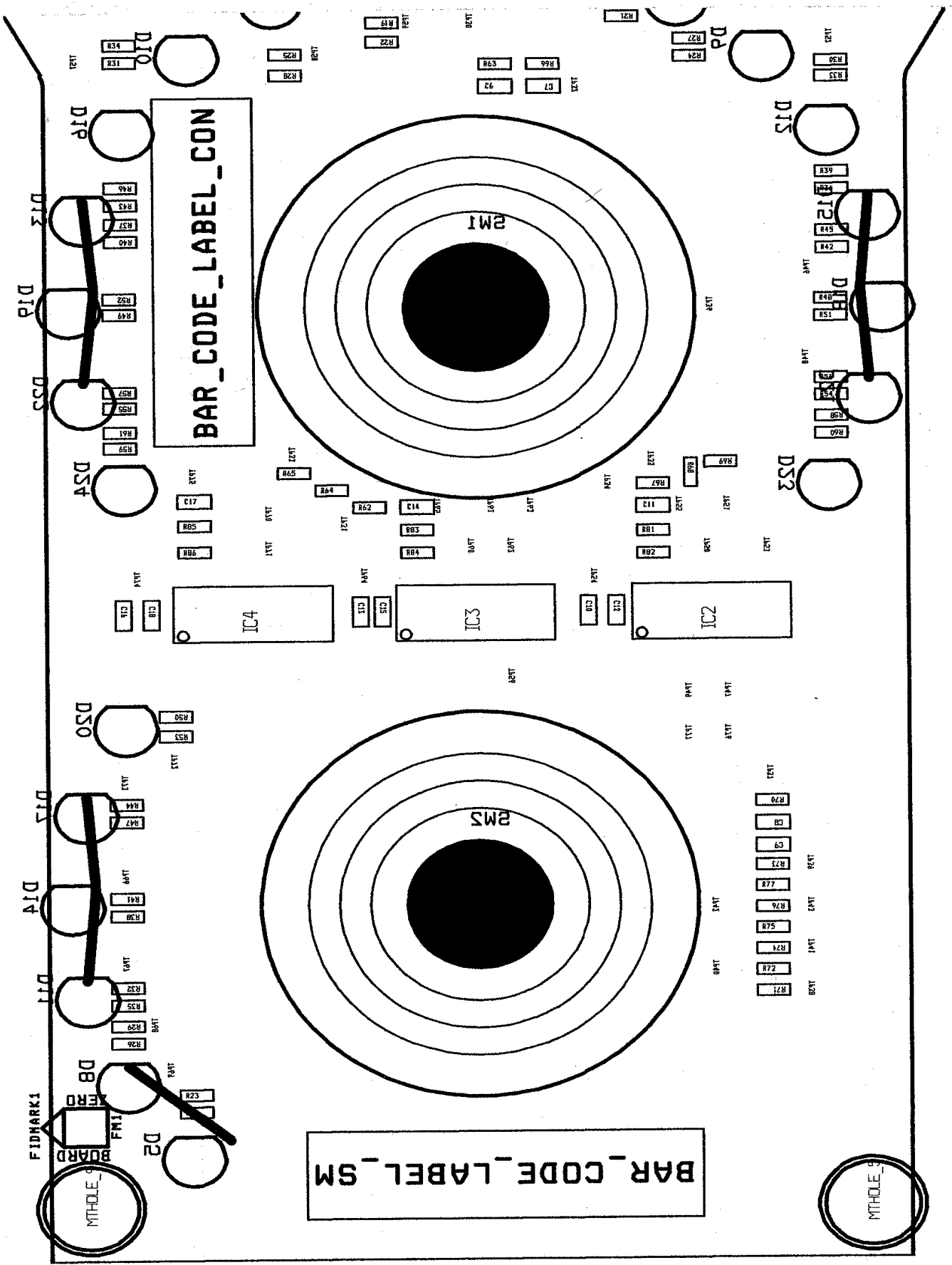

## 2. Measurement PCB

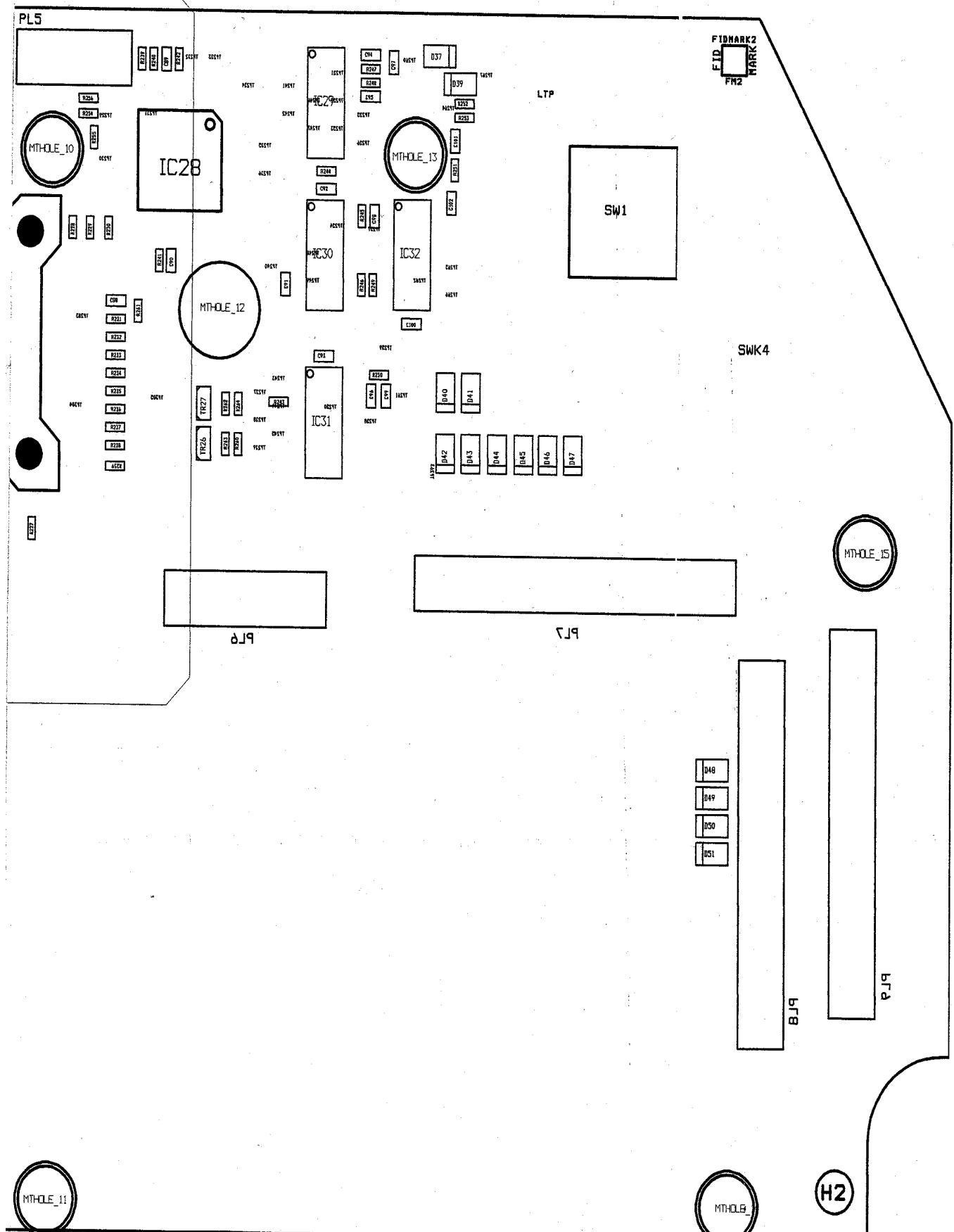

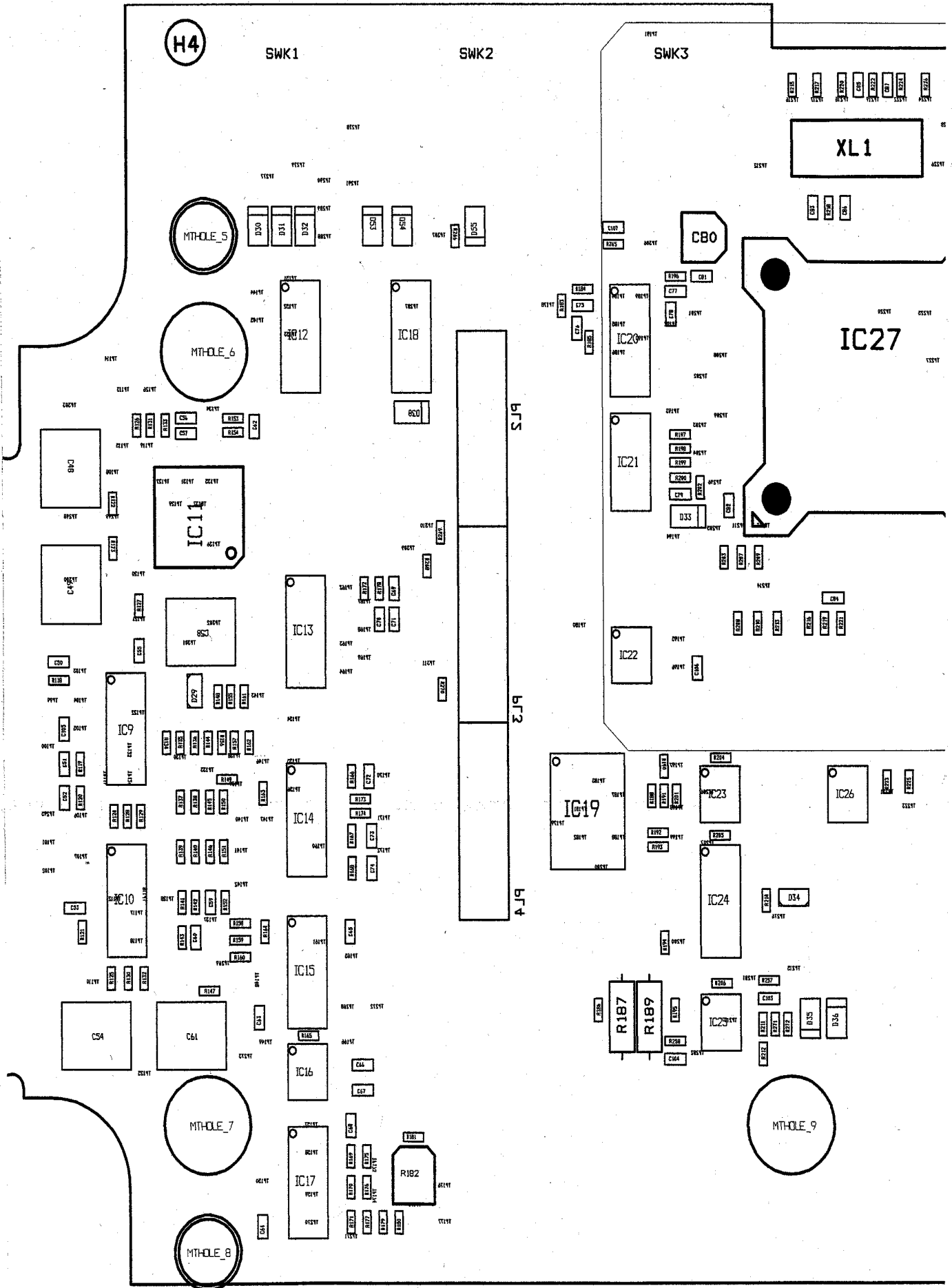

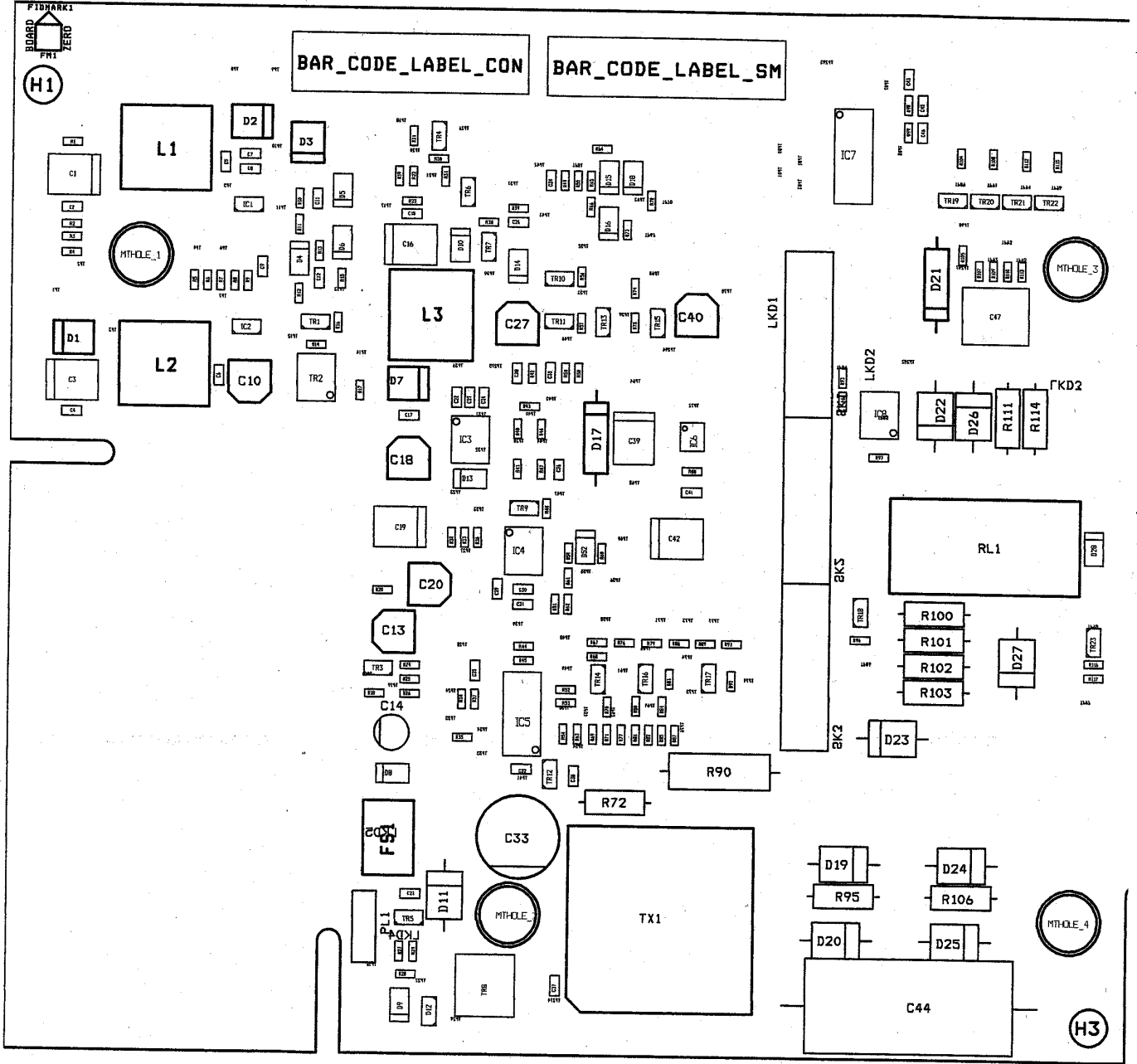



### 3. Relay PCB

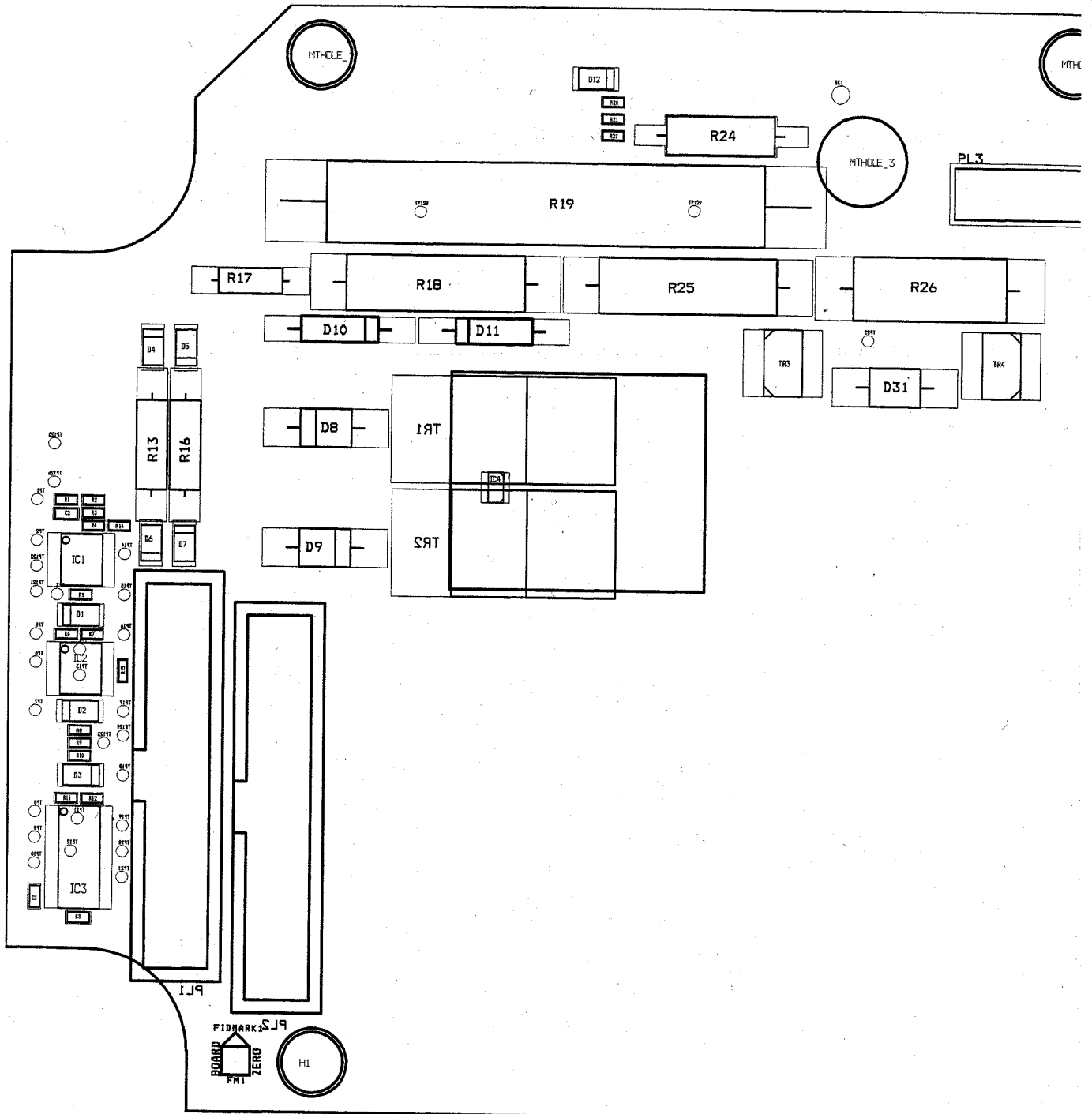

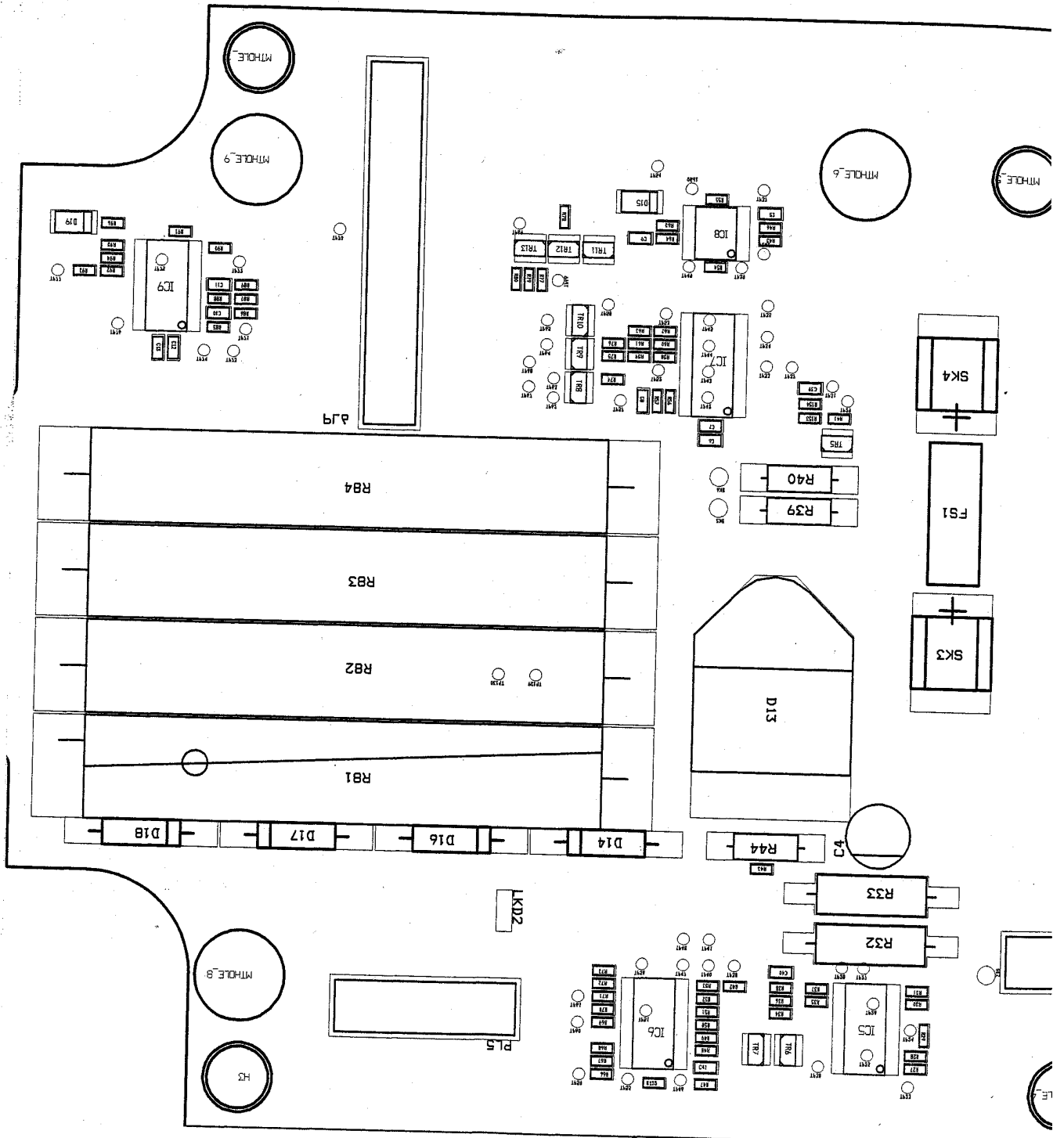

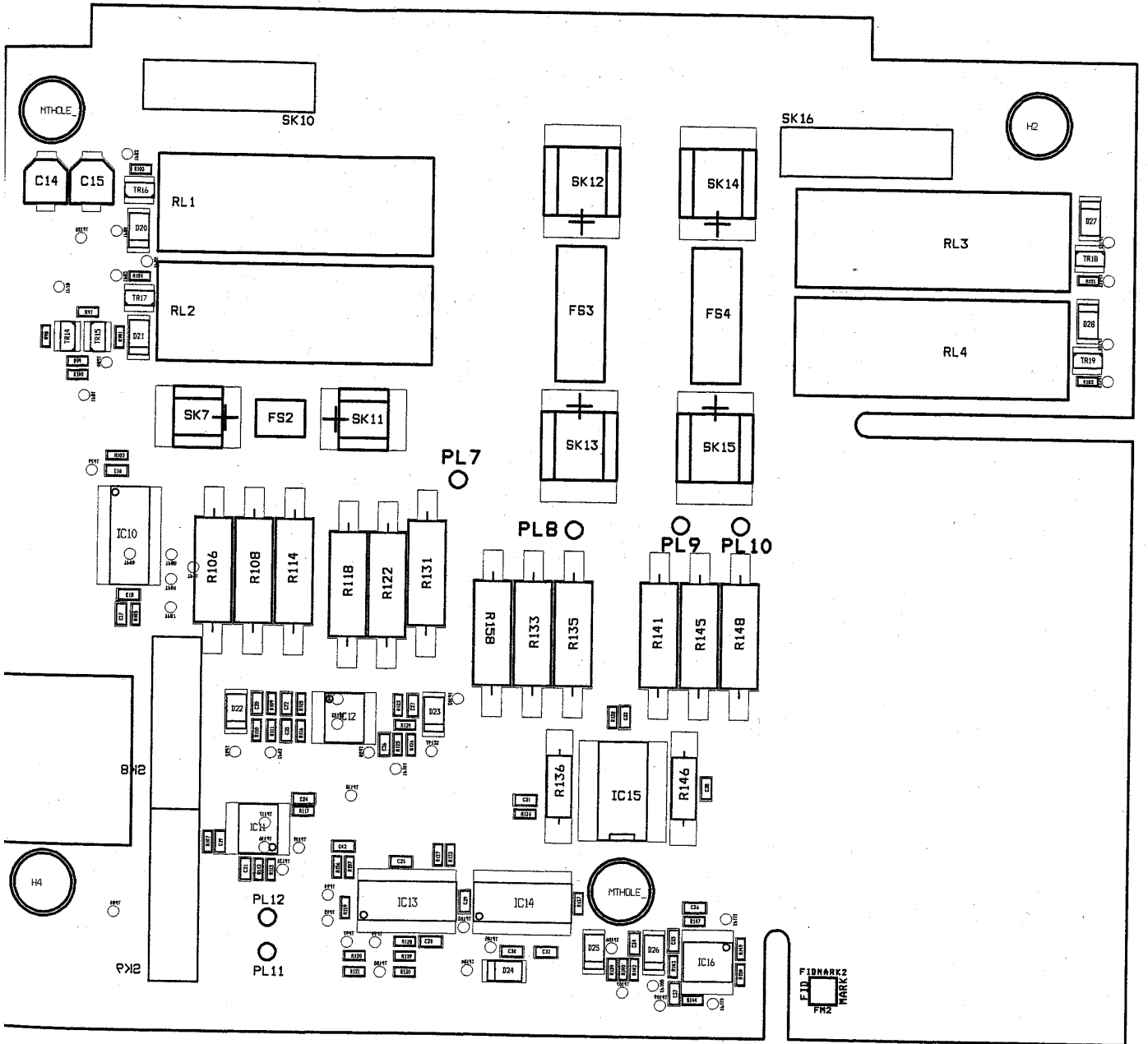

## **Appendix 4 Calibration**

### **1. General Description**

Calibration is only possible when the instrument has been put into Calibrate Mode. This can be done in several ways - see the Appendices.

Most of the setting-up can be done on the fully assembled instrument, using the normal instrument controls. For example, if the 'lock' button is pressed during a test, this sets up a 'calibrate-request', which will be serviced when the instrument calculates the next result.

If a calibration is successful, a high frequency beep is sounded, and a 'cal' message is sent out on the serial link. If not, a longer lower-pitched warning beep is issued, and the display is briefly blanked out.

Calibration is also possible by remote control from a pc. For details, see the Appendices.

### **2. Calibration Constants**

If a test result is calculated using the nominal values of the circuit components, then the answer should be nearly correct, but will be in error by up to a few percent due to tolerances etc. Thus a correction factor near to unity can be applied to bring the result back to full accuracy. These adjustments are calculated in response to calibrate-requests, and stored in non-volatile memory. The convention adopted is as follows...

$$\text{Calibration constant} = (\text{Measured Result})/(\text{Expected Result})$$

### **3. Intelligent Calibration**

The calibration constants are grouped in ways which reflects the design of the hardware. For example, on Insulation Test, there is a set of 4 constants for calibration points on the 4 resistance measurement ranges, and a set of 3 constants relating to the 3 output voltages. The calibration system is designed to be as flexible as possible, so that a minimum amount of setting up is required for standard calibration, but there is still the option for more accuracy if desired. This is to cope with any future problems or new requirements. For example, a basic set-up on insulation would be to calibrate one measurement point only. To achieve a tighter specification, every calibration point could be adjusted. The MFT automatically decides which point is being set-up, according to the load.

## **4. RCD/ Loop 25A/No Trip Loop Calibration**

### **4.1 Calibration of RCD Current**

Due to limitations in the RCD current source it is necessary to calibrate nearly all of the RCD currents individually. Particularly at low currents zero crossing distortion of the current waveform makes the current set up rather non linear. The final currents are calculated to be either 5% higher or lower than the nominal current depending whether the test is a trip test or not (trip tests are high, non trip tests are low).

The calibration should be performed using a stabilised low impedance supply (at 230V 50Hz). Each current point is calibrated in turn, starting with the lowest and finishing with the highest. The current points are as follows (5mA, 10mA, 15mA, 30mA, 50mA, 100mA, 150mA, 250mA, 300mA, 500mA, 1000mA). Unlike the LCB the RCD current points are calibrated at their nominal values rather than the final values used in customer mode.

The calibration is accomplished by externally measuring the nominal current and then applying a correction to the instrument in the form of a required number of predefined current steps. The corrected current is checked after adjustment and, if acceptable, the value is stored to the Eeprom. The instrument uses a long test (1 second) when in calibrate and final test modes – to permit the external current measurement device to capture the current accurately.

## **4.2 Calibration of Loop Measurement**

There are three ranges within the Loop measurement section of the MFT1501/2 – these are 25A, NO TRIP and PSC. The measurement procedure is essentially identical for 25A and PSC ranges – the answer is just expressed in a different form. The NO TRIP range uses a technique based on the LT7 3 wire test. The NO TRIP range relies on the RCD currents having been adequately set up and also requires that the 25A range has been calibrated. The calibration also requires that a stabilized 230V 50Hz supply is used (this must be capable of supplying 25A). A hardware calibration also must be performed on the two armed circuit – this is usually carried out at board test, but can be performed later on a disassembled instrument – the pot R182 must be set up to balance the two armed circuit. To calibrate the balance pot, the instrument must be in calibrate mode, select the RCD ramp test, apply mains voltage between Live and Earth, then press the Test button. The instrument display should show a digital readout and a ‘centre zero’ analogue pointer – adjust the pot R182 to get the pointer as close to the centre point as possible (a reading within ? 10 is OK). To exit the calibration, press the lock key.

### 4.2.1 25A test

The 25A test contains in effect two tests :-

The first is used for low loop resistances (under 20 ohms) and is the true 25A test.

The second is a test using the RCD current source.

In the true 25A test, the errors from tolerances come from two sources. The first being errors in the  $V_D$  measurement (the output of the two armed circuit). The second being caused by the tolerance of the 9.6 ohm load. The RCD current based test is only affected by the  $V_D$  error.

The first calibration is of the  $V_D$  error – the  $V_D$  error is isolated by doing the test using the calibrated RCD current source (with a loop resistance of nominally 1k ohm). The calibration of the 9.6 ohms error is subsequently carried out using a lower impedance loop (typically 10 ohms). The measurement offset is calibrated using a loop resistance close to zero. To avoid using ‘magic numbers’ in the code the calibration is achieved by adjusting the result from the instrument up or down to the target value prior to using the lock key to store the result. The RCD current based loop measurement may be performed at one of three RCD currents (15mA, 50mA, 250mA) depending on the loop resistance.

#### **Minimum set-up**

Select 25A Loop test range.

Apply 1k ohms load.

Press the test button.

Adjust the result displayed using the degree and/or threshold buttons.

Press the lock button.

Apply 10 ohms load.

Press the test button.

Adjust the result displayed using the degree and/or threshold buttons.

Press the lock button.

Apply 0.1 ohms load.

Press the test button.

Adjust the result displayed using the degree and/or threshold buttons.

Press the lock button.

### Full set-up

Carry out the minimum setup above, plus...

Apply 90 ohms load.

Adjust the result displayed using the degree and/or threshold buttons.

Press the lock button.

Apply 160 ohms load.

Adjust the result displayed using the degree and/or threshold buttons.

Press the lock button.

### 4.2.2 No Trip test

The No Trip test uses two methods to measure the Line Earth loop resistance. For high resistances, the two wire RCD type test is used (at 15mA) – this has already been calibrated in the 25A section above. The low resistances are measured using the three wire technique – ( $R_{live} + R_{neutral}$ ) is measured by passing 25A current between Live and Neutral, then the test is repeated measuring the voltage across  $R_{neutral}$  and the value of  $R_{neutral}$  is calculated.  $R_{live}$  is deduced by subtracting  $R_{neutral}$  from the total ( $R_{live} + R_{neutral}$ ).  $R_{earth}$  is calculated from the average of many filtered measurements of the (small) Neutral – Earth voltage while passing 15mA between Live and Earth.

#### Full set-up

Select NO TRIP Loop test range.

Apply 0 ohms load ( $RL=0.1, RN=0, RE=0$ ).

Press the test button.

Adjust the RL result displayed using the degree and/or threshold buttons.

Press the lock button.

Adjust the RE result displayed using the degree and/or threshold buttons.

Press the lock button.

Adjust the RN result displayed using the degree and/or threshold buttons.

Press the lock button.

Apply 10 ohms RE load.

Press the test button.

Adjust the RE result displayed using the degree and/or threshold buttons.

Press the lock button.

Apply 10 ohms RN load.

Press the test button.

Adjust the RN result displayed using the degree and/or threshold buttons.

Press the lock button.

Apply 10 ohms RL load.

Press the test button.

Adjust the RL result displayed using the degree and/or threshold buttons.

Press the lock button.

Apply 0 ohms load ( $RL=0.1, RN=0, RE=0$ ).

Press the test button.

Adjust the RL result displayed using the degree and/or threshold buttons.

Press the lock button.

Adjust the RE result displayed using the degree and/or threshold buttons.

Press the lock button.

Adjust the RN result displayed using the degree and/or threshold buttons.

Press the lock button.

## **5. Calibration of Voltage / Pretest / Insulation / Continuity**

### **5.1 Calibration of Voltage Measurement**

#### 5.1.1 Voltage Range

In calibrate mode, the displayed result is always the L-E voltage & this voltage is the only one which can be calibrated. The intelligent calibration system means that the L-N results and the N-E results will be given the same correction factor and will be nominally correct.

The volts range calibration can be done at 50V, 230V, or 400V a.c. or d.c., but normally 230V 50Hz is used. The MFT automatically chooses the appropriate point, according to what voltage is being applied.

Typical set-up

Select the voltage range.  
Apply 230V 50Hz between the L & E terminals.  
Press the lock button.

#### 5.1.2 Pre-test

There are 3 pre-test voltages to be calibrated, i.e. L-N, L-E and N-E.

The L-E voltage is calibrated in the 500V insulation test switch position.

The L-N, and N-E voltages can be calibrated in the 1000V and 250V insulation test switch positions respectively, if required.

The calibration can be done at 50V, 230V, or 400V a.c. or d.c., but normally 230V 50Hz is used. The MFT automatically chooses the appropriate point, according to what voltage is being applied.

Typical set-up

Select 500V insulation position.  
Apply 230V 50Hz between the L & E terminals.  
Press the lock button.

### **5.2 Calibration of Ohms (& kilohms)**

#### 5.2.1 Input Amplifier Offset Correction

The first item which requires setting-up is the offset null of amplifier IC15-1, (relay board sheet 3). If the instrument is in calibrate mode, this offset is measured automatically when 'contact' is detected for the first time. The result is stored in EEPROM, and taken into account in all subsequent ohms measurements. Ideally, the initial contact should be with a low-value resistance, as close to a short circuit as possible.

#### 5.2.2 Ohms Zero Correction

The ohms zero reading is that which occurs with a dead short circuit directly on the instrument terminals. This is determined by pcb layout and tracking within the instrument. The zero reading can be adjusted, if required, by pressing the 'degree' button repeatedly until zero is displayed. The instrument must be in calibrate mode, and the uncorrected reading must be <0.3 ohms. The correction is stored in EEPROM. The zero correction has not been required so far.



### 5.2.3 Range calibration

The lead null must be set before the rest of the calibration can be carried out.

There are calibration points at 5ohms & 50ohms on the 'ohms' ranges, and 500ohms, 5kohms & 50kohms on the 'kilohms' ranges, so these are the resistance values which can be used for calibration. The MFT automatically chooses the appropriate point(s), according to what load is applied. Normally, only 5ohms and 5kohms are used

#### Typical set-up

Apply a short circuit between the L & E terminals.  
Press the test button to set the null.

Apply 5ohms load.  
Press the lock button.

Apply 5kohms load.  
Press the lock button.

### **5.3 Calibration of Megohms Measurement**

There are calibration points at 500kohms, 5Mohms, 50Mohms and 500Mohms, so these are the resistance values which can be used for calibration. The MFT automatically chooses the appropriate point(s), according to what load is applied. Normally only 5Mohms is used.

Typical set-up

Select 500V insulation test range.  
Apply 5Mohms load.  
Press the test button.  
Press the lock button.

Select 250V insulation test range.  
Press the test button.  
Press the lock button.

Select 1000V insulation test range.  
Press the test button.  
Press the lock button.

### **6. Decalibration**

To reset *all* the calibration constants to their default values, the instrument must be fitted with the diode D53 (measurement board), so that it is in calibration mode during start-up. Switch on the MFT, and hold down the 'lock' button and the 'degree' button until the start-up sequence has finished. The MFT displays 'dEC' to confirm. To reset all the variables, (buzzer settings, ohms zero etc.), hold down the 'lock' button and the 'threshold' button during startup. The display shows 'CLr'. These operations cannot be done in remote mode.

To reset a *single* calibration constant, D53 need not be fitted, but the instrument must be in calibrate mode. Proceed as for calibration. Apply a load so as to get the instrument on the desired range, and then hold down the 'backlight' button while pressing the 'lock' button as usual. The MFT responds with a high pitched beep, and a 'decal' message is transmitted on the serial link.

Note that when de-calibrating the 10ohm range on ohms, the ohms zero correction and the input amplifier offset correction are cleared as well.

## Appendix 5 Test Specifications

### 1. Calibration Test Specification 6172-852

Test Equipment

Battery connector

Stabilized AC Power Supply (Chroma)

AC/DC Voltage Source (Rotek)

Multi-function Test Box consisting of...

*Battery Box*

*Volts Box*

*Continuity/Insulation Box*

*RCD Box*

*Loop Box*

The calibration of the instrument will be done at Final test in the MFT1500 cell .

**The sequence of events for the manual calibration will be as follows:**

Connect the remote battery pack to the UUT (the battery voltage should be set to 12V unless otherwise stated)

Connect the UUT to Test jig

Put the UUT into **Calibrate mode** by using the PC, or by means of the front panel controls as follows:

Select the **5I 1000mA** rcd test while pressing the yellow test button and the orange threshold button.

The instrument displays 'CUS' (customer mode).

Press any button to select 'CAL' (calibrate mode).

Turn the rotary switch quickly through OFF, to the Volts position.

(The instrument briefly displays 'SET' to confirm that the new mode has been set)

As each calibration point is locked, the UUT should acknowledge with one or more high-pitched beeps.

**Ignore any calibration steps which are printed in light grey. These items are held in reserve.**

Voltage Calibration

**Connect the UUT test lead to the Volts test box.**

**Use the Rotek as the voltage source.**

Set Battery = 12.0V

UUT RANGE	APPLY	COMMENTS	ACTION
<b>V</b>	230V 50Hz (L-PE)	Wait for reading	Press Lock Button
250V M?	230V 50Hz(N-E)	Wait for reading	Press Lock Button
<b>500V M?</b>	230V 50Hz(L-E)	Wait for reading	Press Lock Button
1000V M?	230V 50Hz(L-N)	Wait for reading	Press Lock Button

**Insulation Calibration**

**Connect the UUT test lead to the Ohms/Insulation test box.**

Set Battery = 12.0V

(Note that the warning triangle flashes during MΩ tests to indicate that a test is in progress)

UUT RANGE	APPLY	COMMENTS	ACTION
500V M?	500K?	Press Test Button, Wait for reading	Press Lock Button
<b>500V M?</b>	<b>5M?</b>	<b>Press Test Button, Wait for reading</b>	<b>Press Lock Button</b>
500V M?	50M?	Press Test Button, Wait for reading	Press Lock Button
500V M?	500M?	Press Test Button, Wait for reading	Press Lock Button
<b>1000V M?</b>	<b>5M?</b>	<b>Press Test Button, Wait for reading</b>	<b>Press Lock Button</b>
<b>250V M?</b>	<b>5M?</b>	<b>Press Test Button, Wait for reading</b>	<b>Press Lock Button</b>
?	0?	Wait for reading	Press Test Button to zero
?	5?	Wait for reading	Press Lock Button
?	50?	Wait for reading	Press Lock Button
?	500?	Wait for reading	Press Lock Button
?	5k?	Wait for reading	Press Lock Button
?	50k?	Wait for reading	Press Lock Button

## RCD Calibration

**Connect the UUT test lead to the RCD test box.**

**Use the Chroma as the power source (set to 230V 50Hz)**

Set Battery = 12.0V

### RCD current setup

NB The RCD current setup is dependant on the supply voltage (Live-Earth) remaining at a constant 230V – so ensure that a stabilized supply is used.

Switch the UUT to the RCD range and select the appropriate current setting (e.g. for 5mA select 1/2I and 10mA). Where there is more than one combination of switch settings that produce the same current it doesn't matter which is chosen (e.g. 500mA can be calibrated with 1/2I 1000mA , I 500mA or 5I 100mA).

In Calibrate and Final test modes the RCD tests will automatically run for two seconds to make measurement easier.

Pressing the Test button starts the test allowing the existing calibrated current to be measured.

If the current needs to be adjusted, this is achieved by repeatedly pressing the degree or threshold button to 'nudge' the current towards the target. The current may be increased by pressing the Degree Button, or decreased by pressing the Threshold Button. Each press of the Degree or Threshold button alters the current by a fixed step size allowing the number of button presses required to be calculated after the current is first measured. To save overheating the RCD circuit the adjusted current will only be generated when the test button is pressed again (to allow the adjusted current to be verified).

When the current is as close as possible to the desired setting press the Lock Button to store the setting to Eeprom. If a thermal trip occurs during calibration the message 'Hot' will appear on the display.

UUT RANGE	STEP SIZE(mA)	VALUE(on RCD test box)	COMMENTS	ACTION
-----------	---------------	------------------------	----------	--------

Switch the UUT to the appropriate RCD range.

<b>10mA, 1/2I</b>	0.1	4900-5100 (4.9-5.1mA)	Press Test Button	Adjust current, Re-press Test Button Press Lock Button if value in limits
<b>10mA, I</b>	0.1	9900-10100 (9.9-10.1mA)	Press Test Button	Adjust current, Re-press Test Button Press Lock Button if value in limits
<b>30mA, 1/2I</b>	0.1	14900-15100 (14.9-15.1mA)	Press Test Button	Adjust current, Re-press Test Button Press Lock Button if value in limits
<b>30mA, I</b>	0.1	2990-3010 (29.9-30.1mA)	Press Test Button	Adjust current, Re-press Test Button Press Lock Button if value in limits
<b>100mA, 1/2I</b>	0.5	4980-5020 (49.8-50.2mA)	Press Test Button	Adjust current, Re-press Test Button Press Lock Button if value in limits
<b>100mA</b>	1.0	9900-10000 (99-100mA)	Press Test Button	Adjust current, Re-press Test Button Press Lock Button if value in limits
<b>300mA, 1/2I</b>	1.0	14900-15100 (149-151mA)	Press Test Button	Adjust current, Re-press Test Button Press Lock Button if value in limits
<b>500mA, 1/2I</b>	1.0	2490-2510 (249-251mA)	Press Test Button	Adjust current, Re-press Test Button Press lock Button if value in limits
<b>300mA, I</b>	1.0	2990-3010 (299-301mA)	Press Test Button	Adjust current, Re-press Test Button Press Lock Button if value in limits
<b>500mA , I</b>	2.0	4980-5020 (498-502mA)	Press Test Button	Adjust current, Re-press Test Button Press Lock Button if value in limits
<b>1000mA, I</b>	5.0	9950-10050 (995-1005mA)	Press Test Button	Adjust current, Re-press Test Button Press Lock Button if value in limits

## Loop Calibration

**Connect the UUT test lead to the LOOP test box.**  
**Use the Chroma as the power source (230V 50 Hz).**  
Set Battery = 12.0V

### Loop resistance setup

NB The Loop resistance calculation is dependant on the supply voltage remaining constant at 230V – so ensure that the stabilised supply has been appropriately set up.

Before it is possible to calibrate the loop resistance ranges it is necessary to set up the loop balance pot (R182). If this has not been performed at PCB test stage then use the technique detailed below.

Switch the UUT to RCD Ramp range. Setting up the loop balance requires that 230V a.c. is present on the terminals (LE) but it is not crucial exactly what loop resistance is present. Now press the Test Button, the digital display will show an integer value and the analogue pointer displays the same value referenced around the centre point of the arc. Adjust the pot to get the integer value as close to zero as possible (+/- 3 digits is typical). When the pot setup is complete exit the test by pressing the Lock Button. If it is not possible to get the pot within range it may be necessary to replace the 1 microfarad capacitors (C54/C61) with ones that are better matched in value.

### Calibration of the 25A range

Connect the specified loop resistance and press the Test Button, the test should proceed and a result will be displayed. Adjust the value displayed using the Degree Button to increment the value or the Threshold Button to decrease the value.

When the displayed value reaches the target press the Lock Button to store the calibration factor.

If a thermal trip occurs during calibration the message 'Hot' will appear on the display.

**Connect the UUT test lead to the LOOP test box.**

UUT RANGE	APPLY	COMMENTS	TARGET	ACTION
<b>25A</b>	953? (L-PE)	Press Test Button 953?		Adjust Value, Press Lock Button
<b>25A</b>	10?(L-PE)	Press Test Button 10.01?		Adjust Value, Press Lock Button
<b>25A</b>	0?(L-PE)	Press Test Button 0.11?		Adjust Value, Press Lock Button
25A	90?(L-PE)	Press Test Button 89		Adjust Value, Press Lock Button
25A	165? (L-PE)	Press Test Button 163		Adjust Value, Press Lock Button

The tests shown in grey should not be required, but if the value falls outside the limits in final test then the additional range can be calibrated.

Loop resistance setup – Calibration of the NO TRIP range

Switch the UUT to NO TRIP loop range.

Connect the specified loop resistances and press the Test Button, the test should proceed and the overall resistance result will be displayed. To calibrate the instrument, various components of the total resistance value must be calibrated in isolation.

The three components of the measurement are *RL*, *RN* and *RE*. To display the appropriate component press the test button to call it up on the screen. When the *RN* value is displayed, a further press on the test button will cause the display to show the total Live-Earth loop resistance. Pressing the button once more will cause a new test to start.

The *RL* result is indicated by the **Rp** segment being lit. The *RE* value is indicated by the **Rc** segment being lit. The *RN* value is indicated by both **Rc** and **Rp** segments being lit. Adjust the value displayed using the Degree Button to increment the value or the Threshold Button to decrease the value. The degree and threshold buttons have an auto repeat function when held down to allow speedier adjustment.

When the displayed value reaches the target press the Lock Button to store the calibration factor.

If a thermal trip occurs during calibration the message 'Hot' will appear on the display.

UUT RANGE	APPLY	COMMENTS	TARGET	ACTION
<b>NO TRIP</b>	NO TRIP RL & RE 0?	Press Test Button	Rp = 0.11? Rc = 0.00? RpRc = 0.00?	Adjust RL , Press Lock Adjust RE , Press Lock Adjust RN , Press Lock
<b>NO TRIP</b>	NO TRIP RL & RE 10?	Press Test Button	Rc = 9.93?	Adjust RE Press Lock
<b>NO TRIP</b>	NO TRIP 10? RN	Press Test Button	RpRc = 9.91?	Adjust RN , Press Lock
<b>NO TRIP</b>	NO TRIP RL & RE 10?	Press Test Button	Rp = 9.97?	Adjust RL , Press Lock
<b>NO TRIP</b>	NO TRIP RL & RE 0?	Press Test Button	Rp = 0.11? Rc = 0.00?	Check/Adjust RL , Press Lock Check/Adjust RE , Press
Lock			RpRc = 0.00?	Check/Adjust RN , Press
Lock				
NO TRIP	RL=100?,RE=100?	Press Test Button		Adjust Rp, Press Lock Adjust Rc, Press Lock
NO TRIP	RL=1k?,RE=1k?	Press Test Button		Adjust Rp, Press Lock Adjust Rc, Press Lock

The final two tests shown in grey may be omitted as these ranges were automatically calibrated earlier in the 25A range.

## 2. Final Test Specification 6172-816

### Test Equipment

Battery connector  
 Stabilized AC Power Supply (Chroma)  
 AC/DC Voltage Source (Rotek)  
 Multi-function Test Box consisting of...  
*Battery Box*  
*Volts Box*  
*Continuity/Insulation Box*  
*RCD Box*  
*Loop Box*

### Initial Setup

- Assemble the instrument and screw the case together. Do not fit the battery compartment. Carry out calibration procedure 6172-852 before attempting any tests.
- Connect the instrument to the battery simulator and place the instrument on the test jig.
- Battery voltage is 12V unless otherwise stated.  
 Note that the test gear itself consumes almost 20mA from the UUT so 20mA has been added to all the supply current data (except for the 'OFF' current).  
 Also a typical volt drop of 0.2V occurs along the battery lead, during the battery voltage reading test. This has been allowed for.  
 Any references to the **Backlight** should be ignored on the MFT1501.
- To put the UUT into **Test mode**, use the PC control programme, or else the front panel controls, as follows:  
 Select the **5I 1000mA** rcd test while pressing the yellow test button and the orange threshold button.  
 The instrument displays 'CUS' (customer mode).  
 Press any button twice to select 'TES'. (First press selects 'CAL').  
 When the rotary switch is turned, the instrument briefly displays 'SET' to confirm that the new mode has been set.  
 If the display shows 'unc' at switch-on, then the instrument is uncalibrated and should be put through the full calibration sequence.

### Initial Tests

#### Switch to UUT to 'OFF'

Set Battery = 10.0V

UUT RANGE	APPLY	ACTION	READ
<b>Select 'uA' on the Battery Box</b>			
1. <b>OFF</b>			35 – 75(uA) <b>On Battery Box</b>
Select 'mA' on the Battery Box			
2. <b>OFF</b>		Press Test and Lock buttons together	9.6V – 10.0V
(0.2V is dropped along the battery lead)			

Set Battery = 12.0V

Switch on UUT and put it into Test Mode

On the MFT1502, check that the backlight and label illuminate correctly.

On the MFT1501, check that there is no backlight or label illumination.

Set the UUT to the **V** range and check that the buttons function correctly.

They should respond with a low-pitched beep, except the Backlight button, which produces a high-pitched beep.



## Voltage Tests

Connect the UUT test lead to the Voltage test box.  
Use the Rotek as the voltage source.

Set Battery = 12.0V

UUT RANGE	APPLY	ACTION	READ
Set the Volts Box to OFF			
1. V		UUT Backlight OFF	0 - 2V Battery symbol is OFF 50-95(mA) <b>On Battery Box</b> (20mA is used by the test box)
		UUT Backlight ON	170-220(mA) <b>On Battery Box</b> (20mA is used by the test box))
Set the Volts Box to L-E			
2. V	5.0Vdc		4V - 6V
3. V	5.0V(ac 50Hz)		4V - 6V
4. V	230V(ac 50Hz)		227V - 233V ~
5. V	-230Vdc		-225V - -235V
6. <b>250V MW</b>	230V (ac 50Hz)		227V - 233V ~ (flashing)
7. V	480V(ac 50Hz)		473V - 487V ~

Set the Rotek to Standby.

## Ohms Tests

Connect the UUT test lead to the Ohms/Insulation test box.

Set Battery = 12.0V

UUT RANGE	APPLY	ACTION	READ
1. W	0Ω	Press Test button to Zero reading	-0.00Ω - 0.01Ω
2. W	2Ω		200 – 250(mA) <b>On Ohms Box</b>
3. W	50Ω		49.0Ω - 51.0Ω
4. W	50kΩ		49.0kΩ - 51.0kΩ
5. W	O/C (1MΩ)		3.6 – 4.0(V) <b>On Ohms Box</b> >99.9kΩ (after a few seconds) Battery symbol is OFF
Set <b>Battery = 17.3V, then 7.3V</b> Note: Battery volts must be selected before applying 0Ω			
6. W	0Ω		-0.00Ω - 0.01Ω
Battery symbol is ON			

## Buzzer Tests

Set Battery = 17.3V, then 12.0V

UUT RANGE	APPLY	ACTION	READ
1. <b>Buzzer (2W)</b>	150k $\Omega$		--- 'Contact' symbol shows Battery symbol is OFF
2. <b>Buzzer</b>	500k $\Omega$		--- 'No Contact' symbol shows
3. <b>Buzzer</b>	3 $\Omega$		--- Buzzer is OFF
4. <b>Buzzer</b>	1 $\Omega$		<2 $\Omega$ Buzzer is ON

## Insulation Tests

Set Battery = 12.0V

UUT RANGE	APPLY	ACTION	READ
1. <b>250V MW</b>	250k $\Omega$	Press Test Button	0.23M $\Omega$ - 0.27M $\Omega$ 253 – 275(V) <b>On Ohms Box</b>
(Note that the warning triangle flashes during Insulation tests to show that a test is in progress)			
2. <b>250V MW</b>	50M $\Omega$	(Press Test Button)	49.0M $\Omega$ - 51.0M $\Omega$
1. <b>500V MW</b>	100k $\Omega$	(Press Test Button)	< 1950( $\mu$ A) <b>On Ohms Box</b>
2. <b>500V MW</b>	400k $\Omega$	(Press Test Button)	0.38k $\Omega$ - 0.42k $\Omega$ 405 – 450(V) <b>On Ohms Box</b>
3. <b>500V MW</b>	500k $\Omega$	(Press Test Button)	0.48k $\Omega$ - 0.52k $\Omega$ 505 – 550(V) <b>On Ohms Box</b>
4. <b>500V MW</b>	50M $\Omega$	(Press Test Button) (Backlight OFF)	49.0M $\Omega$ – 51.0M $\Omega$ <220(mA) <b>On Battery Box</b> (20mA is used by the test box)
5. <b>500V MW</b>	0 M $\Omega$	Press Test Button	0.00M $\Omega$ Battery symbol is OFF
Set Battery = 17.3V, then 7.3V			
6. <b>500V MW</b>	0M $\Omega$	Press Test Button	0.00 M $\Omega$ Battery symbol is ON
Set Battery = 7.9V, then 5.9V			
7. <b>500V MW</b>		Battery symbol flashes for a few seconds.	Instrument switches OFF

Set Battery = 17.9V, then 12.0V  
Put UUT into Test Mode

1. <b>1000V MW</b>	1M $\Omega$	Press Test Button	0.97M $\Omega$ - 1.03M $\Omega$ 1010 – 1100(V) <b>On Ohms Box</b>
2. <b>1000V MW</b>	50M $\Omega$	(Press Test Button)	49.0M $\Omega$ - 51.0M $\Omega$
3. <b>1000V MW</b>	450M $\Omega$	(Press Test Button)	435M $\Omega$ - 460M $\Omega$ (Takes several seconds to settle)

## Insulation Tests with SPL1000 Probe

**Remove the mains lead from the UUT and connect the SPL1000 Probe.**

Turn the range switch on the UUT to 500V MΩ and then back to 1000V MΩ

Set Battery = 12.0V

UUT RANGE	APPLY	ACTION	READ
1. <b>1000V MW</b>	----		Check that the <b>SPL1000</b> RED/GREEN led is <b>OFF</b>
2. <b>1000V MW</b>	O/C	Press <b>SPL1000</b> Test Button	Check that <b>SPL1000</b> led flashes <b>RED</b> (1000V range warning)
		Wait for reading	>499MΩ
3. <b>1000V MW</b>	0MΩ	Wait for reading	Check that <b>SPL1000</b> led goes <b>GREEN</b>
		Press <b>SPL1000</b> Test Button	0.00MΩ
			Check that the test stops. (Triangle symbol stops flashing)

Ensure that the Insulation test has stopped (triangle symbol OFF), before proceeding with the next section.

## RCD Tests

**Connect the UUT test lead to the RCD test box.**

**Use the Chroma as the power source. Set to 230V 50Hz.**

Set Battery = 12.0V.

UUT RANGE	APPLY	ACTION	READ
1. <b>1/2I, 10mA</b>	10mA	Press Test button	4600 – 4900 <b>On RCD Box</b> (4.6 – 4.9mA)
2. <b>I, 10mA</b>	10mA	Press Test button	10200 – 10800 <b>On RCD Box</b> (10.2 – 10.8mA)
3. <b>I, 30mA</b>	100mA	Press Test button	3050 – 3250 <b>On RCD Box</b> (30.5 – 32.5mA)
4. <b>I, 300mA</b>	1A	Press Test button	3050 – 3250 <b>On RCD Box</b> (305 – 325mA)
5. <b>I, 500mA</b>	1A	Press Test button	5050 – 5400 <b>On RCD Box</b> (505 – 540mA)
6. <b>I, 1000mA</b>	1A	Press Test button	10100 – 10800 <b>On RCD Box</b> (1.01 – 1.08A)
7. <b>I, 10mA</b>	825ms	Press Test button	815ms - 829ms
8. <b>I, 30mA</b>	30ms	Press Test button	27.0ms – 29.0ms
			0° symbol is ON
		Press Degree button (blue) to select 180° test	
9. <b>I, 30mA</b>	30ms	Press Test button	27.0ms – 29.0ms
			180° symbol is ON
			Battery symbol is OFF
		Set <b>Battery = 17.3V, then 7.3V</b>	
10. <b>I, 30mA</b>	100mA	Press Test button	3050 – 3250 <b>On RCD Box</b> (3.05 – 3.25mA)
			Battery Symbol is ON

## Loop Tests

Connect the UUT test lead to the LOOP test box.

Use the Chroma as the power source. Set to 230V 50Hz.

Set Battery = 12.0V

When testing, always use the settings on the LOOP test box marked '25A L-E'.

UUT RANGE	APPLY	ACTION	READ
1. 25A Loop	2.2k $\Omega$ (2.2045k)	Press Test button	2.11k $\Omega$ -2.29k $\Omega$
2. 25A Loop	953 $\Omega$ (953.44)	Press Test button	905 $\Omega$ - 1.00k $\Omega$
3. 25A Loop	165 $\Omega$ (162.732)	Press Test button	153 $\Omega$ - 173 $\Omega$
4. 25A Loop	90 $\Omega$ (89.173)	Press Test button	86.0 $\Omega$ - 92.4 $\Omega$
5. 25A Loop	20 $\Omega$ (20.339)	Press Test button	19.2 $\Omega$ - 21.5 $\Omega$
6. 25A Loop	10 $\Omega$ (10.0075)	Press Test button	9.68 $\Omega$ - 10.34 $\Omega$
7. 25A Loop	1 $\Omega$ (1.109)	Press Test button	1.05 $\Omega$ - 1.17 $\Omega$
8. 25A Loop	0 $\Omega$ (0.11)	Press Test button	0.08 $\Omega$ - 0.14 $\Omega$

Battery symbol is OFF

Set Battery = 17.3V, then 7.3V

9. 25A Loop	0 $\Omega$ (0.11)	Press Test button	0.08 $\Omega$ - 0.14 $\Omega$
-------------	-------------------	-------------------	-------------------------------

Battery symbol is ON

Set Battery = 17.3V, then 12.0V

1. PSC Loop	0 $\Omega$ (0.11)	Press Test button	1.6kA – 2.9kA
-------------	-------------------	-------------------	---------------

1. No Trip Loop	0 $\Omega$ (0.11)	Press Test button	0.08 $\Omega$ - 0.14 $\Omega$
2. No Trip Loop	1 $\Omega$ (1.109)	Press Test button	1.05 $\Omega$ - 1.17 $\Omega$
3. No Trip Loop	10 $\Omega$ (10.0075)	Press Test button	9.68 $\Omega$ - 10.34 $\Omega$

## 3-Phase Loop Test

Disconnect the plug terminated test lead from the UUT.

Connect the UUT to the LOOP test box 3-phase connectors using a 2-wire lead set. Connect the Red phase to the UUT L1 (Red) connector on the UUT and the Yellow phase to the UUT L2 (Green) connector.

UUT RANGE	APPLY	ACTION	READ
Set the Loop box to 10(P2).			
1. 25A (3phase)	10 $\Omega$ (9.9275)	Press Test button	9.8 $\Omega$ - 10.6 $\Omega$

When the full set of tests is completed the Instrument can be removed and the label affixed over the programming aperture in the battery compartment.

## **Appendix 6 Instrument Final Specifications**

### **Electrical specification**

#### **Voltage range**

The voltage will enable the user to ascertain if a system is live prior to testing.

Accuracy  $\pm 2\%$   $\pm 2$  digits

Voltage ac - 000V - 500V 50/60Hz

Voltage dc - 000V - 500V (Indication of polarity above 10V)

#### **Insulation ranges (to EN 61557-2)**

Accuracy  $\pm 2\%$   $\pm 2$  digits up to 99 M $\Omega$

Short circuit current <2mA

1mA at min. pass value of insulation specified in BS7671, HD384 and IEC364

250V 0.01 - 99.9M $\Omega$

500V 0.01 - 299M $\Omega$

1000V 0.01 - 499M $\Omega$

250,500 and 1kV into 1mA load

Output voltage +20% - 0% at rated load or less.

Auto discharge facility safely discharges connected circuit after test.

Live circuit warning/Inhibit when connected to Live circuits (Threshold 55V)

#### **Loop ranges (to EN 61557-3)**

##### **Line/Earth (Single phase)**

Supply 55V - 280V 45Hz to 65Hz

25A 0.01 $\Omega$  - 9.99  $\Omega$  ( $\pm 5\%$   $\pm 0.03\Omega$ )

10.0 $\Omega$  - 89.9 $\Omega$  ( $\pm 5\%$   $\pm 0.5\Omega$ )

90 $\Omega$  - 899 $\Omega$  ( $\pm 5\%$   $\pm 5\Omega$ )

900 $\Omega$  - 3.00k $\Omega$  ( $\pm 5\%$   $\pm 20\Omega$ )

##### **Line/Line(Three phase)**

Supply 55V - 480V 45Hz to 65Hz

25A 0.01 $\Omega$  - 9.99 $\Omega$  ( $\pm 5\%$   $\pm 0.03\Omega$ )

##### **Low current Loop (No Trip)**

Supply 55V - 280V 45Hz to 65Hz

15mA 0.01 $\Omega$  - 2.00k $\Omega$  ( $\pm 5\%$   $\pm 0.03$  ohms  $\pm$  Noise Margin ).

##### **Prospective Short-circuit Current (PSC)**

Prospective Short circuit current = Nominal Voltage / Loop Resistance

Accuracy is therefore derived from the loop test.

1A - 199A 1A resolution

0.02kA - 1.99kA 10A resolution

2.0kA - 19.9kA 100A resolution

#### **Continuity (to EN 61557-4)**

Ohms 0.01 $\Omega$  - 99.9 $\Omega$  ( $\pm 2\%$   $\pm 2$  digits)

100 $\Omega$  - 99.9k $\Omega$  ( $\pm 5\%$   $\pm 2$  digits)

Buzzer Operates continuously at less than selected limit .

Selectable limits of 2 $\Omega$  ,5 $\Omega$  ,10 $\Omega$  ,20 $\Omega$  ,50 $\Omega$  , 100 $\Omega$

Open circuit voltage 4-5Vdc

Test current >200mA at 2 $\Omega$

Test Lead resistance zeroing : Up to 9.99 $\Omega$  (zero uses Test Button)

### **RCD ranges(to EN-61557-6)**

Supply 100V - 270V 45Hz to 65Hz

Ranges- 1000mA, 500mA, 300mA, 100mA, 30mA, 10mA

Type - 1/2I - 1/2 times the selected current.

I - One times selected current.

5I - Five times I current.

I trip - A ramp test that displays actual trip current .

DC sensitive. - A DC test current at I current.

Current accuracy  $\pm 3\%$

Trip time accuracy  $\pm 1\% \pm 1\text{ms}$

### **Remote Probe MFT1502 only (Optional on MFT1501)**

Torch feature 5mm White LED

1500mcd

Safety CLASS 1 LED to IEC 60825:2001

Interchangeable tips:

Standard

Pareable

Long

Battery 9V PP3

Red/Green LED RED indicates that the instrument is displaying a warning (eg volts on an insulation range)

GREEN indicates that the display on the instrument is valid or if the Continuity Buzzer on the instrument is sounding.

### **Power Supply**

Instrument:- 8 x 1.5V Alkaline cells type LR6 (AA cells)

Illuminated switched Probe:- 1 x 9V Alkaline cell type PP3

### **Fuses**

Instrument:-

Replaceable 500mA (F) HBC 10kA 500V

Non-replaceable 7A(SIBA 70-065-63) X2

Non-replaceable 1A

Probe:-

Non-replaceable 7A(SIBA 70-065-63)

### **Safety**

Double insulated to IEC1010-1:2001 , Installation Category III , 300V phase to earth , 500V phase to phase.

In addition Probe designed to meet IEC 1010-031:2002 , Double insulated to Installation Category III , 300V phase to earth, 500V phase to phase.

## **EMC**

In accordance with IEC61326 including amendment No. 1

## **Environmental**

Operating range: -5 to +40

Operating Humidity: 90% RH at 40 max

Storage temperature: -25 to 65

Maximum altitude: 2000m

Dust and water protection: Instrument IP54 , Probe no rating

## **IEC61557**

Complies with the following parts of 61557,Electrical safety in low voltage systems up to 1000V ac and 1500V dc-  
Equipment for testing , measuring or monitoring of protective measures:-

Part1-General Requirements

Part2-Insulation resistance

Part3-Loop resistance

Part4-Continuity

Part5- Earth test

Part6-Residual Current Devices(RCD)

Part10-Combined Measuring Equipment

## **Appendix 7 List of Errors – MFT series**

<b><u>Error number</u></b>	<b><u>Description</u></b>
1	Number to be displayed is >1999
2	Invalid decimal point
3	Invalid arc pointer number
4	Event buffer overflow
5	Invalid Lcd drive parameter
6	Ad status (7109) stuck high
7	Ad status (7109) stuck low
8	Watchdog not running
9	UAD parameter invalid (signal)
10	Internal UAD error
11	UAD reading parameter error
12	Invalid latch number
13	System hangup
14	Invalid rotary switch parameter
15	Unstable data from push buttons
16	Battery measurement fault – very low reading
17	Probe circuit fault (red) – sense line too high (>2.75V)
18	Probe circuit fault (green) – sense line too low (<2.25V)
19	Probe circuit fault (off) – sense line too low (<2.25V)
20	Probe circuit fault (sense) – sense line ool (>3.75V, <1.25V)
21	Wrong ucontroller mode (not mode 7)
22	Unstable reading from main rotary switch
23	Unstable reading from current switch
24	Invalid reading from main rotary switch
25	Invalid reading from current switch
26	External AD (7109) error – conversion unfinished
27	-5V rail not switched on
28	18V rails not switched on
29	Attempt to enable/disable relays in energized condition
30	Self-check reading from ad converter (7109) out of limits
31	Rs232 error
32	No acknowledge from eeprom
33	Voltage measurement error – attribute unknown
34	Frequency measurement error
35	Invalid kilohms or megohms range set/requested
36	Invalid parameter for terminal voltage measurement
37	Fault in power-down circuit
38	Negative ad result resulting from ac-dc converter output
39	Invalid hv inverter voltage setting
40	Invalid hardware configuration on ohms/kilohms
41	Display fault
42	Negative overrange on ohms/kilohms
43	Zero reference with in-range result on ohms/kilohms
44	Invalid buzzer threshold setting
45	Invalid main switch setting in megohms test
46	Do not use this routine
47	Excessive time spent in insulation test discharge
48	Invalid display ‘S’ number
49	Invalid interrupt
50	Pld error – ce- not pulled up



<u>Error number</u>	<u>Description</u>
51	Latch enable error - no pullup
52	Rcd error - gain/current ctrl not pulled up
53	Eeprom error - SCL or SDA not pulled up
54	Backlight error - ctrl not pulled down
55	Buzzer error - ctrl not pulled down
56	UAD mux - ctrls not pulled up
57	Power supply error – +/-18V or –5V ctrls not pulled down
58	Eeprom SDA port set error – P4DR bit 0 is set high
59	Probe error – cannot check probe condition if probe not energized
60	Display routine cannot recognise test type selected
61	Out of range fet temperature reading
62	Nested display controller writes
63	Oki controller error – signals not pulling down
64	Oki controller error - signals not driving high
65	Oki controller error - signals shorted
66	Data bus – lines not pulling up
67	Data bus – lines not driving low
68	Data bus – lines shorted
69	Battery measurement fault – high reading
70	2.5V reference out of limits
71	-5V supply out of limits
72	+18V supply too large (>20V)
73	+18V supply too small (<16V)
74	-18V supply magnitude too large (>20V)
75	-18V supply magnitude too small (<16V)
76	RCD/Loop error code outside of permitted range
77	Loop measurement – unloaded ad reading is bigger than loaded
78	RCD current calibration has run out of adjustment
79	Invalid parameter in result display routine
80	Digipot has hit endstop (255)
81	Invalid PLD mode or load specified
82	Ohms/Kohms amplifier offset out of limits (>10mV)
83	Not used
84	Not used
85	Not used
86	Not used
87	Not used
88	Not used
89	Not used
90	Not used
91	Not used
92	Visual State error - SES_ACTIVE
93	Visual State error - SES_CONTRADICTION
94	Visual State error - SES_RANGE_ERR
95	Visual State error - SES_TEXT_TOO_LONG
96	Visual State error - SES_TYPE_ERR
97	Visual State error - SES_EMPTY
98	Visual State error - SES_BUFFER_OVERFLOW
99	Visual State error - SES_SIGNAL_QUEUE_FULL

## **Appendix 8 Production Software / Known problems**

### **Version 1.6**

Minor bug fix when relay pcb not connected  
Allow display of negative loop resistance in cal/final test

### **Version 1.5**

S-type breaker test introduced for Stoke City Council and now to be a standard feature.  
A small bug fix on the voltmeter mods to stop the larger noise level from causing the backlight to keep turning on  
loop 3 wire component parts display change

### **Version 1.4**

Voltmeter mods for Euro Index etc.

### **Version 1.3**

Test Gear rcd current hold feature  
Checks on +18V and -18V supplies  
ERROR4 on volts fix (larger event buffer + extra event buffer clear etc.)  
Error 82 replaces error44 as ohms amplifier offset error, since error 44 was inadvertently used for 2 different errors  
Bug fix whereby spurious digits appearing on display when going from Volts to Off  
Calibrate failed warning added to ohms/megohms/volt.  
Bug fix - on ohms/buzzer, following exit from test due to low battery, the battery voltage was not being measured any more.  
Method of getting into Diagnostics via push buttons and rotary switches  
Method of getting into Diagnostics or Test mode or Cal mode via shorting links on comms interface  
Calibrate failed warning added to loop/rcd  
Decalibrate added to loop/rcd  
Capability for testing ordinary breakers up to 400ms (300ms wanted but 400ms will do)

### **Version 1.2**

Error 69 sometimes occurred during test procedure due to battery voltage being too high – Error 69 now disabled in final test mode  
Error 4 sometimes occurred during voltage calibration – bug fixed, event buffer size increased  
3 phase test maximum start voltage raised to 460V, was 440V

### **Version 1.1**

This version was issued to be used with the A5 and upwards display PCB . It returns the LED's for ramp and DC RCD tests to their correct position.

### **Version 1.0**

DISPLAY PCB'S UP TO AND INCLUDING ISSUE A4 HAD VARIOUS ERRORS WITH THE LED'S FOR DC AND RAMP FUNCTIONS BEING SWAPPED. THERE WAS A TEMPORARY CORRECTION IN THE SOFTWARE ON EARLIER VERSIONS. THIS CORRECTION IS REMOVED IN V1.1 MEANING THAT ALL IS NOW CORRECT

## **Appendix 9 Diagnostic Mode**

### **1.General Description**

There are 5 ways to access diagnostics...

1. The diagnostics diode can be fitted, in which case a special test sequence begins after the start-up messages. The display will confirm diagnostics mode with the message 'dia', and then start the first test automatically.
2. Select any of the 3 switch positions anticlockwise from Insulation. (This is normally prevented by the switch stop). The display will confirm diagnostics mode with the message 'dia', but will not begin test sequence until a key is pressed.
3. Select an illegal RCD switch position while simultaneously pressing all the pushbuttons (backlight button press is optional as it is not fitted on the MFT1501). Then press a key to enter diagnostics, or turn the rotary switch to abort.
4. By a link on the test gear interface. Fit a shorting link between pins 3 & 5 (DIAGS & FLASH\_OUT). These are the pins which are 2<sup>nd</sup> & 3<sup>rd</sup> from the left in the bottom row, as viewed through the battery compartment.
5. Select a diagnostics switch position by use of the serial communications port (as Method 2).

During the test sequence, the normal action of the rotary switches is disabled, and the push buttons have different functions to usual.

When the diagnostic test sequence is completed, normal instrument operation returns.

To escape from the diagnostic test sequence, press all buttons in the group of 3 simultaneously. This forces a reset

If the instrument detects that the relay board is not connected, certain tests will be automatically skipped.

### **2.Diagnostic Tests**

#### **Test 1 - display, and power supplies**

High-pitched beep.

Message - 'diS'

All display segments are turned on.

Backlight is turned on.

-5V supply is turned on.

18V supplies are turned on.

HV inverter is turned on and set for 25V.

Probe led is set Green.

Press the 'test' button to toggle the buzzer on/off.

(The buzzer tone is a highish frequency, about 7kHz).

The probe led is set for 'red' when the buzzer is 'on' and 'green' when the buzzer is 'off'.

On exiting the led is turned 'off'.

Press any other button to move on to next test.

#### **Test 2 - data bus**

High-pitched beep.

Message - 'db'

Sets data bus to be inputs and displays the levels as a hex byte.

Right-hand digit = Low 4 bits

Press any button to move on to next test.

### **Test 3 - push buttons**

High-pitched beep.

Message - 'PbS'

No buttons pressed - display shows '---'

Press 'test' button - display shows 'tES'

Press 'threshold' button - display shows 'thr'

Press 'degree' button - display shows 'dEg'

Press 'backlight' button - display shows 'bAc'

Press 'lock' button - display shows 'LOC'

(Remote key commands have no effect)

Press 2 buttons together to move on to next test, or send 'escape' character.

### **Test 4 - Power Supplies**

Test 4.1 - 2.5V reference

High-pitched beep.

Message - '2.5V'

Displays the 2.5V ref, as measured by the uad

Press any button to move on to next test.

Test 4.2 - battery

High-pitched beep.

Message - 'bAt'

Displays battery voltage and battery symbol.

Press any button to move on to next test.

Test 4.3 - -5V supply

High-pitched beep.

Message - '- 5V'

Displays -5V supply, as measured by the uad.

Press any button to move on to next test.

Test 4.4 - 18V supply

High-pitched beep.

Message - '18V'

Displays -18V supply, as measured by the uad.

Press any button to move on to next test.

Test 4.4 - -18V supply

High-pitched beep.

Message - '18V'

Displays 18V supply, as measured by the uad.

Press any button to move on to next test.

## **Test 5 - Switches**

Test 5.1 - rotary main switch

High-pitched beep.

Message - 'rot' followed by 'LLL'

Displays the tapping numbers relating to the main switch position.

Appears on display as " tapping a, 'L', tapping b "

('L' = left-hand switch).

Also turns on relevant led.

Press any button to move on to next test.

Test 5.2 - rotary current switch

High-pitched beep.

Message - 'rot' followed by 'rrr'

Displays the tapping numbers relating to the main switch position.

Appears on display as " tapping a, 'r', tapping b "

('r' = right-hand switch).

Also turns on relevant led.

Press any button to move on to next test.

## **Test 6 - 7109 ad converter**

High-pitched beep.

Message - ' Ad '

The reference is set to 1V.

The ad converter is set to run continuously, measuring its own reference.

Display toggles the 'breaker fixed contact' symbol with each conversion, and shows the ad reading divided by 4.

Thus the breaker symbol should flash slowly and the reading should be '512'

(1 or 2 digits low is normal).

Press any button to move on to next test.

## **Test 7 - uprocessor ad converter**

High-pitched beep.

Message - ' UAd', followed by e.g. ' C0 ' (channel number)

Displays the unprocessed reading for the currently selected channel.

If the relay board is not connected, and the selected uad channel uses the relay board, then the overrange and underrange symbols are also shown, together with the warning triangle.

Channel numbers are shown as ' C0 ' through to ' C5 ' for the main uad channels 0 - 5.

Then ' C60' through to ' C67' for the 8 subchannels on uad channel 6.

Then ' C70' through to ' C77' for the 8 subchannels on uad channel 7.

The first digit always indicates the uad channel, and the second digit shows the sub-channel.

Press the 'lock' button, 'backlight' button or 'test' button to step through the sequence and eventually move on to the next test.

Press 'degree' or 'threshold' button to escape directly to the next test type.

### **Test 8 - relays**

This test is skipped if the relay board is not connected.

High-pitched beep.

Message - ' rLY', followed by e.g. ' L ' (relay identifier)

One relay only is energized.

Display shows 'breaker closed' symbol to indicate that the named relay is closed.

Step through sequence below with the 'lock' button.

- 1 - Live relay (display shows ' L ')
- 2 - Neutral/Earth select relay (display shows ' nE ')
- 3 - Hi relay (display shows ' HI ')
- 4 - Lo relay (display shows ' LO ')
- 5 - Relays disabled (display shows ' oFF', and 'breaker open' symbol)  
(Relays drive are set to energize relays,  
but master relay enable is set low).

Press the 'lock' button, 'backlight' button or 'test' button to step through the sequence and eventually move on to the next test.

Press 'degree' or 'threshold' button to escape directly to the next test type.

### **Test 9 - High voltage inverter**

Test 9.1 - high voltage inverter 25V setting

High-pitched beep.

Message - ' inv', followed by ' 25V'

The 'L' relay is closed and the display shows the output voltage as measured by the uad. If the relay board is not connected, then the display shows ??? as the voltage.

The display also shows the warning triangle symbol.

Press the 'test' button to show the current in the 1k reference resistor.

Press the 'lock' button, or 'backlight' button to move on to the next test.

Press 'degree' or 'threshold' button to escape directly to the test type.

Test 9.2 - high voltage inverter 250V setting

High-pitched beep.

Message - ' inv', followed by ' 250V'

The 'L' relay is closed and the display shows the output voltage as measured by the uad. If the relay board is not connected, then the display shows ??? as the voltage.

The display also shows the warning triangle symbol.

Press the 'test' button to show the current in the 1k reference resistor.

Press the 'lock' button, or 'backlight' button to move on to the next test.

Press 'degree' or 'threshold' button to escape directly to the test type.

Test 9.3 - high voltage inverter 500V setting

High-pitched beep.

Message - ' inv', followed by ' 500V'

The 'L' relay is closed and the display shows the output voltage as measured by the uad. If the relay board is not connected, then the display shows ??? as the voltage.

The display also shows the warning triangle symbol.

Press the 'test' button to show the current in the 1k reference resistor.

Press the 'lock' button, or 'backlight' button to move on to the next test.

Press 'degree' or 'threshold' button to escape directly to the test type.

Test 9.4 - high voltage inverter 1000V setting  
High-pitched beep.  
Message - ' inv', followed by '1000V'

The 'L' relay is closed and the display shows the output voltage as measured by the uad. If the relay board is not connected, then the display shows ??? as the voltage. Note that the uad can only read reliably up to 750V, so the normal reading on this test is '>750V'.

The display also shows the warning triangle symbol.  
Press the 'test' button to show the current in the 1k reference resistor.  
Press the 'lock' button, or 'backlight' button to move on to the next test.  
Press 'degree' or 'threshold' button to escape directly to the test type.

Test 9.5 - high voltage inverter OFF setting  
High-pitched beep.  
Message - ' inv', followed by ' oFF'

The output is set for 500V, but is disabled.  
The 'L' relay is closed and the display shows the output voltage as measured by the uad. If the relay board is not connected, then the display shows ??? as the voltage. Reading should be less than about 10V.

Display also shows the warning triangle symbol.  
Press the 'test' button to show the current in the 1k reference resistor.  
Press the 'lock' button, or 'backlight' button to move on to the next test.  
Press 'degree' or 'threshold' button to escape directly to the test type.

### **Test 10 – contact detect circuit**

This test is skipped if the relay board is not connected.  
High-pitched beep.  
Message - ' cct'

Sets conditions to detect ohms contact and displays the contact detect uad reading. Display shows 'closed' or 'open' breaker symbol as appropriate  
Press any button to move on to the next test.

### **Test 11 - Kilohms ranges**

Test 11.1 - kilohms low range  
High-pitched beep.  
Message - ' rng', followed by ' LO k'

Sets conditions for kohms test current to flow.  
Sets the reference resistor to be 1k.  
Measures and displays voltage on lo\_v, as measured by the uad.

Press the 'test' button to show the current in the 1k reference resistor.  
Press the 'lock' button, or 'backlight' button to move on to the next test.  
Press 'degree' or 'threshold' button to escape directly to the test type.

Test 11.2 - kilohms middle range  
High-pitched beep.  
Message - ' rng', followed by 'mid k'

Sets conditions for kohms test current to flow.  
Sets the reference resistor to be 10k.  
Measures and displays voltage on lo\_v, as measured by the uad.

Press the 'test' button to show the current in the 10k reference resistor.  
Press the 'lock' button, or 'backlight' button to move on to the next test.  
Press 'degree' or 'threshold' button to escape directly to the test type.  
Next press of 'lock' button moves on to next test.

Test 11.3 - kilohms high range  
High-pitched beep.  
Message - 'rng', followed by 'HI k'

Sets conditions for kohms test current to flow.  
Sets the reference resistor to be 100k.  
Measures and displays voltage on lo\_v, as measured by the uad.

Press the 'test' button to show the current in the 100k reference resistor.  
Press the 'lock' button, or 'backlight' button to move on to the next test.  
Press 'degree' or 'threshold' button to escape directly to the test type.

**Test 11.4 - kilohms top range**  
High-pitched beep.  
Message - 'rng', followed by 'toP k'

Sets conditions for kohms test current to flow.  
Sets the reference resistor to be 1M.  
Measures and displays voltage on lo\_v, as measured by the uad.

Press the 'test' button to show the current in the 1M reference resistor.  
Press the 'lock' button, or 'backlight' button to move on to the next test.  
Press 'degree' or 'threshold' button to escape directly to the test type.

**Test 12 - ohms ranging**  
High-pitched beep.  
Message - 'rng'

Sets conditions for ohms test current to flow.  
Measures and displays voltage on lo\_v, as measured by the uad.

Press the 'test' button to show the current in the 5R reference resistor.  
Press any other button to move on to the next test.

**Test 13 - Serial link (comms)**  
Test 13.1 - serial link 0 (comms)  
High-pitched beep.  
Message - 'SEr', followed by 'r 0', followed by 't 0'.

Tests serial link 0, the comms channel.  
Uses RX0 and TX0.

Alphanumeric characters received at TX0 are echoed back via RX0.  
The received character is also shown on the MFT1501 display, if possible.  
(Certain characters are not compatible with 7-segment format).

Press any button to move on to the next test, or send 'escape' character.

**Test 13.2 - serial link 1 (flash)**  
High-pitched beep.  
Message - 'SEr', followed by 'r F', followed by 't F'.

Tests serial link 1, the flash programmer channel.  
Uses FLASH\_IN and FLASH\_OUT.

Alphanumeric characters received at FLASH\_IN are echoed back via FLASH\_OUT.  
The received character is also shown on the MFT1501 display, if possible.  
(Certain characters are not compatible with 7-segment format).

Press any button to move on to the next test, or send 'escape' character.

**Test 13.3 - serial link 0/1 crosscheck**  
High-pitched beep.  
Message - 'SEr', followed by 'r 0', followed by 't F'.



Does a cross check using both serial links.

If the flash channel does not work then tests 13.3 and 13.4 can determine whether the transmit or receive is at fault.

Uses RX0 and FLASH\_OUT.

Alphanumeric characters received at RX0 are echoed back via FLASH\_OUT.

The received character is also shown on the MFT1501 display, if possible.

(Certain characters are not compatible with 7-segment format).

Press any button to move on to the next test, or send 'escape' character.

#### Test 13.4 - serial link I/O crosscheck

High-pitched beep.

Message - 'SEr', followed by ' r F', followed by ' t 0'.

Does a cross check using both serial links.

If the flash channel does not work then tests 13.3 and 13.4 can determine whether the transmit or receive is at fault.

Uses FLASH\_IN and TX0.

Alphanumeric characters received at FLASH\_IN are echoed back via TX0.

The received character is also shown on the MFT1501 display, if possible.

(Certain characters are not compatible with 7-segment format).

Press any button to move on to the next test, or send 'escape' character.

#### Test 14 - probe

This test is skipped if the relay board is not connected.

High-pitched beep.

Message - ' Prb', followed by e.g. ' UAd'

Step through sequence using 'lock' button

14.1 - uad reading (volts check)

Display shows probe reading, (unprocessed data) with the identifier 'Rp' (probe reading). Nominal reading is 511/512

14.2 - led is red, display shows ' rEd'

14.3 - led is green, display shows ' grE'

14.4 - led is off, display shows ' oFF'

In 2,3 and 4...

Shows led symbol on display (neon blob) to show that probe led is being controlled.

If probe is connected...

Display shows breaker fixed contact symbol.

Display shows closed contact symbol if probe switch is pressed.

Displays shows open contact symbol if probe switch is not pressed.

If an error is detected at any time (out of range reading), the warning triangle is displayed.

Press the 'lock' button, 'test' button, or 'backlight' button to move on to the next test.

Press 'degree' or 'threshold' button to escape directly to the test type.

#### Test 15 - eeprom

High-pitched beep.

Message - ' EEP'

Transmits entire memory contents through serial link.

Checks eeprom by writing AA & 55 to every address and reading back.

If an error is detected, checks pullup on eeprom\_sda line.

The original contents of the memory is preserved.

Press any button to move on to the next test.

## **Test 16 RCD**

Warning: Do not connect more than 270V ac to the terminals during these tests – in diagnostics mode the software protection has been bypassed and as the circuits are not rated for more than this voltage damage will occur.

Test 16.1 – Frequency

High pitched beep

Message - 'FrE'

Displays the frequency of the ac mains applied – if no ac volts are present, then displays 0.00 and the ac symbol (~). If frequency is incorrect or missing, check around IC9.

Press any button to move on to the next test.

Test 16.2 – FET heatsink temperature

High pitched beep

Message - ' °C'

Displays the temperature of the heatsink in degrees centigrade. If the instrument has been doing RCD or loop tests, this might be quite high. Otherwise it should be around ambient temperature. The sensor is located on the opposite side of the board to the heatsink. The thermometer symbol is switched on the display.

Press any button to move on to the next test.

Test 16.3 – RCD current path (15mA)

High pitched beep

Message - '15 mA'

Attempts to run 15mA RCD current continuously (Live Earth) – a bit like a very long no trip test.

**Caution: the current waveform may be missing some little slices as the PLD LOAD CONTROL monostables (IC31) time out due to the amount of time spent measuring the FET temperature.**

Displays the temperature of the heatsink in degrees centigrade during this test, the contact symbol is shown closed and the thermometer symbol is switched on.

The test assumes that the supply is 230V, so if it isn't the current may be wrong. The test will exit automatically if the FET heatsink temperature exceeds 100 deg C.

Press any button to move on to the next test.

Test 16.4 – RCD Loop test bits (15mA)

High pitched beep

Message - 'rcd O'

Runs repeatedly the two wire RCD loop test (Live Earth) using 15mA current.

The test assumes that 230V is used – if it is different then the current will not be correct.

If the mains voltage is not connected the display shows the contact symbol open and dashes instead of the bit count, when the mains is detected the contact is shown closed and the test proceeds.

Displays the number of AD bits measured using the LE\_DIV\_214 channel (the display shows the L-PE neon). Pressing the TEST button toggles the measurement to use the high sensitivity NE\_DIV\_21 channel (the N-PE neon comes on). Pressing the TEST button again toggles back to LE\_DIV\_214 channel.

To exit the test press the LOCK button.

Test 16.5 – RCD current self check

High pitched beep

Message - 'xx mA' (xx is the selected current)

Followed by 'Chk'

This test attempts to run the RCD current selected by the rotary switches continuously (Live Earth) – a bit like a very long no trip test. The user must select the desired current before entering the test.

**Warning: this test has the potential to overheat the FET's and/or the 200R resistor, therefore use it only briefly when high currents are selected.**

The (uncalibrated) RCD current measurement range is used to measure the current, and this will give a guide as to whether the rcd current selected is reasonably correct or not. It is OK up to and including 500mA, but overranges at 1A.

Press any button to move on to the next test.

## **Test 17 Loop**

Test 17.1 – Loop balance setup

High pitched beep

Message - 'Pot'

This test repeatedly runs a no load RCD loop test, then measures and displays (in bit form) the resulting output from the two armed loop measurement circuit. The aim is to set the pot to balance the circuit (achieving a reading as close to zero as possible). While there is no mains present then the digital display shows dashes and the '~' symbol flashes.

When mains is present, the display shows the AD reading in digital form and a 'centre zero' analogue representation of the reading on the LCD arc. The test requires that ac mains is present between the Live and Earth terminals on the instrument. The null symbol is displayed during the test. It is possible if the 1u capacitors are at either ends of the spec (10%) that it may be impossible to set the pot.

Press any button to move on to the next test.

Test 17.2 – 25A Loop bits

High pitched beep

Message - '25A'

This test repeatedly runs the 25A loop test, then measures and displays (in bit form) the AD bit output.

Warning: This test is very intensive on the 25A circuit as it repeats the test far more often than would be possible in Customer mode. With a low external loop resistance it will generate a lot of heat quite quickly in the 2.4R resistors. Don't run it for more than a short period with a low external loop resistance or the 2.4R resistors may overheat.

Press any button to move on to the next test.

Test 17.3 – Clean RL1 contacts

High pitched beep

Message – 'CLn'

This test runs the 1A RCD test current for 1 second while rapidly switching RL1 on and off – the current path is switched between Earth and Neutral. The test automatically passes on to Test 18.

## **Test 18 – Dump calibration constants**

High pitched beep  
Message – ‘con’

This test dumps all the calibration constants and eepromed variables out to the serial port (9600,8,N1). The list simply gives the cal constant number alongside its value. The eepromed variables are given alongside an abbreviated name.

A sample printout is provided below:

```
0=.990
1=.990
2=1.005
3=1.005
4=1.005
5=1.000
6=1.000
7=1.026
8=1.026
9=1.026
10=1.026
11=1.000
12=1.004
13=1.000
14=.981
15=1.000
16=.989
17=.989
18=.989
19=.989
20=1.000
21=.988
22=.988
23=.988
24=1.000
25=1.082
26=1.050
27=1.023
28=1.019
29=1.079
30=1.021
31=.993
32=.973
33=.980
34=.971
35=.975
36=1.000
37=1.139
38=1.139
39=1.139
40=1.139
41=1.034
42=1.034
43=.993
44=1.141
45=1.135
46=1.000
47=1.000
48=1.000
49=1.000
50=.000
ohmsnull=.061
ohmszero=.000
kohmsoff=.000
lezero=.110
nlzero=.110
r1zero=.113
r2zero=.287
rnzero=.065
```

At the end of this test the instrument returns to normal operation

---

**Appendix 10 Interboard Connectors**

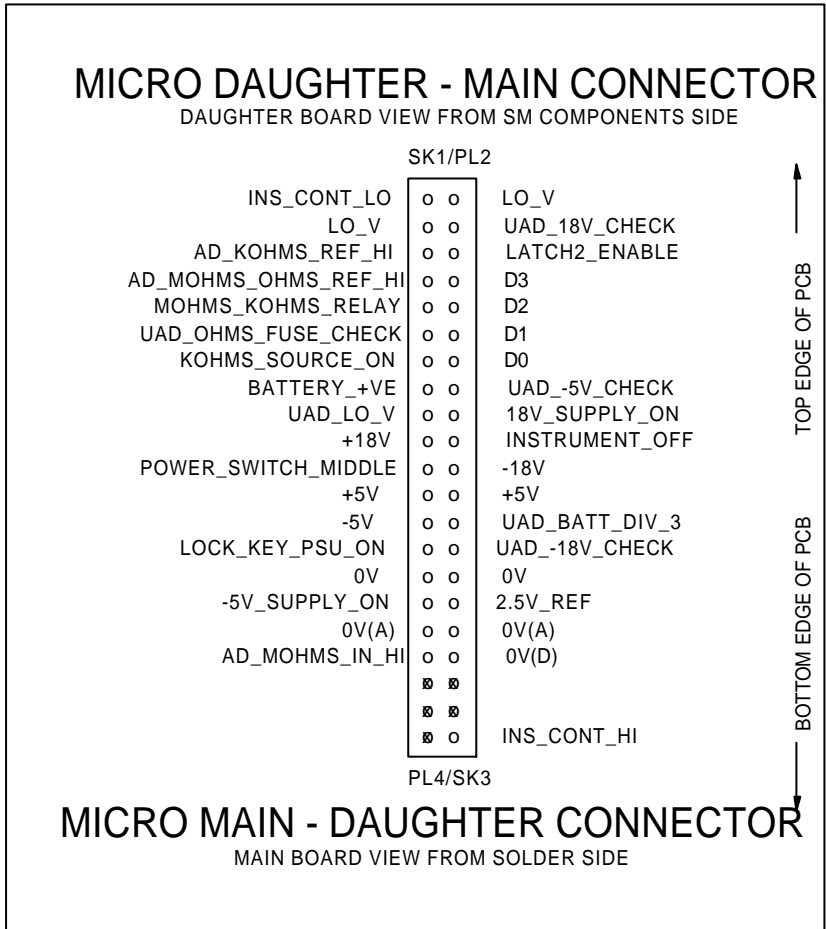

# MICRO MAIN - DAUGHTER CONNECTOR

MAIN BOARD VIEW FROM SM COMPONENTS SIDE

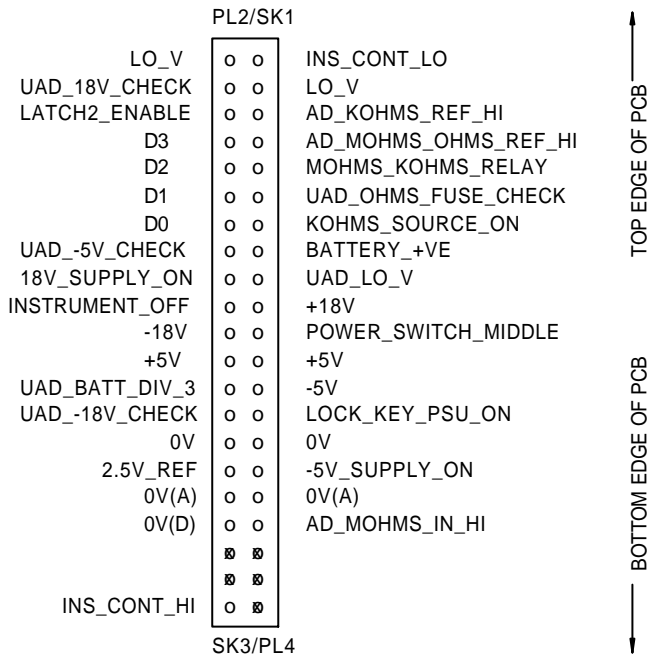

# MICRO DAUGHTER - MAIN CONNECTOR

DAUGHTER BOARD VIEW FROM SOLDER SIDE

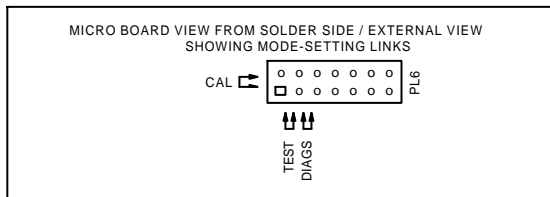
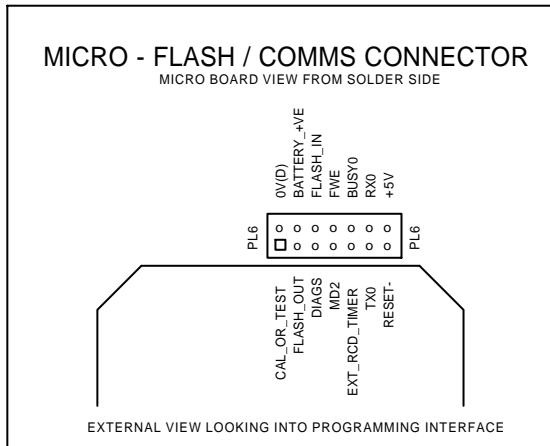
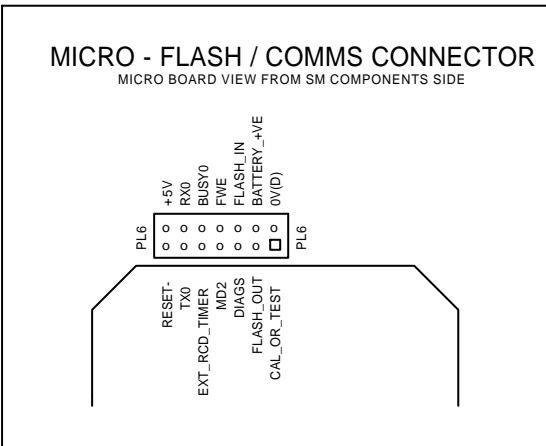







# RELAY DAUGHTER - MAIN CONNECTORS

DAUGHTER BOARD VIEW FROM SM COMPONENT SIDE

LH SIDE OF PCB

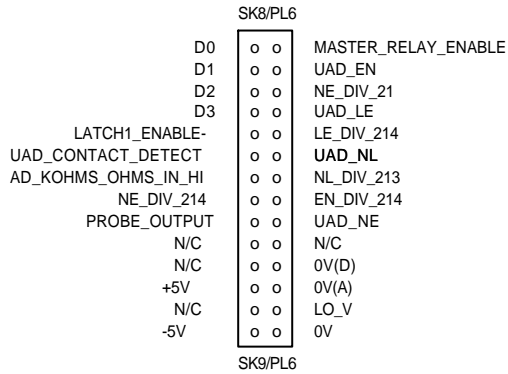
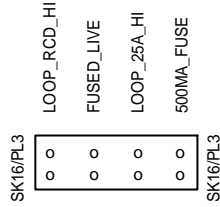
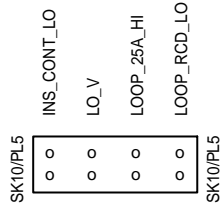

# RELAY MAIN - DAUGHTER CONNECTORS

MAIN BOARD VIEW FROM SOLDER SIDE

## RELAY DAUGHTER - MAIN CONNECTORS

MAIN BOARD VIEW FROM SM COMPONENTS SIDE

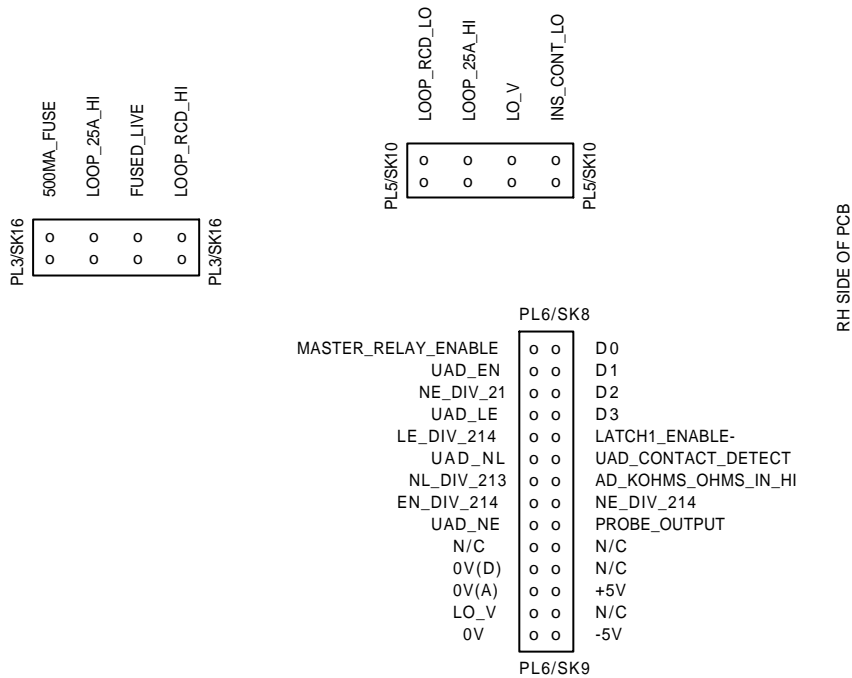

RH SIDE OF PCB

## RELAY MAIN - DAUGHTER CONNECTORS

DAUGHTER BOARD VIEW FROM SOLDER SIDE

## RELAY MAIN - MICRO MAIN CONNECTOR

RELAY BOARD VIEW FROM SM COMPONENTS SIDE

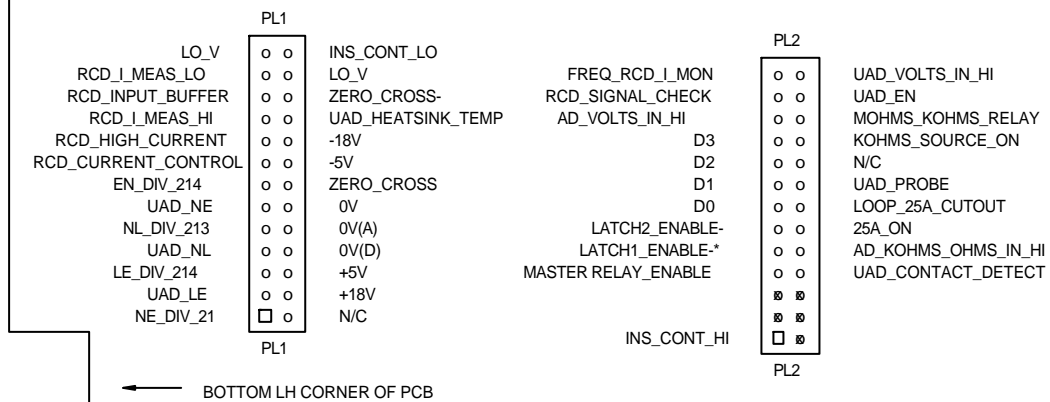



# DISPLAY - MICRO CONNECTOR

DISPLAY BOARD VIEW FROM SOLDER SIDE

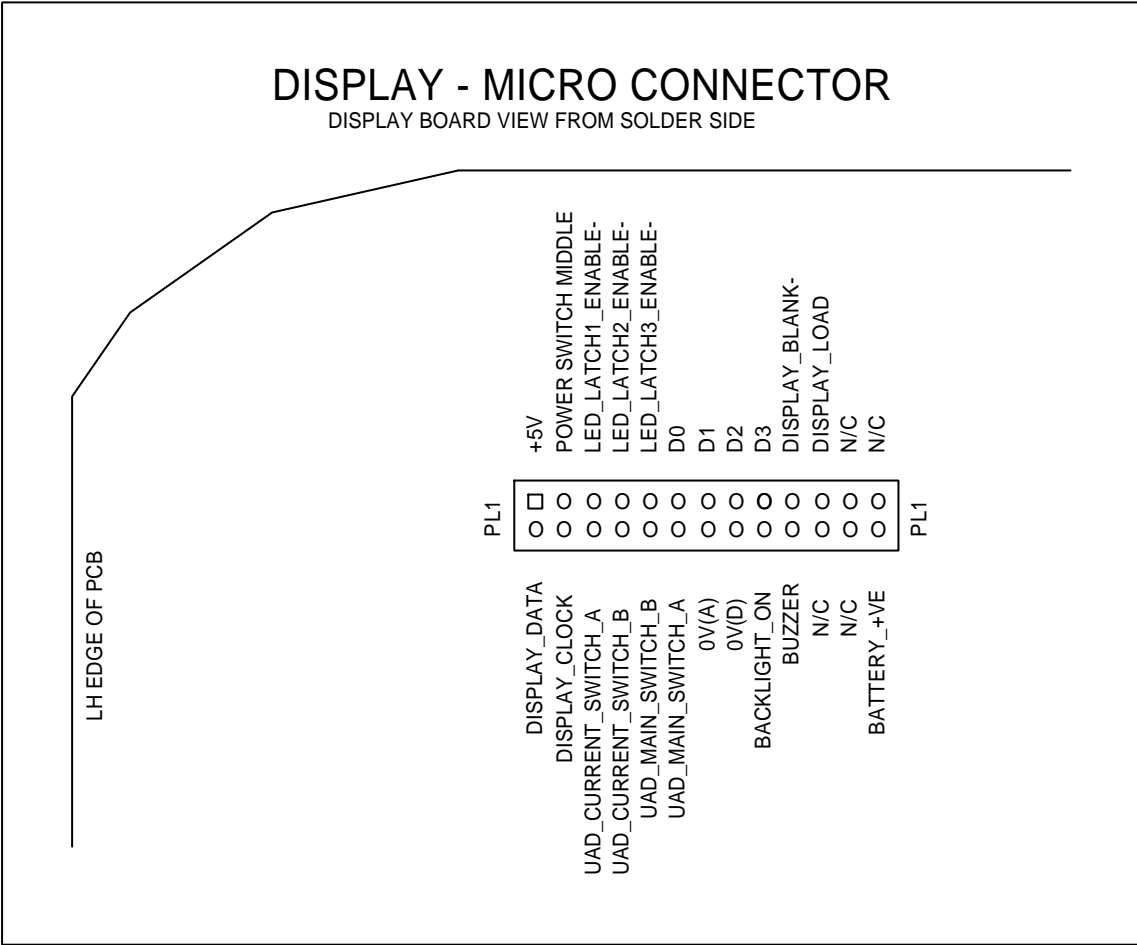

PL1	□	+5V	POWER SWITCH MIDDLE
○	○	LED_LATCH1_ENABLE-	LED_LATCH1_ENABLE-
○	○	LED_LATCH2_ENABLE-	LED_LATCH2_ENABLE-
○	○	LED_LATCH3_ENABLE-	LED_LATCH3_ENABLE-
○	○	D0	D0
○	○	D1	D1
○	○	D2	D2
○	○	D3	D3
○	○	DISPLAY_BLANK-	DISPLAY_BLANK-
○	○	DISPLAY_LOAD	DISPLAY_LOAD
○	○	N/C	N/C
○	○	N/C	N/C
PL1	○	DISPLAY_DATA	DISPLAY_DATA
	○	DISPLAY_CLOCK	DISPLAY_CLOCK
	○	UAD_CURRENT_SWITCH_A	UAD_CURRENT_SWITCH_A
	○	UAD_CURRENT_SWITCH_B	UAD_CURRENT_SWITCH_B
	○	UAD_MAIN_SWITCH_B	UAD_MAIN_SWITCH_B
	○	UAD_MAIN_SWITCH_A	UAD_MAIN_SWITCH_A
	○	0V(A)	0V(A)
	○	0V(D)	0V(D)
	○	BACKLIGHT_ON	BACKLIGHT_ON
	○	BUZZER	BUZZER
	○	N/C	N/C
	○	N/C	N/C
	○	BATTERY_+VE	BATTERY_+VE

## Appendix 11 LCD PINOUT

LCD SEAL

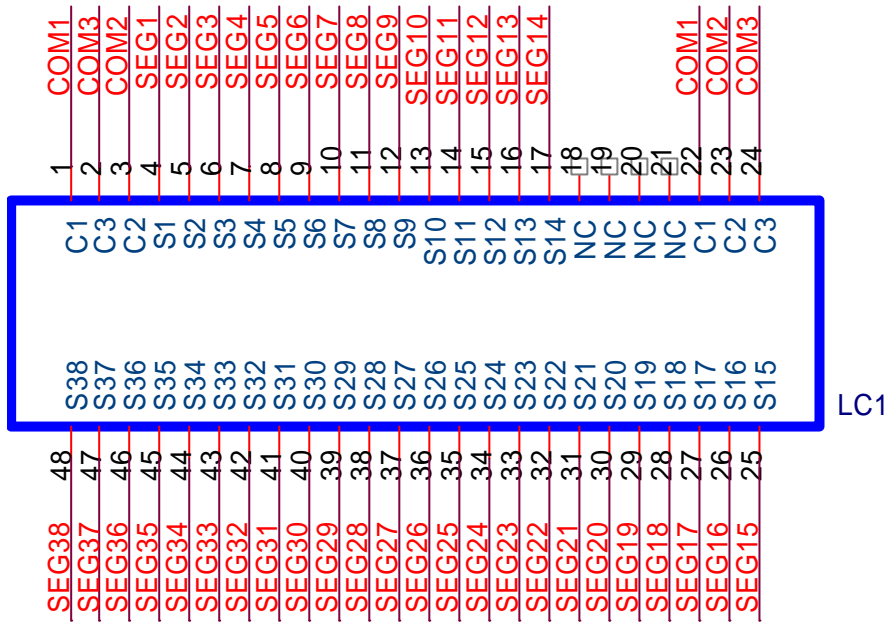

MFT1501 DISPLAY PINOUT					
PIN	DRIVER	COM 1 SEGMENT	COM 2 SEGMENT	COM 3 SEGMENT	
1	COM 1	COM 1	-----	-----	
2	COM 3	-----	-----	COM 3	
3	COM 2	-----	COM 2	-----	
4	DRV 1	S1 LOG INF	S3 NULL	S2 SCALE	
5	DRV 2	S6 LOG ZERO	S4 LIN MARKS	S5 LOG MARKS	
6	DRV 3	S7 LIN 100'S	S8 LIN 10'S	S9 LIN D.P.'S	
7	DRV 4	S11 L-PE NEON	S15 L-N NEON	S13 N-PE NEON	
8	DRV 5	S10 L-PE	S14 L-N	S12 N-PE	
9	DRV 6	S38 BREAKER F	S40 BREAKER C	S39 BREAKER 0	
10	DRV 7	S16 NOISE	S17 FUSE	S18 BATTERY	
11	DRV 8	-----	S41 LIN 100	S19 THERMO	
12	DRV 9	S32 OHMS	S31 k UPPER	S35 ms	
13	DRV 10	S30 AC	S34 A	S37 mA	
14	DRV 11	S29 V	S33 k LOWER	S36 MEGOHM	
15	DRV 12	B48 ARC SEG 48	B47 ARC SEG 47	B46 ARC SEG 46	
16	DRV 13	B43 ARC SEG 43	B44 ARC SEG 44	B45 ARC SEG 45	
17	DRV 14	B42 ARC SEG 42	B41 ARC SEG 41	B40 ARC SEG 40	
18	-----	-----	-----	-----	
19	-----	-----	-----	-----	
20	-----	-----	-----	-----	
21	-----	-----	-----	-----	
22	COM 1	COM 1	-----	-----	
23	COM 2	-----	COM2	-----	
24	COM 3	-----	-----	COM 3	
25	DRV 15	B37 ARC SEG 37	B38 ARC SEG 38	B39 ARC SEG 39	
26	DRV 16	B36 ARC SEG 36	B35 ARC SEG 35	B34 ARC SEG 34	
27	DRV 17	B31 ARC SEG 31	B32 ARC SEG 32	B33 ARC SEG 33	

28		DRV 18		B30 ARC SEG 30		B29 ARC SEG 29		B28 ARC SEG 28
29		DRV 19		B25 ARC SEG 25		B26 ARC SEG 26		B27 ARC SEG 27
30		DRV 20		B24 ARC SEG 24		B23 ARC SEG 23		B22 ARC SEG 22
31		DRV 21		S28 TRIANGLE		3B RH DIG B		3C RH DIG C
32		DRV 22		3A RH DIG A		3G RH DIG G		3D RH DIG D
33		DRV 23		3F RH DIG F		3E RH DIG E		DP3 RH DP
34		DRV 24		S27 0 DEGREE		2B MID DIG B		2C MID DIG C
35		DRV 25		2A MID DIG A		2G MID DIG G		2D MID DIG D
36		DRV 26		2F MID DIG F		2E MID DIG E		DP2 MID DP
37		DRV 27		S26 18 DEGREE		1B LH DIG B		1C LH DIG C
38		DRV 28		1A LH DIG A		1G LH DIG G		1D LH DIG D
39		DRV 29		1F LH DIG F		1E LH DIG E		DP1 LH DP
40		DRV 30		S25 THOUSAND		S23 > OVER		S22 < UNDER
41		DRV 31		S24 - MINUS		S20 Rp		S21 Rc
42		DRV 32		B19 ARC SEG 19		B20 ARC SEG 20		B21 ARC SEG 21
43		DRV 33		B18 ARC SEG 18		B17 ARC SEG 17		B16 ARC SEG 16
44		DRV 34		B13 ARC SEG 13		B14 ARC SEG 14		B15 ARC SEG 15
45		DRV 35		B12 ARC SEG 12		B11 ARC SEG 11		B10 ARC SEG 10
46		DRV 36		B7 ARC SEG 7		B8 ARC SEG 8		B9 ARC SEG 9
47		DRV 37		B6 ARC SEG 6		B5 ARC SEG 5		B4 ARC SEG 4
48		DRV 38		B1 ARC SEG 1		B2 ARC SEG 2		B3 ARC SEG 3

**Appendix 12 Instrument Structure**

**MFT1501 Structure**

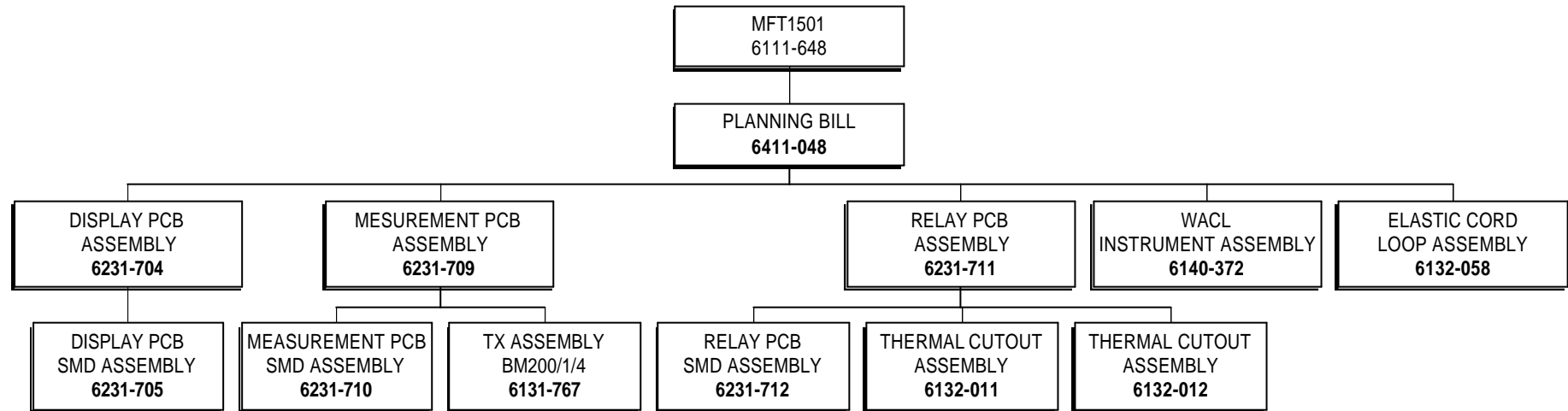

**MFT 1502 Structure**

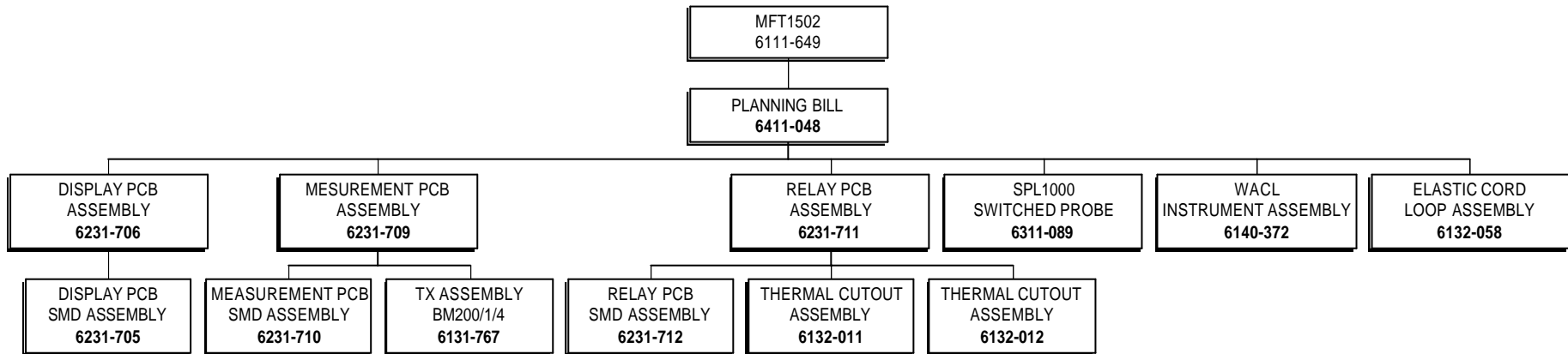



## Appendix 12 Assembly Drawings

### 1. Display PCB

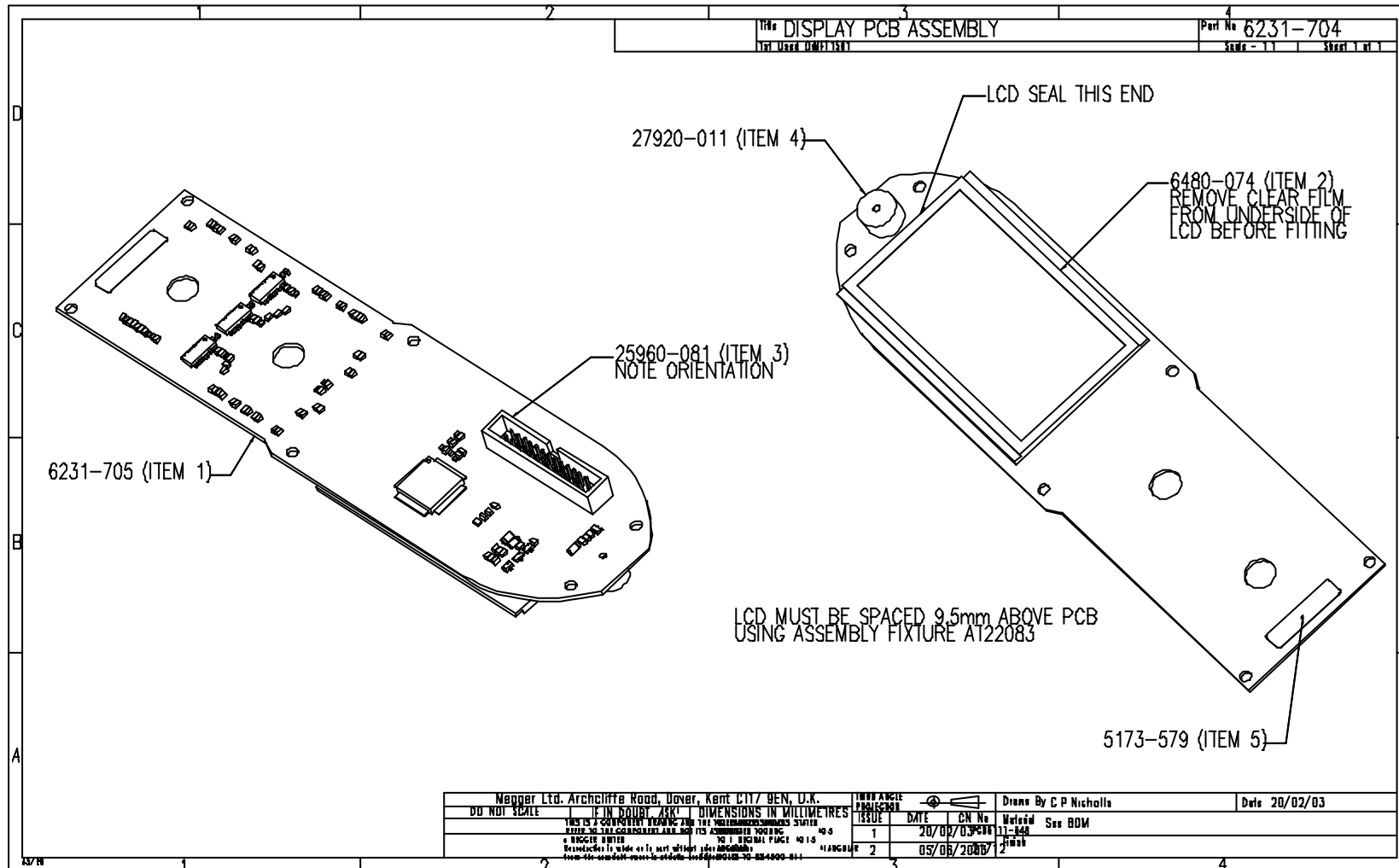



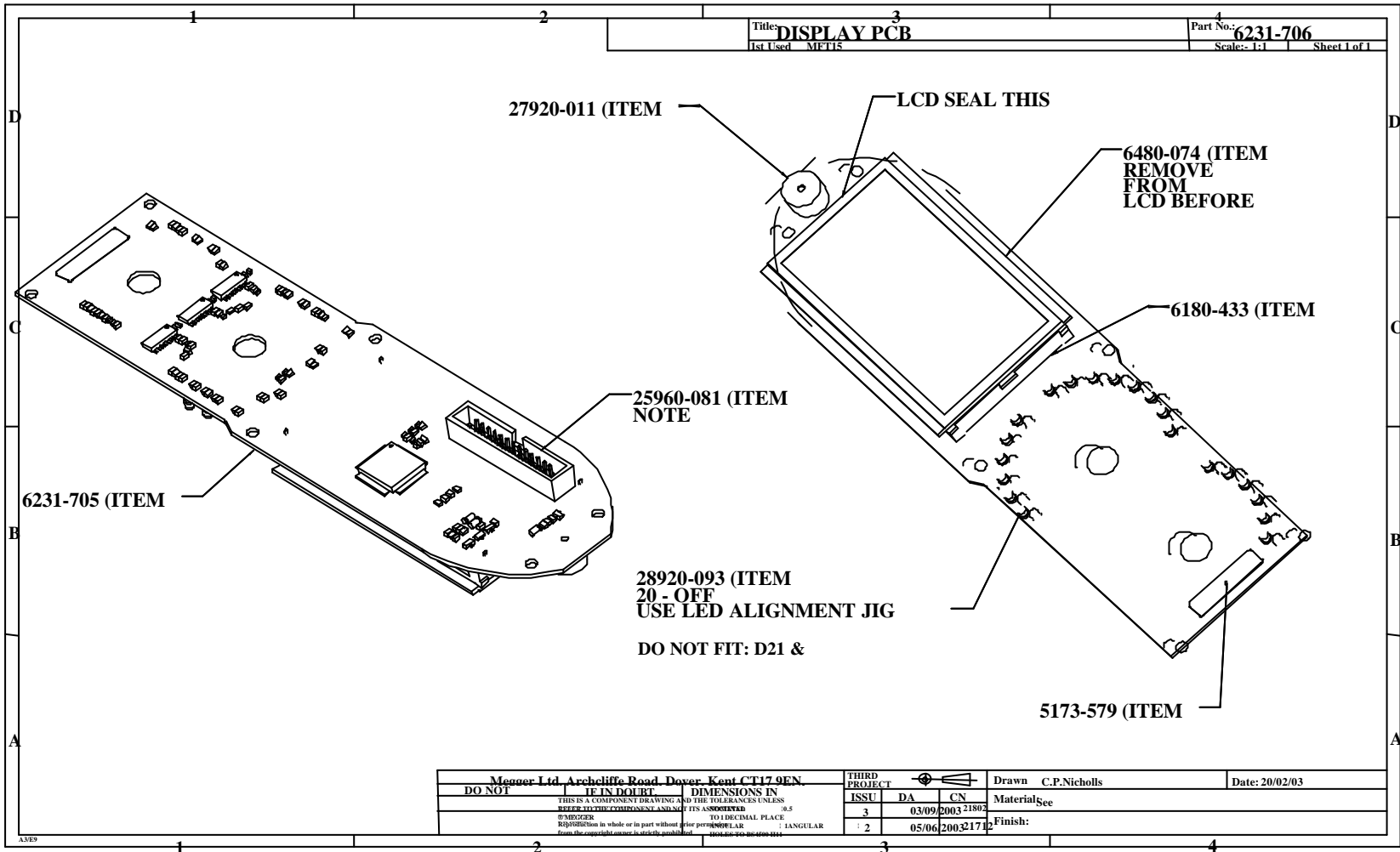

Title: **DISPLAY PCB** Part No.: **6231-706**  
 1st Used: METIS Scale: 1:1 Sheet 1 of 1

Messer Ltd, Archcliffe Road, Dover, Kent, CT17 9EN		THIRD PROJECT		Drawn	C.P.Nicholls	Date:	20/02/03
DO NOT		ISSU	DA	CN	Material		
SEE IN DETAIL DIMENSIONS IN THIS DRAWING AND THE TOLERANCES UNLESS REFER TO THE COMPONENT AND NOT ITS ASSOCIATED SYMBOLS TO DECIMAL PLACE		3	03/09/2003	21807	See		
REPRODUCTION in whole or in part without prior permission from the copyright owner is strictly prohibited.		2	05/06/2003	21712	Finish:		

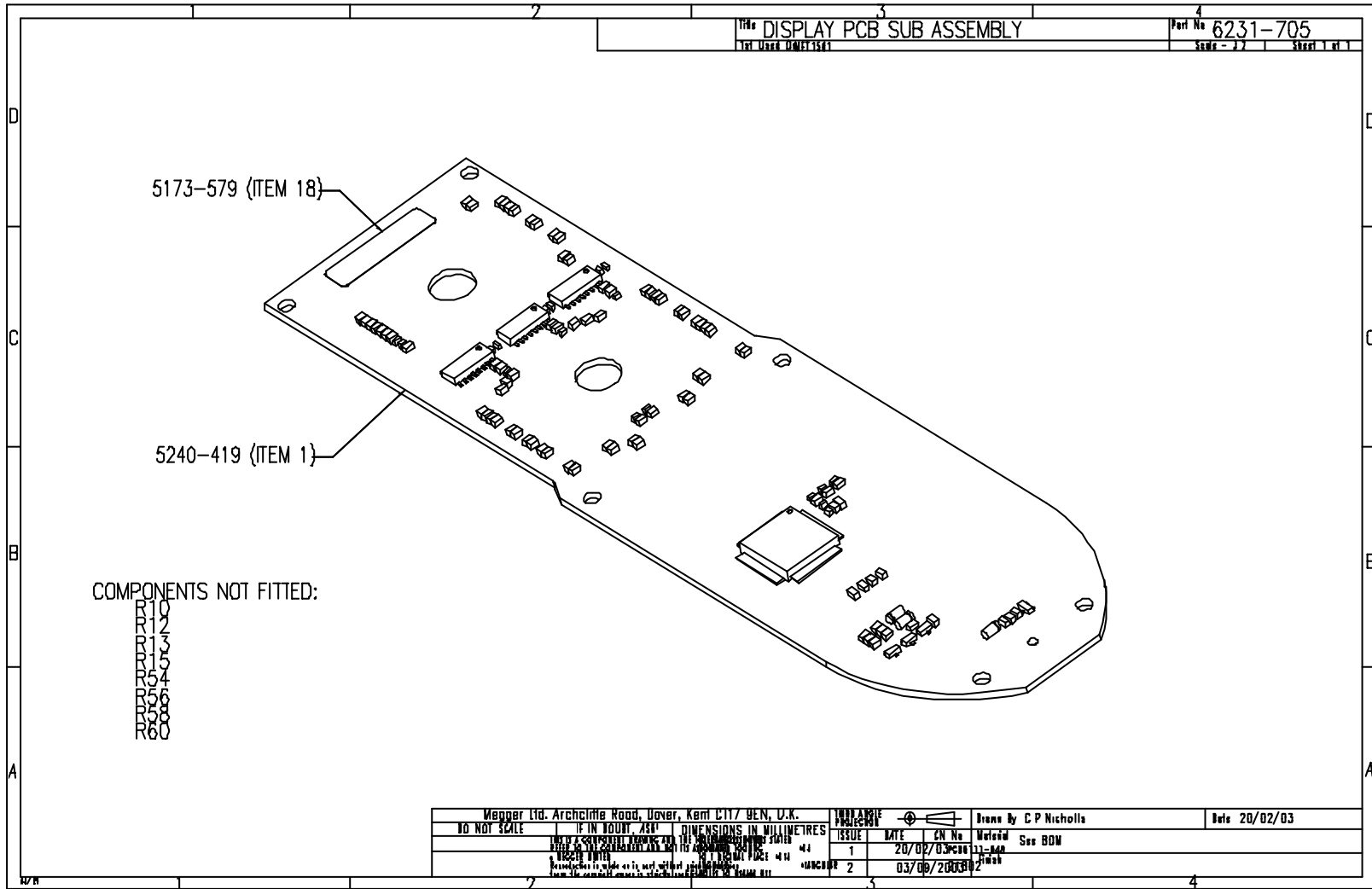

Title: DISPLAY PCB SUB ASSEMBLY  
 Part No: 6231-705  
 Scale: 1:1  
 Sheet 1 of 1

5173-579 (ITEM 18)

5240-419 (ITEM 1)

COMPONENTS NOT FITTED:

5173-579 (ITEM 18)  
 5240-419 (ITEM 1)  
 5173-579 (ITEM 18)  
 5240-419 (ITEM 1)

Megger Ltd, Archcliffe Road, Dover, Kent CT17 9EN, U.K.		DATE	Drawn By C P Nicholls		Date 20/02/03
DO NOT SCALE	IF IN DOUBT, ASK	ISSUE	DATE	EN No	Checked
DIMENSIONS IN MILLIMETRES		1	20/02/03	33-340	See BOM
ALL DIMENSIONS ARE TO UNLESS OTHERWISE SPECIFIED		2	03/09/2003	33-340	
ALL DIMENSIONS ARE TO UNLESS OTHERWISE SPECIFIED					



### 3. Relay PCB

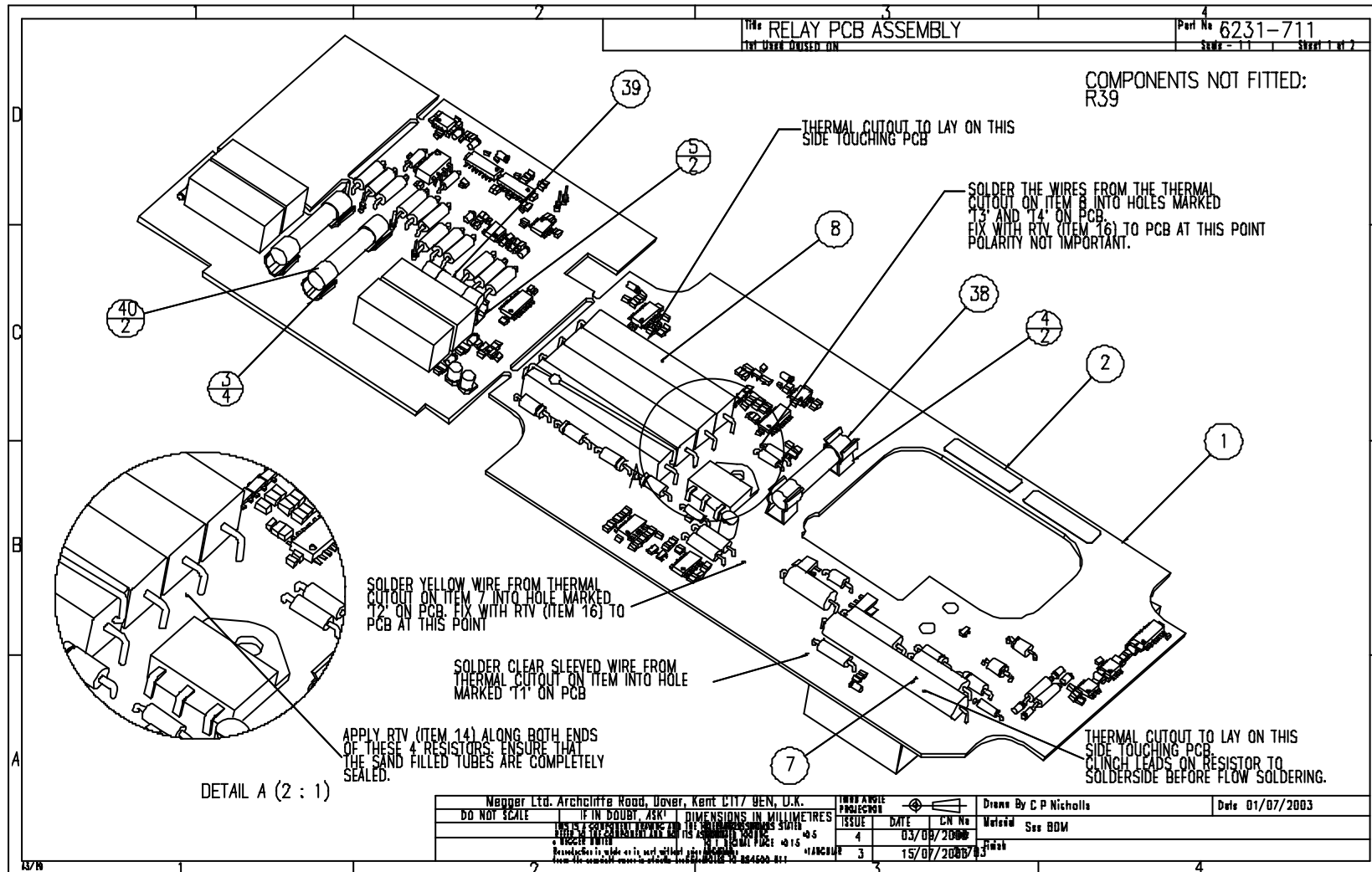

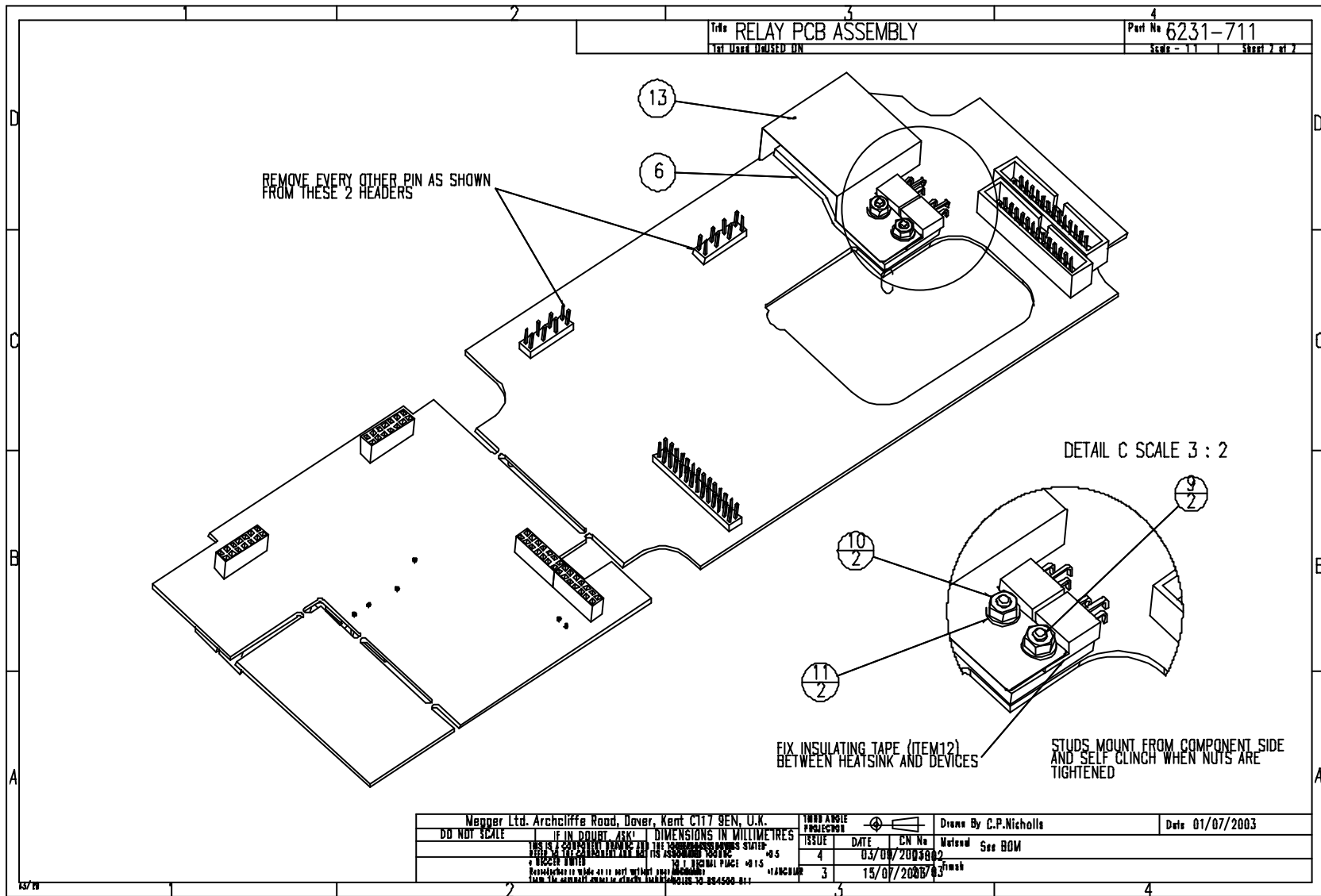

Megger Ltd. Archcliffe Road, Dover, Kent CT17 9EN, U.K.		THIRD ANGLE PROJECTION		Drawn By C.P.Nicholls		Date 01/07/2003	
DO NOT SCALE	IF IN DOUBT, ASK	DIMENSIONS IN MILLIMETRES		ISSUE	DATE	CN No	Method See BOM
THIS IS A PRELIMINARY DRAWING AND IS NOT TO BE USED FOR MANUFACTURE		TOLERANCES UNLESS OTHERWISE SPECIFIED		4	03/07/2003	02	
HOLE DIA. ±0.05		HOLE POSITION ±0.15		3	15/07/2003	03	Finish
HOLE DIA. ±0.05		HOLE POSITION ±0.15		FINISH			

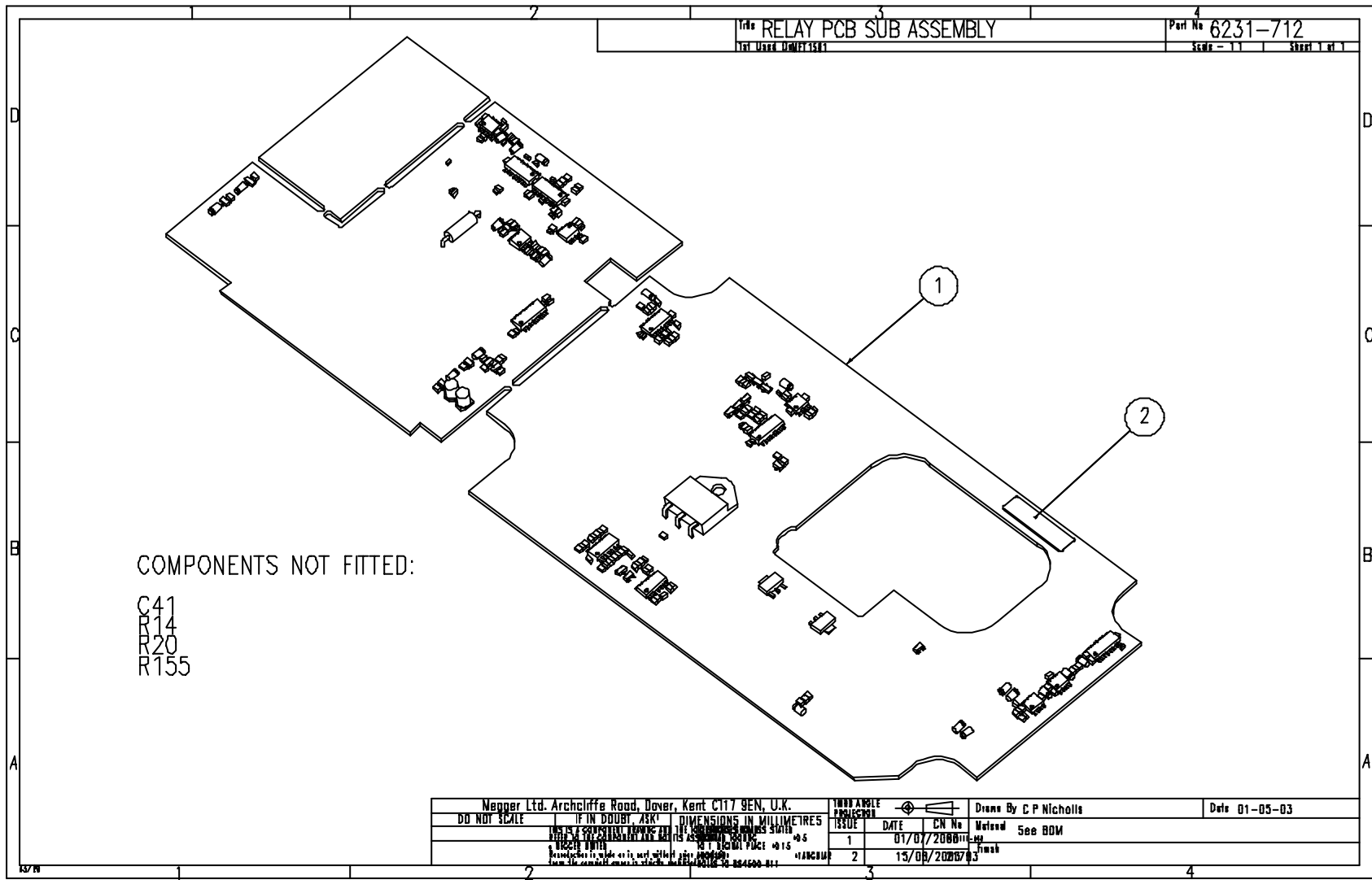

RELAY PCB SUB ASSEMBLY

Part No 6231-712  
Scale - 1:1 Sheet 1 of 1

COMPONENTS NOT FITTED:  
C41  
R14  
R20  
R155

Nipper Ltd. Archcliffe Road, Dover, Kent CT17 9EN, U.K.		UNFINISHED PROJECTION		Drawn By C P Nicholls		Date 01-05-03	
DO NOT SCALE	IF IN DOUBT ASK	DIMENSIONS IN MILLIMETRES		ISSUE	DATE	CN No	Method See BDM
THIS IS AN UNFINISHED DRAWING AND IS NOT TO BE USED FOR MANUFACTURE		1	01/07/2000	1			
DESIGNED BY: C P NICHOLS		2	15/08/2003	2			
CHECKED BY: C P NICHOLS		DRAWN BY: C P NICHOLS					
APPROVED BY: C P NICHOLS		DATE: 01/05/03					











PCB MARKING 'N'  
 BLACK WIRE (W3) SLEEVED WITH S1  
 FROM END NEAREST PCB PIN

PCB MARKING 'E'  
 GREEN WIRE (W5) SLEEVED WITH S1  
 FROM END NEAREST PCB PIN

PCB MARKING 'L'  
 RED WIRE (W1) SLEEVED WITH S1  
 FROM END NEAREST PCB PIN

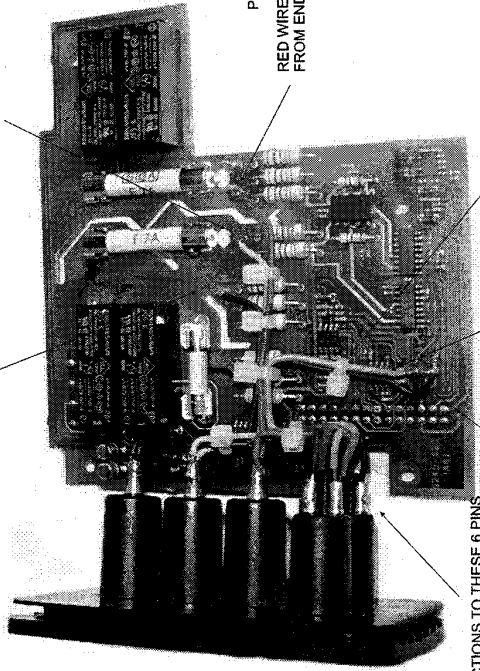

ALL CONNECTIONS TO THESE 6 PINS  
 MUST BE INSULATED WITH RUBBER  
 SLEEVE (ITEM 51)

CABLETIES (ITEM49) 6-OFF IN POSITIONS SHOWN

PCB MARKING 'PB'  
 BLUE WIRE (W6)

PCB MARKING 'OV'  
 BLACK WIRE (W4)

3 RED WIRES (W1 AND W2)  
 BLUE WIRE (W6)

BLACK WIRE (W4)  
 SLEEVE (ITEM 51)

2 GREEN WIRES (W5)

2 BLACK WIRES (W3)

SOLDER THE OTHER ENDS OF  
 THE WIRES AS FOLLOWS:  
 PIN 1 GREEN WIRE (W5)  
 SLEEVED (ITEM 51)  
 PIN 2 BLACK WIRE (W3)  
 SLEEVED (ITEM 51)  
 PIN 3&4 SHORT RED WIRE (W2)  
 SLEEVED (ITEM 51)

THIS WILL LEAVE 5 WIRES (RED, GREEN, BLACK, BLUE, BLACK) TO SOLDER  
 TO THE PCB AS SHOWN ABOVE

ALL WIRES ARE ON WACL (ITEM 37) 6140-372

Mogger Ltd, Archcliffe Road, Dover, Kent CT17 9BA, U.K.		Down By: C.P.Nichols		Date: 31.03.03
DO NOT SCALE	IF IN DOUBT, ASK	IMENSIONS IN MILLIMETRES	DATE	CHINA
THIS IS A CONTROL DRAWING AND NOT FOR MANUFACTURE	NO SCALE	NO SCALE	1	20/03/2003
© Mogger Limited	Reproduction in whole or in part without permission	PCB 11148	PCB 11148	PCB 11148
from the copyright owner is strictly prohibited				
				See BOM
				Print: See Notes



**DISCARD THE PACKING INSERTS FROM ITEM 110 AS THEY ARE NOT REQUIRED.**

CARTON LABEL (ITEM 106) TO BE POSITIONED CENTRALLY ON CARTON LID WITH THE TOP OF THE LABEL THIS END

**MFT1502 PACKING DETAILS**

REMOVE LEAD FROM CARRYBAG AND PACK HERE

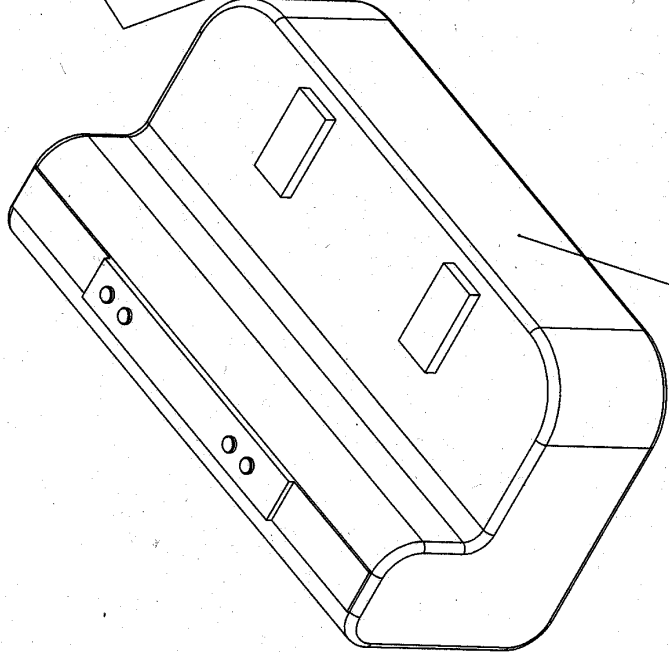

CLOSE LID AND TUCK TONGUE INTO SLOT AND AND FIX WITH TAPE (ITEM 35) IN TWO PLACES ON EITHER SIDE OF TONGUE

POSITION CARTON LABEL (ITEM 106) CENTRALLY ON CARTON FRONT FACE

PACK INSTRUMENT INTO POLYETHENE BAG (ITEM 47) AND SEAL WITH TAPE (ITEM 35) IN TWO PLACES. PLACE INSTRUMENT INSIDE THE CARRY BAG (ITEM 113) CLOSE AND FORM BAG AS SHOWN

PACK BATTERIES IN 3 WIRE LEADSET BAG

Megger Ltd, Acacia Road, Dover, Kent CT17 9BN, U.K.		DISTRIBUTOR		Name: P. J. Nicholls		Date: 31/03/00	
DO NOT SCALE	IF IN DOUBT, ASK	MEASUREMENTS IN MILLIMETRES	DATE	ORDER NO.	NAME	SEE BOM	
REPRODUCTION IN WHOLE OR IN PART WITHOUT THE PERMISSION OF MEGGER LTD IS PROHIBITED.	FOR THE SUPPLY OF THE INSTRUMENT	FOR THE SUPPLY OF THE INSTRUMENT	FOR THE SUPPLY OF THE INSTRUMENT	FOR THE SUPPLY OF THE INSTRUMENT	FOR THE SUPPLY OF THE INSTRUMENT	FOR THE SUPPLY OF THE INSTRUMENT	FOR THE SUPPLY OF THE INSTRUMENT

**Appendix 13 BOM 's /Part numbers**

<b>Display PCB BOM</b>				
<b>6231-706/6231-705</b>				
<b>Qty</b>	<b>PARTNUM</b>	<b>Part Reference</b>	<b>Value</b>	<b>Description</b>
1	6180-433	BL1	0	BACKLIGHT MFT1502
14	32000-029	C1 C2 C4 C5 C6 C7 C8 C9 C10 C12 C13 C15 C16 C18	100.00n	CAP SMD CER- 100nF -20+80%0603
1	32000-025	C3	10.00nF	CAP SMD CER- 10nF 10% 0603
3	32000-027	C11 C14 C17	1.00n	CAP SMD CER. 1nF 10% 0603
3	31000-002	D1 D2 D25	LL4148	DIODE SM LL4148
22	28920-093	D3 D4 D5 D6 D7 D8 D9 D10 D11 D12 D13 D14 D15 D16 D17 D18 D19 D20 D21 D22 D23 D24	LED	LED YELLOW ULTRA-BRITE 3MM
1	30100-013	IC1	MSM9004-02GS-BK	IC LCD DRIVER MSM9004-02
3	30000-101	IC2 IC3 IC4	74HC259	IC DECODER ADDRESSABLE 74HC259
1	6480-074	LC1	0	LCD MFT1501 TRANSFECTIVE
1	25960-081	PL1	0	HEADER 26-WAY DIL 0.1"INCH BOX
10	33000-037	R1 R2 R3 R6 R7 R8 R9 R81 R83 R85	10.00K	RES SM- 10K MF 1% 0.063W 0603
1	33000-041	R4	68.00K	RES SM- 68K MF 1% 0.063W 0603
1	33000-036	R5	6.80K	RES SM- 6K8 MF 1% 0.063W 0603
2	33000-044	R10 R15	1.00M	RES SM' 1M MF 1% 0.063W 0603
7	33000-028	R11 R12 R13 R14 R78 R79 R80	33.00R	RES SM; 33R MF 1% 0.063W 0603
14	33000-031	R16 R17 R62 R64 R65 R67 R68 R69 R71 R72 R74 R75 R76 R77	1.00K	RES SM- 1K MF 1% 0.063W 0603
44	33000-068	R18 R19 R20 R21 R22 R23 R24 R25 R26 R27 R28 R29 R30 R31 R32 R33 R34 R35 R36 R37 R38 R39 R40 R41 R42 R43 R44 R45 R46 R47 R48 R49 R50 R51 R52 R53 R54 R55 R56 R57 R58 R59 R60 R61	300.00R	RES SM;300R MF 1% 0.063W 0603
7	33000-070	R63 R66 R70 R73 R82 R84 R86	30.00K	RES SM- 30K MF 1% 0.063W 0603
2		SW1 SW2	SW 24 POS DS PCB	
2	31000-004	TR1 TR2	BCF29	TRANSISTOR PNP DRG 6180-395
2	31000-001	TR3 TR4	BCW32	TRANSISTOR NPN DRG 6180-396
1	27920-011	WD1	0	BUZZER ELECTRO-MAG TRANSDUCER



**MEASUREMENT PCB BOM  
6231-709**

Qty	PARTNUM	Part Reference	Value	Description
3	32000-022	C1 C3 C39	10.00uF	CAP SMD TANT- 10uF 20% 7343
65	32000-029	C2 C4 C6 C7 C8 C9 C11 C12 C15 C17 C21 C22 C23 C24 C28 C29 C30 C31 C32 C34 C35 C41 C43 C45 C50 C51 C52 C53 C55 C59 C60 C62 C63 C64 C65 C66 C67 C68 C69 C71 C72 C73 C74 C75 C76 C77 C78 C79 C81 C82 C83 C84 C86 C88 C89 C90 C92 C93 C94 C96 C97 C99 C100 C101 C102	100.00n	CAP SMD CER- 100nF -20+80%0603
4	32000-030	C5 C36 C56 C57	100.00pF	CAP SMD CER 100pF 5% 0603
6	32000-023	C10 C13 C18 C27 C40 C80	10.00uF	CAP SMD ELEC 10uF 16V 0405
1	27889-950	C14	10.00u	CAP ELEC'- 10uF 16Vdc 20%
1	32000-021	C16	100.00uF	CAP SMD TANT*100uF 20% 7343
1	32000-022	C19	10.00uF	CAP SMD TANT- 10uF 20% 7343
1	32000-023	C20	10.00uF	CAP SMD ELEC 10uF 16V 0405
3	32000-027	C25 C37 C38	1.00n	CAP SMD CER. 1nF 10% 0603
2	32000-025	C26 C107	10.00nF	CAP SMD CER- 10nF 10% 0603
1	26970-109	C33	220.00u	CAP ELEC"220uF 16Vdc 20%
1	32000-021	C42	100.00uF	CAP SMD TANT*100uF 20% 7343
1	26970-087	C44	47.00n	CAP FILM-- 47nF 1500Vdc 20%
3	32000-027	C46 C70 C95	1.00n	CAP SMD CER. 1nF 10% 0603
3	32000-035	C47 C54 C61	1.00u	CAP SMD FILM, 1.0uF 5% 2824
3	32000-034	C48 C49 C58	330.00n	CAP SMD FILM- 330nF 20% 2824
2	32000-031	C85 C87	33.00p	CAP SMD CER 33pF 5% 0603
2	32000-025	C91 C98	10.00nF	CAP SMD CER- 10nF 10% 0603
3	32000-029	C103 C104 C105	100.00n	CAP SMD CER- 100nF -20+80%0603
1	32000-032	C106	10.00pF	CAP SMD CER 10pF 5% 0603
4	31000-021	D1 D2 D3 D7	MBRS130LT3	DIODE SM SCHOT 1A MBRS130LT3
37	31000-002	D4 D5 D6 D8 D9 D10 D13 D14 D15 D16 D18 D28 D30 D31 D32 D33 D35 D36 D37 D38 D39 D40 D41 D42 D43 D44 D45 D46 D47 D48 D49 D50 D51 D52 D53 D54 D55	LL4148	DIODE SM LL4148
6	28863-082	D11 D19 D22 D24 D26 D27	1N4007	DIODE,1N4007 1A-1000V
1	31000-014	D12	BZX84C33TA	ZENER SM. 33V 5% 0.5W
2	28920-062	D17 D21	1N5339B	ZENER 5.0W 5% 5.6V 1N5339B
2	28863-160	D20 D25	BA159	DIODE,1A 1000V BA159
1	28920-064	D23	BY448	DIODE,1500V FAST RECOV. BY448
1	31000-029	D29	ZRC250	IC BANDGAP 2.5V1% ZRC250 SOT23
1	31400-004	D34	BZX84C5V1	ZENER .35W 5% 5.1V SOT23 BZX84
1	35000-005	FS1	0	FUSE, 1.25A RESETTABLE SMD
1	30100-020	IC1	LT1617ES5-1	IC CONVERTER DC/DC LT1617
1	30100-019	IC2	LT1615ES5-1	IC CONVERTER DC/DC LT1615
1	30100-021	IC3	LT1578CS8	IC CONVERTER DC/DC LT1578
1	30000-103	IC6	MAX860	IC CONVERTER +5to-5V MAX860IUA
3	30000-101	IC7 IC13 IC29	74HC259	IC DECODER ADDRESSABLE 74HC259
1	31000-011	IC8	OP77GS	IC OP-AMP OPA177GS
6	30000-023	IC9 IC10 IC12 IC14 IC18 IC32	4051	IC MULTIPLEXER ANOLOG 4051
1	30000-007	IC11	ICL7109CMH	IC ADC 12 BIT 3 STATE BINARY
1	30000-087	IC16	AD622AR	IC OP-AMP AD622AR
1	30000-138	IC19	DS1267S-100	IC DUAL DIGITAL POT DS1267
1	30000-092	IC23	TLE2021CD	IC OP-AMP LOW-POWER TLE2021CD
1	30000-102	IC26	24C64	IC EEPROM 8Kx8 24C64 SO8

1	30000-139	IC27	HD64F3062BF25	IC MICROCONTRLR HD64F3062BF25
1	6139-175	IC28	MFT	PROGRAMMED DEVICE MFT1501
1	30000-052	IC4	62	IC OP-AMP J-FET 062
2	31000-005	IC5 IC21	LM339	IC COMPARITOR QUAD LM339 (S/M)
1	30000-015	IC20	74HC123	IC DUAL MONO 74HC123 (NOT A.)
2	30000-024	IC15 IC17	4053	IC ANALOG SWITCH 3x2IN-PT 4053
2	30000-015	IC30 IC31	74HC123	IC DUAL MONO 74HC123 (NOT A.)
2	30000-084	IC22 IC25	TLE2022CD	IC OP-AMP DUAL TLE2022CD
1	30000-071	IC24	DG411	IC ANALOG SWITCH SPSTx8 411DY
3	35000-004	L1 L2 L3	0	INDUCTOR 15uH 2A
1	25960-045-03	PL1	0	3 WAY- 3PIN HEADER
4	25960-066-14	PL2 PL3 PL4 PL6	0	14 WAY- 14PIN DIL HEADER
1	25960-066-10	PL5	0	10 WAY- 10PIN DIL HEADER
3	25960-126	PL7 PL8 PL9	0	HEADER 26-WAY DIL 0.1" IDC
29	33000-042	R1 R4 R8 R9 R17 R24 R200 R202 R109 R119 R121 R122 R123 R133 R240 R243 R244 R246 R250 R251 R152 R254 R255 R256 R259 R167 R183 R186 R195	100.00K	RES SM-100K MF 1% 0.063W 0603
30	33000-070	R2 R3 R5 R18 R20 R26 R31 R33 R35 R51 R60 R61 R62 R63 R74 R81 R98 R201 R204 R218 R221 R126 R127 R139 R140 R247 R159 R172 R190 R199	30.00K	RES SM- 30K MF 1% 0.063W 0603
84	33000-037	R6 R13 R16 R19 R21 R22 R23 R30 R32 R36 R40 R42 R45 R54 R55 R56 R65 R66 R68 R75 R83 R88 R92 R99 R203 R104 R205 R207 R108 R208 R209 R110 R210 R112 R212 R213 R214 R115 R215 R216 R217 R118 R219 R120 R220 R223 R124 R224 R125 R226 R227 R128 R228 R129 R229 R130 R230 R231 R132 R232 R233 R234 R235 R236 R237 R238 R142 R248 R149 R153 R253 R154 R157 R162 R163 R166 R168 R174 R178 R188 R191 R193 R194 R198	10.00K	RES SM- 10K MF 1% 0.063W 0603
3	33000-071	R7 R10 R59	300.00K	RES SM-300K MF 1% 0.063W 0603
5	33000-040	R11 R135 R136 R158 R176	47.00K	RES SM- 47K MF 1% 0.063W 0603
4	33000-038	R12 R15 R52 R53	22.00K	RES SM- 22K MF 1% 0.063W 0603
3	33000-029	R14 R78 R94	100.00R	RES SM;100R MF 1% 0.063W 0603
15	33000-069	R25 R27 R34 R37 R46 R67 R76 R79 R89 R91 R96 R116 R117 R131 R143	3.00K	RES SM- 3K MF 1% 0.063W 0603
31	33000-044	R28 R38 R39 R50 R57 R69 R77 R82 R87 R107 R222 R137 R138 R145 R245 R146 R249 R150 R151 R260 R261 R264 R169 R170 R173 R175 R179 R180 R184 R196 R197	1.00M	RES SM' 1M MF 1% 0.063W 0603
5	33000-068	R29 R41 R47 R48 R70	300.00R	RES SM;300R MF 1% 0.063W 0603
18	33000-031	R43 R49 R58 R73 R80 R86 R206 R113 R134 R239 R241 R242 R144 R252 R155 R156 R161 R185	1.00K	RES SM- 1K MF 1% 0.063W 0603
3	33000-035	R44 R225 R148	4.70K	RES SM- 4K7 MF 1% 0.063W 0603
14	33000-027	R64 R93 R97 R141 R147 R160 R262 R263 R164 R165 R171 R177 R181 R192	10.00R	RES SM; 10R MF 1% 0.063W 0603
1	33000-041	R71	68.00K	RES SM- 68K MF 1% 0.063W 0603
1	26900-134	R72	470.00K	RES-470K0 MF 1% 0.25W MFR4
2	33000-036	R84 R85	6.80K	RES SM- 6K8 MF 1% 0.063W 0603
1	26837-130	R90	10.00M	RES' 10M0 MG 1% 0.5W VR37
2	26900-161	R95 R106	24.00K	RES- 24K0 MF 1% 0.25W MFR4
1	25980-067	RL1	0	RELAY DPDT 5V 40mA G6A

2	26900-253	R100 R101	12.00R	RES; 12R0 MF 1% 0.25W MFR4
4	26900-001	R102 R103 R111 R114	10.00R	RES; 10R0 MF 1% 0.25W MFR4
1	33000-028	R105	33.00R	RES SM; 33R MF 1% 0.063W 0603
1	33000-040	R211	47.00K	RES SM- 47K MF 1% 0.063W 0603
2	33000-068	R257 R258	300.00R	RES SM;300R MF 1% 0.063W 0603
5	33000-031	R265 R266 R268 R269 R270	1.00K	RES SM- 1K MF 1% 0.063W 0603
2	33000-044	R271 R272	1.00M	RES SM' 1M MF 1% 0.063W 0603
1	34000-008	R182	100.00K	POT SMD 100K 25% 0.15W 4mmSQ
2	26837-104	R187 R189	22.00K	RES- 22K0 MF 0.1% 0.25W 200V
3	25965-171	SK1 SK2 SK3	0	SOCKET-DIL 14-WAY (LOW PROF)
1	25975-107	SW1	0	SWITCH PUSH TACTILE SPNO PCB
13	31000-001	TR1 TR5 TR6 TR7 TR9 TR10 TR11 TR12 TR13 TR15 TR18 TR23 TR26	BCW32	TRANSISTOR NPN DRG 6180-396
2	31000-004	TR3 TR27	BCF29	TRANSISTOR PNP DRG 6180-395
1	31100-004	TR4	FDN304P	TRANSISTOR MOSFET P, FDN304P
1	31100-005	TR8	PHD3055E	TRANSISTOR MOSFET N, PHD3055E
1	6131-767	TX1	300.00R	TX ASSY BM200/1/4 BM400s
7	31000-016	TR14 TR16 TR17 TR19 TR20 TR21 TR22	2N7002	TRANSISTOR FET N-CHAN 2N7002
1	31000-022	TR2	IRF7306	IC MOSFET X 2 0.10HM IRF7306
1	35000-009	XL1	0	CRYSTAL,10MHz HC49/4HSMX

Relay PCB BOM 6231-711				
Qty	PARTNUM	Part Reference	Value	Description
18	32000-029	C1 C3 C6 C7 C12 C13 C17 C18 C20 C27 C28 C29 C30 C31 C32 C33 C34 C35	100.00n	CAP SMD CER- 100nF -20+80%0603
3	32000-027	C2 C10 C11	1.00n	CAP SMD CER. 1nF 10% 0603
1	27889-956	C4	47.00u	CAP ELEC'- 47uF 16Vdc 20%
9	32000-030	C5 C9 C22 C23 C25 C26 C36 C37 C38	100.00pF	CAP SMD CER 100pF 5% 0603
3	32000-025	C8 C16 C41	10.00nF	CAP SMD CER- 10nF 10% 0603
2	32000-023	C14 C15	10.00uF	CAP SMD ELEC 10uF 16V 0405
4	32000-029	C19 C24 C39 C40	100.00n	CAP SMD CER- 100nF -20+80%0603
2	32000-030	C21 C42	100.00pF	CAP SMD CER 100pF 5% 0603
19	31000-002	D1 D2 D3 D4 D5 D6 D7 D12 D15 D19 D20 D21 D22 D23 D24 D25 D26 D27 D28	LL4148	DIODE SM LL4148
2	28863-082	D8 D9	1N4007	DIODE,1N4007 1A-1000V
6	27920-039	D10 D11 D14 D16 D17 D18	P6KE440P	ZENER TVS.600W 440V UniDir
1	28940-044	D13	BTW69-1000	SILICON CONTROL RECTIFIER 1000V
1	28920-047	D31	SA12CA	ZENER TVS.12V 500W BiDi SA12CA
1	25950-039	FS1	0	FUSE-500mA(F) 500V 1.5kA 32mm
1	25413-284	FS2	0	FUSE, 1A(F)HBC 20mm IEC127-1
2	25411-854	FS3 FS4	0	FUSE, 7A(F)HBC 600V 50A 32mm
1	30000-089	IC4	LM50CIM3	IC TEMPERATURE SENSOR LM50CIM3
2	30000-101	IC7 IC10	74HC259	IC DECODER ADDRESSABLE 74HC259
1	30000-106	IC8	ICL7611	IC OP-AMP CMOS 8xSOIC ICL7611
1	30000-010	IC11	TL061CD	IC OP-AMP J-FET L.POWER 061CD
3	31000-005	IC5 IC6 IC9	LM339	IC COMPARITOR QUAD LM339 (S/M)
2	30000-084	IC1 IC2	TLE2022CD	IC OP-AMP DUAL TLE2022CD
1	30000-066	IC3	4052	IC ANALOG SWITCH 2P4W 4052
1	20000-672	IC15	TLC27M2CP	IC OP-AMP CMOS DUAL TLC27M2CP
2	30000-052	IC12 IC16	62	IC OP-AMP J-FET 062
2	30000-024	IC13 IC14	4053	IC ANALOG SWITCH 3x2IN-PT 4053
1		LKD2	LINK DUMMY	
2	25960-081	PL1 PL2	0	HEADER 26-WAY DIL 0.1"INCH BOX
2	25960-066-14-08	PL3 PL5	0	14 WAY- 14PIN DIL HEADER
1	25960-066-28	PL6	0	28 WAY- 28PIN DIL HEADER
6	25960-118	PL7 PL8 PL9 PL10 PL11 PL12	0	HEADER 1-WAY (CLIP-IN)
8	33000-044	R1 R34 R48 R50 R69 R73 R112 R113	1.00M	RES SM' 1M MF 1% 0.063W 0603
41	33000-037	R2 R4 R5 R8 R9 R10 R11 R15 R27 R28 R31 R35 R37 R38 R43 R47 R49 R54 R55 R57 R66 R67 R68 R92 R94 R97 R101 R102 R109 R110 R123 R124 R127 R128 R129 R132 R137 R139 R142 R149 R150	10.00K	RES SM- 10K MF 1% 0.063W 0603
10	33000-042	R3 R29 R30 R36 R51 R52 R64 R65 R86 R91	100.00K	RES SM-100K MF 1% 0.063W 0603
10	33000-027	R6 R7 R41 R78 R111 R120 R126 R130 R140 R143	10.00R	RES SM; 10R MF 1% 0.063W 0603
11	33000-069	R12 R20 R58 R60 R62 R71 R95 R103 R104 R151 R152	3.00K	RES SM- 3K MF 1% 0.063W 0603
2	26837-090	R13 R16	10.00K	RES- 10K MF 0.1% 0.25W 200V
4	33000-070	R14 R56 R105 R121	30.00K	RES SM- 30K MF 1% 0.063W 0603
1	26837-070	R17	20.00K	RES- 20K MF 0.1% .25W
2	26837-175	R18 R25	3.30R	RES; 3R3 WW 1% 3W PAC03

1	26837-131	R19	200.00R	RES;200R WW 5% 12W
3	33000-071	R21 R85 R88	300.00K	RES SM-300K MF 1% 0.063W 0603
1	33000-041	R22	68.00K	RES SM- 68K MF 1% 0.063W 0603
3	26837-130	R24 R118 R158	10.00M	RES' 10M0 MG 1% 0.5W VR37
1	26836-084	R26	62.00R	RES; 62R0 MF 2% 0.75W MFR5
9	26837-130	R32 R33 R122 R131 R133 R135 R141 R145 R148	10.00M	RES' 10M0 MG 1% 0.5W VR37
2	26900-005	R39 R40	15.00R	RES; 15R0 MF 1% 0.25W MFR4
19	33000-031	R42 R53 R59 R61 R63 R70 R72 R79 R87 R89 R90 R93 R96 R98 R99 R100 R107 R117 R119	1.00K	RES SM- 1K MF 1% 0.063W 0603
1	26900-028	R44	130.00R	RES;130R0 MF 1% 0.25W MFR4
7	33000-040	R45 R46 R115 R116 R125 R144 R147	47.00K	RES SM- 47K MF 1% 0.063W 0603
2	33000-068	R74 R75	300.00R	RES SM;300R MF 1% 0.063W 0603
2	33000-028	R76 R77	33.00R	RES SM; 33R MF 1% 0.063W 0603
1	33000-036	R80	6.80K	RES SM- 6K8 MF 1% 0.063W 0603
1	26837-115	R81	2.40R	RES; 2R40 WW 5% 7W KF216
3	26837-133	R82 R83 R84	2.40R	RES; 2R4 WW 5% 12W
4	25980-057	RL1 RL2 RL3 RL4	0	RELAY SPDT 380 VAC 8A JS5-K**
3	26837-066	R106 R108 R114	750.00K	RES-750K MG 5% 0.5W VR37
2	33000-029	R134 R138	100.00R	RES SM;100R MF 1% 0.063W 0603
2	26837-189	R136 R146	4.70M	RES' 4M7 MF 0.1% 0.6W MRS25
2	33000-031	R153 R154	1.00K	RES SM- 1K MF 1% 0.063W 0603
3	33000-044	R155 R156 R157	1.00M	RES SM' 1M MF 1% 0.063W 0603
2	25418-217	SK3 SK4	0	FUSE CLIP 6.3mm 15A PCB 102071
2	25955-010	SK7 SK11	300.00R	FUSE CLIP 5mm DIA. LOW PROFILE
2	25965-171	SK8 SK9	0	SOCKET-DIL 14-WAY (LOW PROF)
2	25965-171-08	SK10 SK16	0	SOCKET-DIL 14-WAY (LOW PROF)
4	25955-028	SK12 SK13 SK14 SK15	300.00R	FUSE CLIP 11/4" LOW PROFILE
1	29550-006	TR1	MTP2P50E	TRANSISTOR MOSFET P, MTP2P50E
1	29550-007	TR2	2SK2662	TRANSISTOR MOSFET N, 2SK2662
1	31100-006	TR3	NDT452AP	TRANSISTOR MOSFET P, NDT452AP
1	31000-031	TR4	HUF75307T3ST	TRANSISTOR MOSFET N, 75307
11	31000-001	TR5 TR6 TR7 TR11 TR12 TR13 TR14 TR16 TR17 TR18 TR19	BCW32	TRANSISTOR NPN DRG 6180-396
4	31000-004	TR8 TR9 TR10 TR15	BCF29	TRANSISTOR PNP DRG 6180-395

## **Appendix 14 Display Messages & Buzzer Tones**

### **1. Alphabetical List**

Ad	Diagnostics Ad converter (7109) test
bAC	Diagnostics push buttons test – bACklight button
bAt	Diagnostics bAttery test
bAt	Last-ditch dead bAttery warning
CAL	Instrument is in CALibrate mode
cct	Diagnostics contact/cct detect test
cct	Buzzer contact/cct detect threshold setting – no longer used
chE	Diagnostics rcd current ChEck - self-measurement reading
CLn	Diagnostics test - CLeans the relays
cLr	Eeprom variables CLeared
con	Diagnostics transmit calibration constants test
CUS	Instrument is in CUStomer mode
Cut	Thermal Cutout operated during rcd test
cut	Thermal cutout operated during loop test
Cxy	Diagnostics Uad test – Channel number xy (x = uad channel, y = mux channel)
dAH	Diagnostics eeprom test – sdA stuck High
dAL	Diagnostics eeprom test – sdA stuck Low
db	Diagnostics data bus test
dEb	Instrument is in dEbug mode
dEC	Instrument dECalibration performed
dEg	Diagnostics push buttons test – dEgree button
diA	Instrument is in diAgnostics mode
diA	diAgnostics test range
diS	Diagnostics diSplay test
EEP	Diagnostics EEProm test
Err	Diagnostics eeprom test – other Error
Exy	Error number xy occurred
FrE	Diagnostics FrEQUENCY measurement test
FuS	FuSe blown
Fxy	Fault number xy occurred
grE	Diagnostics probe test – led is grEen
HI	Diagnostic ohms/kohms range check – HI range
HI	Diagnostics relay test – HI relay
Hot	25A range cutout operated due to Hot resistor
hng	System has hung up
Hxy	Diagnostics data bus test - status in Hex x = high order nibble, y = low order nibble
inu	Diagnostics inverter test

L	Diagnostics relay test – L relay
L-E	Loop test – L-E measurement phase
LLL	Diagnostic rotary switch test – Left hand (function) switch
L-n	Loop test – L-n measurement phase
LO	Diagnostics relay test – LO relay
LO	Diagnostic ohms/kohms range check – LO range
LOC	Diagnostics push buttons test – LOCK button
LO(V)	LOW Voltage insufficient supply voltage for rcd test
ndb	no display board detected(!)
nE	Diagnostics relay test – nE relay
nEU	nEUtral connection open circuit during 3-wire loop test
n-E	Loop test – n-E measurement phase
nid	Diagnostic ohms/kohms range check – middle range
nni	nmi occurred (not in customer/final test mode)
no	no trip occurred during rcd I/5I/DC/Ramp test
noS	Instrument is in customer mode with no Shutdown
nrb	no relay board detected
OFF	Instrument about to switch OFF
oFF	Diagnostics probe test – led is oFF
oFF	Diagnostics inverter test – inverter oFF
oFF	Diagnostics relay test – relays oFF (disabled)
oFF	Buzzer put into silent (oFF) mode
on	Buzzer put into normal (on) mode
PbS	Diagnostics Push buttonS test
PLd	PLd programme error
Png	Pinger operated on loop test
Pot	Diagnostic loop test – adjust Pot to balance arms
Prb	Diagnostics Probe test
Prb	+ fuse symbol - Probe fuse blown
r0	Diagnostics serial interface test - receive in channel 0 (comms)
rcd	Diagnostics rcd test
rEd	Diagnostics probe test – led is rEd
rF	Diagnostics serial interface test - receive in Flash channel (channel 1)
rLy	Diagnostics reLay test
rng	Diagnostic ohms/kohms range check
rot	Diagnostic rotary switch test
rrr	Diagnostic rotary switch test – right hand (current) switch
rSt	Instrument reSetting
SEr	Diagnostics SErial interface test
SIL	Instrument is in SILent mode
Sng	Rcd test – Single cycle measurement phase
StH	A/d converter Status line stuck High
StL	A/d converter Status line stuck Low
t0	Diagnostics serial interface test - transmit from channel 0
tES	Diagnostics push buttons test – teSt button
tES	Instrument is in tES mode
tF	Diagnostics serial interface test - transmit from Flash channel
thr	Diagnostics push buttons test – threshold button
toP	Diagnostic ohms/kohms range check – toP range
trA	Instrument is in test mode with trAnsmit on
trp	Unexpected trip during rcd test
UAd	Diagnostics Micro (U) Ad converter test

UAd Diagnostics probe test – UAd reading  
ubo Micro-(u)-board-only diode fitted  
unc Instrument is uncalibrated  
Uol Rcd test - Voltage measurement phase

°C Diagnostics heatsink temperature reading in °C  
??? Diagnostics inverter test – o/p voltage cannot be measured  
15(mA) Diagnostics rcd 15mA current test  
25(A) Diagnostics 25A test  
>50(V) High loop resistance, >50V likely to be present on earth conductor



## **2. List by Category**

### **Messages likely during Normal Operation**

OFF	Instrument about to switch OFF
oFF	Buzzer put into silent (oFF) mode
on	Buzzer put into normal (on) mode
no	no trip occurred during rcd I/5I/DC/Ramp test
trp	Unexpected trip occurred during rcd ½ I test
Cut	Thermal Cutout operated during rcd test
cut	Thermal cutout operated during loop test
Prb	+ fuse symbol - Probe fuse blown
FuS	FuSe blown
Png	Pinger operated on loop test
bAT	Last-ditch dead bAttery warning

### **Additional messages likely with untested instrument**

unc	Instrument is uncalibrated
Exy	Error number xy occurred
nrb	no relay board detected
ndb	no display board detected(!)
PLd	PLd programme error
hng	System has hung up
nmi	nmi occurred
rSt	Instrument reSetting
bAt	battery warning
StL	A/d converter Status line stuck Low
StH	A/d converter Status line stuck High

### **Special Modes etc.**

CAL	Instrument is in CALibrate mode
dEb	Instrument is in dEbug mode
diA	Instrument is in diAgnostics mode
tES	Instrument is in tESt mode
ubo	Micro-(u)-board-only diode fitted
dEC	Instrument dECalibration performed
CLr	Eeprom variables CLeared
Fxy	Fault number
Uol	Rcd test - Voltage measurement phase
sng	Rcd test – single cycle measurement phase
rcd	Rcd test – rcd current phase
L-n	Loop test – L-n measurement phase
L-E	Loop test – L-E measurement phase
n-E	Loop test – n-E measurement phase

### **Mode –change Screen.**

CAL	CALibrate mode
CUS	CUStomer mode
dEb	dEbug mode
noS	Customer mode with no Shutdown
SIL	Customer mode but SILent
tES	Final tESt mode
trA	Final test mode with trAnsmit on
SEt	New mode has been SEt

### **Diagnostics Mode**

diA	diAgnostics
diS	Diagnostics diSplay test
dB	Diagnostics data Bus test
Hxy	Diagnostics data bus test - status in Hex
UAd	Diagnostics Micro (U) Ad converter test
Cxy	Diagnostics Uad test – Channel number xy
Ad	Diagnostics Ad converter (7109) test
SEr	Diagnostics SErial interface test
r0	Diagnostics serial interface test - receive in channel 0 (comms)
rF	Diagnostics serial interface test - receive in Flash channel (channel 1)
t0	Diagnostics serial interface test - transmit from channel 0
tF	Diagnostics serial interface test - transmit from Flash channel
inu	Diagnostics inverter test
oFF	Diagnostics inverter test – inverter oFF
cct	Diagnostics contact/cct detect test

Diagnostics Mode – cont'd

EEP	Diagnostics EEPROM test
dAL	Diagnostics eeprom test – sDA stuck Low
dAH	Diagnostics eeprom test – sDA stuck High
Err	Diagnostics eeprom test – other Error
rng	Diagnostic ohms/kohms range check
LO	Diagnostic ohms/kohms range check – LO range
mid	Diagnostic ohms/kohms range check – middle range
HI	Diagnostic ohms/kohms range check – HI range
toP	Diagnostic ohms/kohms range check – toP range
rot	Diagnostic rotary switch test
LLL	Diagnostic rotary switch test – Left hand (function) switch
rrr	Diagnostic rotary switch test – right hand (current) switch
Prb	Diagnostics Probe test
UAd	Diagnostics probe test – Uad reading
rEd	Diagnostics probe test – led is rEd
grE	Diagnostics probe test – led is grEen
oFF	Diagnostics probe test – led is oFF
bAt	Diagnostics bAttery test
PbS	Diagnostics Push buttonS test
tES	Diagnostics push buttons test – teSt button
thr	Diagnostics push buttons test – threshold button
dEg	Diagnostics push buttons test – dEgree button
bAC	Diagnostics push buttons test – bACklight button
LOC	Diagnostics push buttons test – LOCk button
rLy	Diagnostics reLay test
L	Diagnostics relay test – L relay
nE	Diagnostics relay test – nE relay
HI	Diagnostics relay test – HI relay
LO	Diagnostics relay test – LO relay
oFF	Diagnostics relay test – relays oFF (disabled)
FrE	Diagnostics FrEQUENCY measurement test
°C	Diagnostics heatsink temperature reading in °C
15mA	Diagnostics rcd 15mA current test
rcd	Diagnostics rcd test
chE	Diagnostics rcd test – rcd current chEck
Pot	Diagnostic loop test – adjust Pot to balance arms
25A	Diagnostics 25A test
CLn	Diagnostics CLean relays
con	Diagnostics transmit calibration constants test

## **MFT1501 Buzzer Tones**

### **Warnings – 1kHz (fairly loud)**

1kHz for 250ms – push button press which is invalid (has no effect)  
1kHz for 250ms – pld programme error given when selecting rcd/loop range  
1kHz for 250ms – invalid rcd test selection (requested current too large)  
1kHz for 250ms – several beeps, warning of 1kV insulation test starting  
1kHz for 500ms – fuse blown during ohms/buzzer/insulation test  
1kHz for 500ms – warning during startup that micro-board-only diode is fitted  
1kHz for 500ms – warning during startup that relay board was not detected  
1kHz for 500ms – warning during startup that display board was not detected  
1kHz for 500ms – warning during startup that instrument is not calibrated  
1kHz for 500ms – warning during startup of pld programme error  
1kHz for 500ms – warning of volts unexpectedly too high when starting ohms/buzzer/insulation test  
1kHz for 1s – an error has occurred  
1kHz beeping with equal on/off - volts are too high for test during pretest

### **Continuity Buzzer 2kHz (loudest tone)**

2kHz continuous – continuity buzzer

### **Auto loop test – 3kHz (quieter than 1kHz warning)**

3kHz for 100ms – several beeps , warning of a auto loop test starting

### **Keypress beep – 4kHz**

4kHz for 25ms – push button press which is valid (performs a function)  
4kHz for 1000ms – long degree button press to select/deselect ‘s’ type rcds

### **Selective breaker mode**

4kHz for 1000ms – long degree button press to select/deselect ‘s’ type rcds

### **Calibrate Mode – 3kHz/6kHz**

6kHz for 100ms – acknowledge successful calibration  
3kHz for 500ms – warning of calibration failure

### **Diagnostics Mode – 8kHz (very quiet)**

8kHz for 500ms – announces a diagnostic test  
8kHz continuous – buzzer test tone during 1<sup>st</sup> diagnostic test

## **Appendix 15 Key Presses and Combinations**

### **1. Backlight key**

#### **1.1.Customer mode**

Backlight key – Toggles Display + Label Backlighting on/off  
Backlight key + Lock key – Toggles intelligent backlighting on/off

#### **1.2.Final Test mode**

Backlight key – Toggles Display + Label Backlighting on/off  
Backlight key + Lock key – Toggles intelligent backlighting on/off

#### **1.3.Calibrate mode**

Backlight key + Lock key – Clears a single calibration constant

#### **1.4.Diagnostics mode**

Step to next diagnostic test  
Backlight key + Degree key + Threshold key – Resets instrument

#### **1.5. All modes, except diagnostics**

Backlight key + Lock key or Test key, while selecting invalid RCD switch position – Mode Display/Change

### **2. Threshold key**

#### **2.1.Customer mode**

Threshold key – Step up to next Buzzer threshold

#### **2.2.Final Test mode**

Threshold key – Step up to next Buzzer threshold

#### **2.3.Calibrate mode**

Threshold key - Decrease value of resistance or current on rcd/loop  
Threshold key + Lock key – At startup, clears eeprom variables  
Threshold key + Lock key + Degree key – At startup, clears eeprom variables and calibration constants

#### **2.4.Diagnostics mode**

Step to next diagnostic test group  
Threshold key + Backlight key + Degree key – Resets instrument

#### **2.5 All modes, except diagnostics**

Threshold key + Lock key or Test key, while selecting invalid RCD switch position – Mode Display/Change

### **3. Degree key**

#### **3.1.Customer mode**

Degree key – Toggle 0/180 on I/5I/DC RCD tests  
Degree key. long press – Toggle General/Selective rcd mode

#### **3.2.Final Test mode**

Degree key – Toggle 0/180 on I/5I/DC RCD tests  
Degree key. long press – Toggle General/Selective rcd mode

#### **3.3.Calibrate mode**

Degree key - Increase value of resistance or current on rcd/loop  
Degree key – Adjust ohms zero reading  
Degree key + Lock key – At startup, clears all calibration constants  
Degree key + Lock key + Threshold key – At startup, clears eeprom variables and calibration constants

#### **3.4.Diagnostics mode**

Degree key - Step to next diagnostic test group  
Degree key + Threshold key + Backlight key – Resets instrument

#### **3.5 All modes, except diagnostics**

Degree key + Lock key or Test key, while selecting invalid RCD switch position – Mode Display/Change

## **4. Test key**

### **4.1.Customer mode**

Test key or probe test key – Start Insulation test  
Test key or probe test key - Start RCD test  
Test key or probe test key - Repeat Loop test  
Test key or probe test key - Ohms null on/off  
Test key or probe test key – Toggle continuity Buzzer mode silent/noisy  
Test key + Lock key – In ‘OFF’ position, do battery check

### **4.2.Final Test mode**

Test key – At startup, extend display test  
Test key or Probe Test key – Start/Stop Insulation test  
Test key or Probe Test key - Start RCD test  
Test key or Probe Test key - Repeat Loop test  
Test key or Probe Test key – Ohms null on/off  
Test key or Probe Test key – Toggle continuity Buzzer mode silent/noisy  
Test key + Lock key – In ‘OFF’ position, do battery check

### **4.3.Calibrate mode**

Test key – At startup, extend display test  
Test key or Probe Test key – Start/Stop Insulation test  
Test key or Probe Test key - Start RCD test  
Test key or Probe Test key - Repeat Loop test  
Test key or Probe Test Key – Ohms null on/off  
Test key or Probe Test Key – Toggle continuity Buzzer mode silent/noisy

### **4.4.Diagnostics mode**

Test key - Step to next diagnostic test type  
Test key - Toggle buzzer on/off during display test  
Test key - Toggle displayed quantity voltage/current on some tests

### **4.5 All modes, except diagnostics**

**Test key + Degree key or Threshold key or Backlight key, while selecting invalid RCD switch position – Mode Display/Change**

## **5. Lock key**

### **5.1.Customer mode**

Lock key – Switch instrument on  
Lock key – During Insulation test, engage/cancel test button lock  
Lock key + Test key or Probe Test key – Start Ins test with test button lock  
Lock key + Test key – In ‘OFF’ switch position, do battery check

### **5.2.Final Test mode**

Lock key – Switch instrument on  
Lock – During Insulation test, engage/cancel test button lock  
Lock key + Test key or Probe Test key – Start Ins test with test button lock  
Lock key + Test key – In ‘OFF’ switch position, do battery check  
Lock key + Backlight key – Toggles intelligent backlighting on/off

### **5.3.Calibrate mode**

Lock key – Calibrate single point  
Lock key + Backlight key – Clear a single calibration constant  
Lock key + Threshold key – At startup, clears eeprom variables  
Lock key + Degree key – At startup, clears all calibration constants  
Lock key + Threshold key + Degree key – At startup, clears eeprom variables  
and all calibration constants

### **5.4.Diagnostics mode**

Lock key - Step to next diagnostic test

### **5.5 All modes, except diagnostics**

**Lock key + Degree key or Threshold key or Backlight key, while selecting invalid RCD switch position – Mode Display/Change**

## **Appendix 16 Remote Control Mode**

### **Outline Description**

The MFT1501 can be operated remotely from a pc via an RS232 interface, which will enable most of the Calibration & Final Test sequences to be done under automatic control, if required. Test results can also be transmitted from the instrument for validation, or for subsequent printing of calibration certificates. The serial link is combined with the flash programming interface as a 14-pin DIL connector, accessible from the battery compartment. The following actions will be achievable under remote control...

1. Operating mode selection, i.e. Customer mode, Calibrate, Final Test etc.
2. Main switch setting, i.e. Insulation, Volts, etc.
3. Current switch setting.
4. Operation of pushbuttons.
5. Sending a test result from the MFT1501.
6. Sending the battery status from the MFT1501
7. Other, such as Probe Led setting, Diagnostics, etc.

### **Calibration**

The MFT1501 will be designed to allow as much as possible of the calibration to be carried out on the fully assembled instrument. One or two adjustments may be required at board level, but these will be kept to a minimum.

In Calibrate mode, one or more of the pushbuttons will have auxiliary functions, and will be used to generate internal correction factors which will be stored in non-volatile memory. Since this process uses only the normal instrument front-panel controls, it will be possible to do this all under remote control.

### **Final Test Mode**

The intention is that almost all of the final test will be able to be automated. Rotary switches and pushbuttons can be controlled, so that any test required can be selected and initiated. The result can be requested and will be transmitted exactly as it appeared on the display. Thus the readings can be verified against limits, and retained for printing on a calibration certificate if required.

Battery status can also be sent on demand.

Certain tests on the final instrument may require external measurements, such as battery current, insulation test voltage, and possibly rcd test currents.

A hardware trigger signal will be provided in the interface for synchronizing of test gear for rcd trip-timing.

### **Basic operation of remote mode**

The basic premise is to keep the protocol as simple as possible, with no complex software handshaking required. All commands sent to the MFT1501 will consist of a single alphanumeric character. If the command is valid, the MFT1501 will echo it back to the sender, followed by a delimiter, such as a space. If the command is invalid, it will be ignored. The receive buffer in the instrument is very small, and any overflow will be lost.

At switch-on, the MFT1501 will default to 'Local mode', and transmit a 'ready' character ('?') when all appropriate setting up has been done. At this point, the instrument responds only to the 'remote mode' command. When this has been received, the rotary switches and the pushbuttons on the instrument are disabled and the instrument can be fully controlled via the serial link.

Readings sent from the MFT1501 will be exactly as displayed, and followed by a delimiter. Certain other messages will also be sent, such as confirmation of a calibration.

Example

To start a 500V insulation test and obtain a result

1. Transmit the command to select remote mode.
2. Receive echoed character, plus delimiter.
3. Transmit the command to select 500V insulation test position on the rotary switch.
4. Receive echoed character, plus delimiter.
5. Wait 1s for MFT1501 to stabilize.
6. Transmit the command to press the test button.
7. Receive echoed character, plus delimiter.
8. Wait a couple of seconds for the reading to stabilize.
9. Transmit the command to request the result
10. Receive echoed character, plus delimiter.
11. Receive result, such as "5.01MR" plus delimiter.

## Communications.

The comms will be standard RS232 with the following settings...

- 9600 baud asynchronous
- 8-bit data
- 2 stop bits
- no parity checking

There will be a 'MFT1501 busy' signal available for limited hardware handshaking, but this is unlikely to be required. All commands and data will use standard ascii characters.

### **MFT1501 Control Codes**

ACTION	COMMAND	ACTION	COMMAND
SELECT REMOTE MODE	'{'	BACKLIGHT KEY	'b'
SELECT LOCAL MODE	'}'	DEGREE KEY	'd'
		BUZZER THRESHOLD KEY	'h'
OPEN COMMENT MODE	('	LOCK KEY PRESS	'l'
CLOSE COMMENT MODE	)'	LOCK KEY RELEASE	'm'
		S-TYPE RCD MODE ON/OFF	's'
SELECT 4 POLE EARTH (DIAGNOSTICS)	'A'	TEST KEY PRESS	't'
SELECT 3 POLE EARTH (DIAGNOSTICS)	'B'	TEST KEY RELEASE	'u'
SELECT 1000V INSULATION TEST	'C'		
SELECT 500V INSULATION TEST	'D'	REQUEST BATTERY STATUS	'p'
SELECT 250V INSULATION TEST	'E'	REQUEST SINGLE RESULT	'q'
SELECT BUZZER RANGE	'F'		
SELECT OHMS RANGE	'G'	CUSTOMER MODE	'o'
SELECT VOLTS RANGE	'H'	CALIBRATE MODE	'l'
SELECT RCD HALF I, NO-TRIP TEST	'I'	FINAL TEST MODE	'2'
SELECT RCD I, TRIP TEST	'J'	DEBUG MODE	'3'
SELECT RCD 5I TEST	'K'		
SELECT RCD I TRIP RAMP TEST	'L'	TURN ON TRANSMISSION OF RESULTS	'x'
SELECT RCD DC SENSITIVE	'M'	TURN OFF TRANSMISSIONS	'y'
SELECT XTRA LOOP, 3-WIRE TEST	'N'		
SELECT 25A LOOP TEST	'O'		
SELECT PSC TEST	'P'		
SELECT 1000mA RCD CURRENT	'Q'	PROBE LOCAL MODE	'a'
SELECT 500mA RCD CURRENT	'R'	SET PROBE LED RED	'r'
SELECT 300mA RCD CURRENT	'S'	SET PROBE LED GREEN	'e'
SELECT 100mA RCD CURRENT	'T'	SET PROBE LED OFF	'o'
SELECT 30mA RCD CURRENT	'U'	SET PROBE TO VOLTS CHECK	'v'
SELECT 10mA RCD CURRENT	'V'		
SELECT DIAGNOSTICS	'W'	QUIT DIAG TEST	ESC
SWITCH OFF	'X'		
RESET	Z	RESET	Z



**MFT1501 Messages**

<b>MFT1501 MESSAGE</b>	<b>MEANING</b>	<b>MFT1501 MESSAGE</b>	<b>MEANING</b>
'?’	READY	'A'	AMPS
'	DELIMITER	'M'	MEG-
'batf'	FLAT BATTERY	'R'	OHMS
'batg'	GOOD BATTERY		
'batl'	LOW BATTERY	V	VOLTS
'cal'	CALIBRATION DONE	'c'	CUTOUT OPERATED
'decal'	DECALIBRATION	'w'	SUPPLY FAIL
		'f'	FUSE BLOWN
'-	NEGATIVE SIGN	'n'	RCD FET TOO HOT
'.'	DECIMAL POINT	'k'	KIL-
'>	OVERRANGE		
'<	UNDERRANGE	'm'	MILLI-
		's'	SECONDS
		'z'	SHUTDOWN
		'~'	AC SIGN

## **Appendix 17 Operating Modes**

### **1. Customer Mode**

This mode is the default mode which occurs at switch-on.

### **2. Calibrate Mode**

Lock key initiates semi-automatic calibration.

Negative readings which are normally suppressed are now displayed

Insulation test has locking test button action.

Insulation measurement range on display is 0k to 999M.

There are certain differences in Pretest...

Pretest LE voltage is displayed and calibrated in 1000V insulation position.

Pretest LN voltage is displayed and calibrated in 500V insulation position.

Pretest NE voltage is displayed and calibrated in 250V insulation position.

### **3. Final Test Mode**

Almost the same as Customer Mode except that certain extra tests are enabled under remote control (e.g. display check). Battery message response time is reduced to enable more rapid testing. Rcd test time may be increased to facilitate test current measurement.

Insulation test has locking test button action.

### **4. Debug Mode**

This is a non-customer mode which can be used for fault-finding.

### **5. Diagnostics Mode**

A sequence of diagnostic tests is carried out before starting normal operation.

### **6. Local Mode**

Normal operation of the MFT1501 via front panel switches and buttons. Does not respond to any serial commands except the 'Remote Mode' command.

### **7. Remote Mode**

Responds to commands received via flash/test interface.

MFT1501 can be controlled from a pc.

Pushbuttons and rotary switches are disabled.

Auto-shutdown time is extended to 60mins.

### **8. Other Diodes to aid fault-finding**

Fault\_find – this freezes the conditions (as far as is possible) if an error occurs.

Shutdown\_disable – no autoshutdown except due to dead battery.

Bypass\_eeprom, bypass\_fuse, bypass\_battery – for debugging certain circuit faults.

Tx\_results – all results are transmitted from the MFT1501 via the flash/test interface.

Micro board only – system errors due to the absence of relay/display boards are ignored.

Silent mode – the buzzer is completely disabled.

### **9. No Relay Board Mode**

Sometimes it is convenient to do some fault-finding without the encumbrance of the relay boards. The microcontroller automatically detects if the relay board is not connected, and makes certain changes to the instrument's operation, to ignore irrelevant errors and so on.

Voltage measurement signals are left floating, giving random results, so all voltage readings are set to zero. The warning triangle symbol is shown as a reminder that the readings are forced.

Fuse checks are not carried out, since these rely on feedback from the terminals or the probe.

### **10. No Display Board Mode**

It is unlikely that fault-finding would be done without the display board attached. However, for the sake of completeness, the micro also detects if the display board is not connected. Irrelevant errors are ignored.

The instrument defaults to the voltage range. (This also happens if the rotary switches are not fitted, or else turned to null positions).

## **11. Mode Selection**

There are 4 methods of setting the Operating Mode

### **11.1. By fitting diodes.**

This allows all the following possibilities...

- Calibrate
- Final test
- Debug
- Diagnostics
- Fault find
- Shutdown disable
- Bypass eeprom
- Bypass fuse
- Bypass battery
- Transmit results
- Micro board only
- Silent

Note: If any diodes are fitted, the instrument gives a warning at startup.  
The display shows '<>' alongside the version number.

### **11.2. By remote control**

This allows all the following possibilities...

- Customer (command '0')
- Calibrate (command '1')
- Final test (command '2')
- Final test with result transmission (commands '2', 'x')
- Debug (command '3')

Note: The instrument always reverts to Customer mode and Local mode after being switched OFF.

### **11.3. By the front panel controls**

To access the mode-change screen, turn the rotary switches to an illegal RCD switch position while simultaneously pressing one button from the group of 3 and one button from the group of 2, (e.g. lock button and threshold buttons).

This allows all the following possibilities...

- Customer mode (**CUS**)
- Customer mode with no auto shutdown (**noS**)
- Customer mode silent (**SIL**)
- Calibrate mode (**CAL**)
- Final Test mode (**tES**)
- Final Test mode with result transmission (**trA**)
- Debug mode (**dEb**)

Note: The instrument always reverts to Customer mode after being switched OFF.

To access diagnostics, turn the rotary switches to an illegal RCD switch position while simultaneously pressing all the pushbuttons (backlight button is optional as it is not fitted on the MFT1501).

The message 'diA' shows.

Press a key to enter diagnostics, or turn the rotary switch to abort.

Diagnostics mode is also available by turning the main rotary switch anticlockwise from 1kV Insulation test, but on an assembled instrument the switch stop prevents access.

Note: The instrument always reverts to Customer mode after being switched OFF.

#### **11.4. By the test gear interface**

To select Calibrate mode, short pins 1 & 2 together at startup (CAL\_OR\_TEST & 0VD).

These are the left-most pin of the top row, and the left-most pin of the bottom row, as viewed from the outside of the instrument through the battery compartment.

To select Final Test mode, short pins 1 & 3 together at startup.(CAL\_OR\_TEST & FLASH\_OUT). These are the 2 left-most pins of the bottom row, as viewed through the battery compartment.

To select Diagnostics mode, short pins 3 & 5 together at startup (DIAGS & FLASH\_OUT). These are the pins which are 2<sup>nd</sup> & 3<sup>rd</sup> from the left in the bottom row, as viewed through the battery compartment.

Note: The instrument always reverts to Customer mode after being switched OFF.